

STOP OR YIELD CONTROLLED INTERSECTIONS

EXAMPLE: MAJOR STREET SPEED LIMIT = 25 M.P.H.

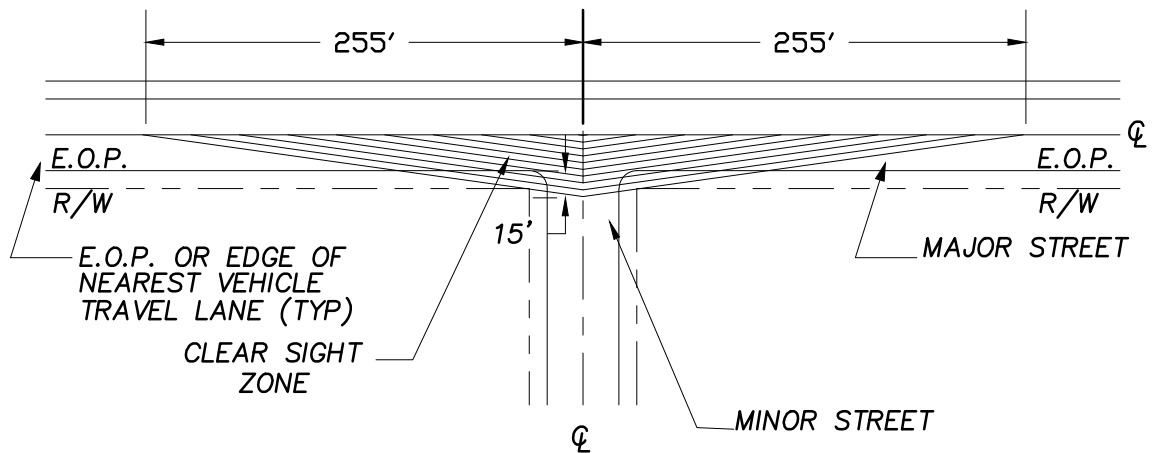

UNCONTROLLED INTERSECTIONS

EXAMPLE: MAJOR STREET SPEED LIMIT = 30 M.P.H.
MINOR STREET SPEED LIMIT = 20 M.P.H.

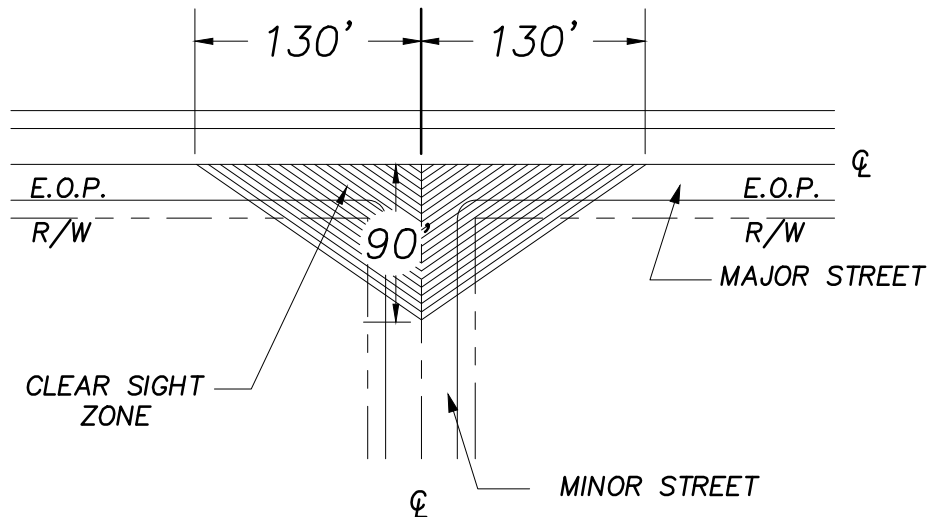

GENERAL NOTES:

1. SEE SECTION 4B.150 OF THE DEVELOPMENT GUIDELINES FOR MORE INFORMATION ON THE VERTICAL CLEARANCE WITHIN THE CLEAR SIGHT ZONE.

APPROVED BY	REVISED DATE	CITY OF OLYMPIA	STD. PLAN NO.
	7/10/06	SIGHT OBSTRUCTION	4-1
CITY ENGINEER			

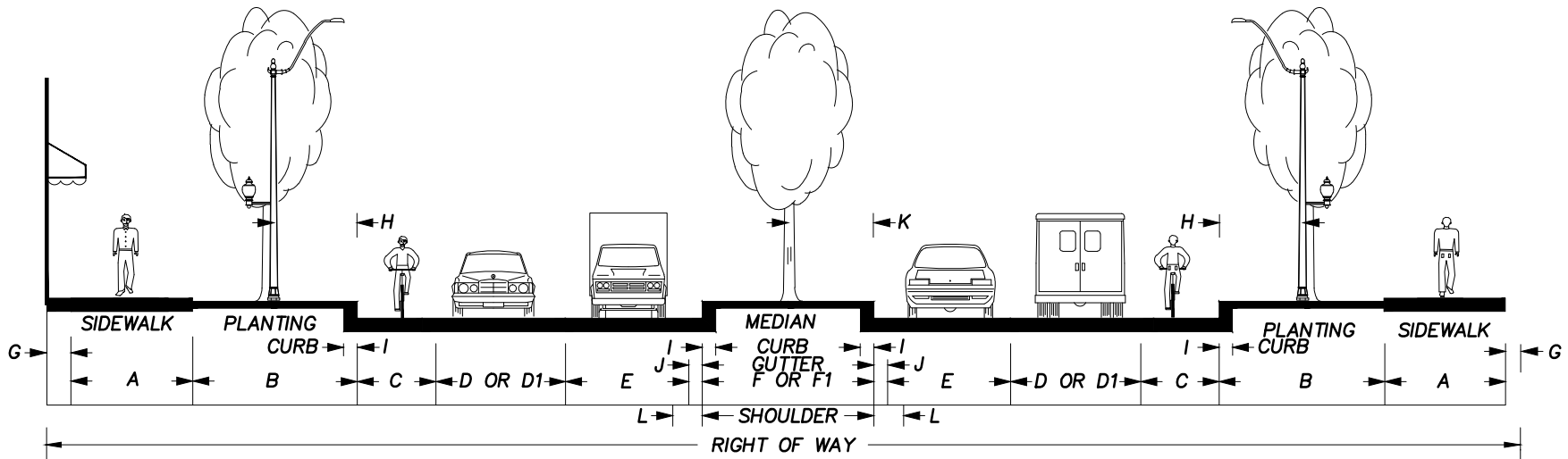

DIMENSIONS = FEET

ARTERIAL BLVD.	SIDEWALK	PLANTING	BIKE LANE	LANE	LANE	LANE	MEDIAN	LEFT TURN LANE	R/W BEHIND SIDEWALK	CURB	GUTTER	SHOULDER	SEE STANDARD PLAN 4-6A FOR MINIMUM STRUCTURAL DESIGN AND STREET CROSS SLOPE DESIGN								
	A	B	*C	D	*D1	E	*F	F1	G	R/W	H	I	J	K	L						
2 LANES	8	10	5	10	0	0	14	0	1	88	5	0.5	1	7	3	SEE MINIMUM STREET DESIGN STANDARDS TABLE FOR ADDITIONAL DESIGN ELEMENTS					
3 LANES	8	10	5	10	0	0	3	11	1	88	5	0.5	1	0	3						
4 LANES	8	10	5	10	14	10	14	0	1 OR 2	104	5	0.5	1	7	0						
5 LANES	8	10	5	10	14	10	3	11	1 OR 2	104	5	0.5	1	0	0						
* SEE DESIGNATED BICYCLE ROUTES FOR DETERMINATION IF C=0 THEN D1 APPLIES, IF C=5 THEN D APPLIES													ADT 14,000-40,000								
* F1 = COMBINATION CENTER LEFT TURN & MEDIAN																					
2 AND 3 LANE BOULEVARD STREET SECTION MUST MAINTAIN 18 FEET FROM CURB FACE TO CURB FACE																					

APPROVED BY	REVISED DATE	CITY OF OLYMPIA ARTERIAL BOULEVARD	STD. PLAN NO.
CITY ENGINEER	12/12/06		4-2A

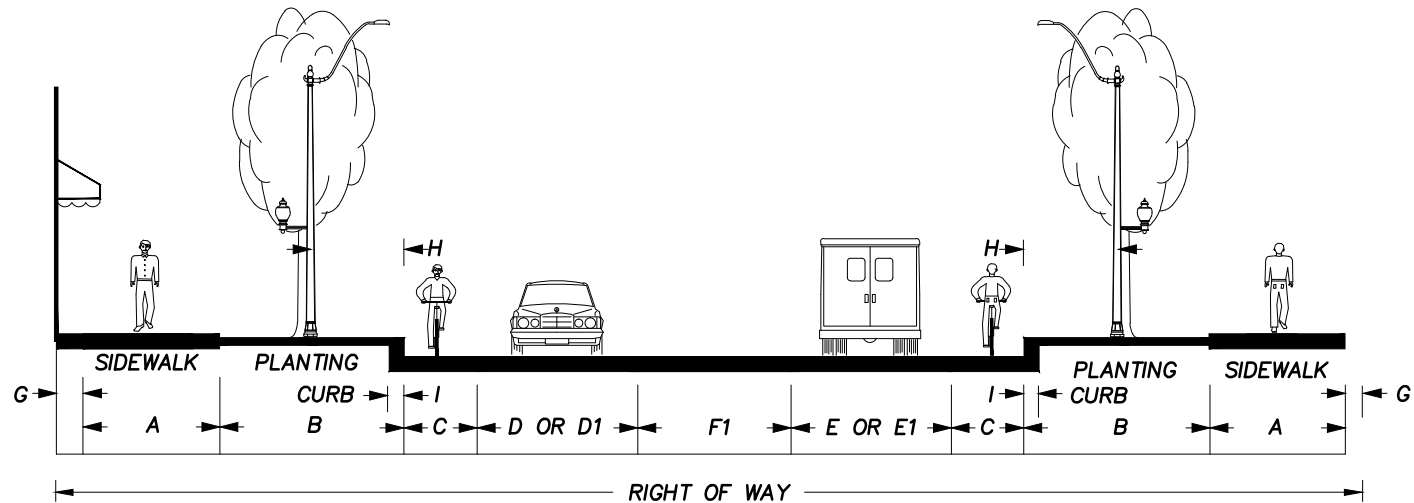

DIMENSIONS = FEET

ARTERIAL	SIDEWALK	PLANTING	BIKE LANE	LANE	LANE	LANE	LEFT TURN LANE	R/W BEHIND SIDEWALK				
	A	B	*C	D	*D1	E	E1	F1	G	R/W	H	I
2 LANES	8	10	5	10	14	10	14	0	1 OR 2	68	5	0.5
3 LANES	8	10	5	10	14	10	14	11	1 OR 2	79	5	0.5
4 LANES	8	10	5	10	14	10	14	0	1 OR 2	88	5	0.5
5 LANES	8	10	5	10	14	10	14	11	1 OR 2	99	5	0.5
* SEE DESIGNATED BICYCLE ROUTES FOR DETERMINATION IF C=0 THEN D1 APPLIES, IF C=5 THEN D APPLIES										SEE STANDARD PLAN 4-6A FOR MINIMUM STRUCTURAL DESIGN AND STREET CROSS SLOPE DESIGN		
										SEE MINIMUM STREET DESIGN STANDARDS TABLE FOR ADDITIONAL DESIGN ELEMENTS		
										ADT 14,000-40,000		

APPROVED BY	REVISED DATE	CITY OF OLYMPIA	STD. PLAN NO.
	12/12/06	ARTERIAL	4-2B
CITY ENGINEER			

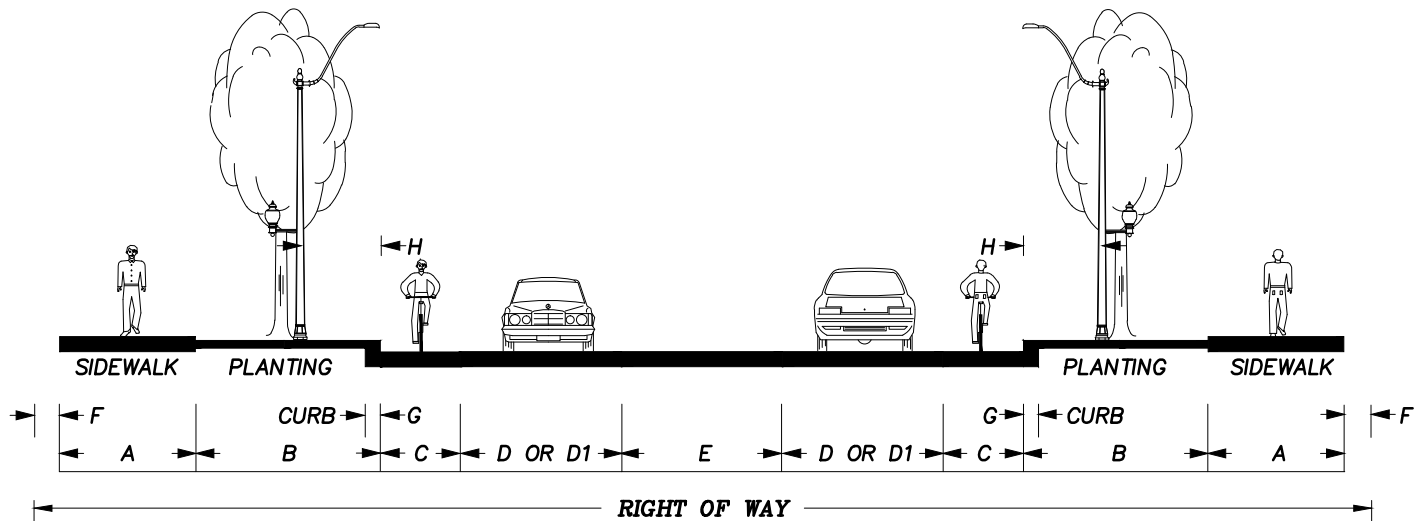

DIMENSIONS = FEET

MAJOR INDUSTRIAL COLL	SIDEWALK	PLANTING	BIKE LANE	LANE	LANE	LEFT TURN LANE	R/W BEHIND SIDEWALK	CURB			SEE STANDARD PLAN 4-6A FOR MINIMUM STRUCTURAL DESIGN AND STREET CROSS SLOPE DESIGN
	A	B	*C	D	*D1	E	F	R/W	G	H	
2 LANES	6	6	5	10	14	0	1 OR 2	56	0.5	3	SEE MINIMUM STREET DESIGN STANDARDS TABLE FOR ADDITIONAL DESIGN ELEMENTS
3 LANES	6	6	5	10	14	11	1 OR 2	67	0.5	3	
4 LANES	6	6	5	10	14	0	1 OR 2	76	0.5	3	
5 LANES	6	6	5	10	14	11	1 OR 2	87	0.5	3	
* SEE DESIGNATED BICYCLE ROUTES FOR DETERMINATION IF C=0 THEN D1 APPLIES, IF C=5 THEN D APPLIES											ADT 3,000-14,000

APPROVED BY	REVISED DATE	CITY OF OLYMPIA MAJOR INDUSTRIAL COLLECTOR	STD. PLAN NO.
CITY ENGINEER	12/12/06		4-2C

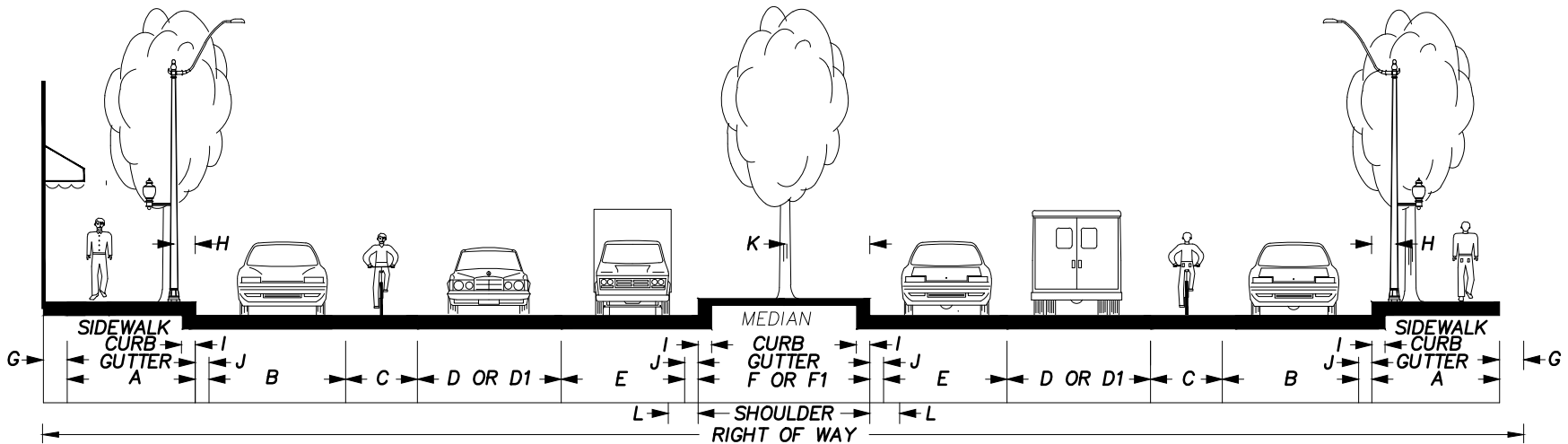

DIMENSIONS = FEET

MAJOR COMM. COLL. BLVD.	SIDEWALK	PARKING	BIKE LANE	LANE	LANE	LANE	MEDIAN	LEFT TURN LANE	R/W BEHIND SIDEWALK	CURB	GUTTER	SHOULDER	SEE STANDARD PLAN 4-6A FOR MINIMUM STRUCTURAL DESIGN AND STREET CROSS SLOPE DESIGN					
	A	B	*C	D	*D1	E	*F	F1	G	R/W	H	I	J	K	L	SEE MINIMUM STREET DESIGN STANDARDS TABLE FOR ADDITIONAL DESIGN ELEMENTS		
2 LANES	10	7	5	10	14	0	10	0	1 OR 2	80	3	0.5	1	7	3	ADT 3,000-14,000		
3 LANES	10	7	5	10	14	0	1	11	1 OR 2	80	3	0.5	1	0	3			
4 LANES	10	7	5	10	14	10	14	0	1 OR 2	104	3	0.5	1	7	0			
* SEE DESIGNATED BICYCLE ROUTES FOR DETERMINATION IF C=0 THEN D1 APPLIES, IF C=5 THEN D APPLIES																		
* F1 = COMBINATION CENTER LEFT TURN & MEDIAN																		

APPROVED BY	REVISED DATE	CITY OF OLYMPIA MAJOR COMMERCIAL COLLECTOR BOULEVARD	STD. PLAN NO.
CITY ENGINEER	12/12/06		4-2D

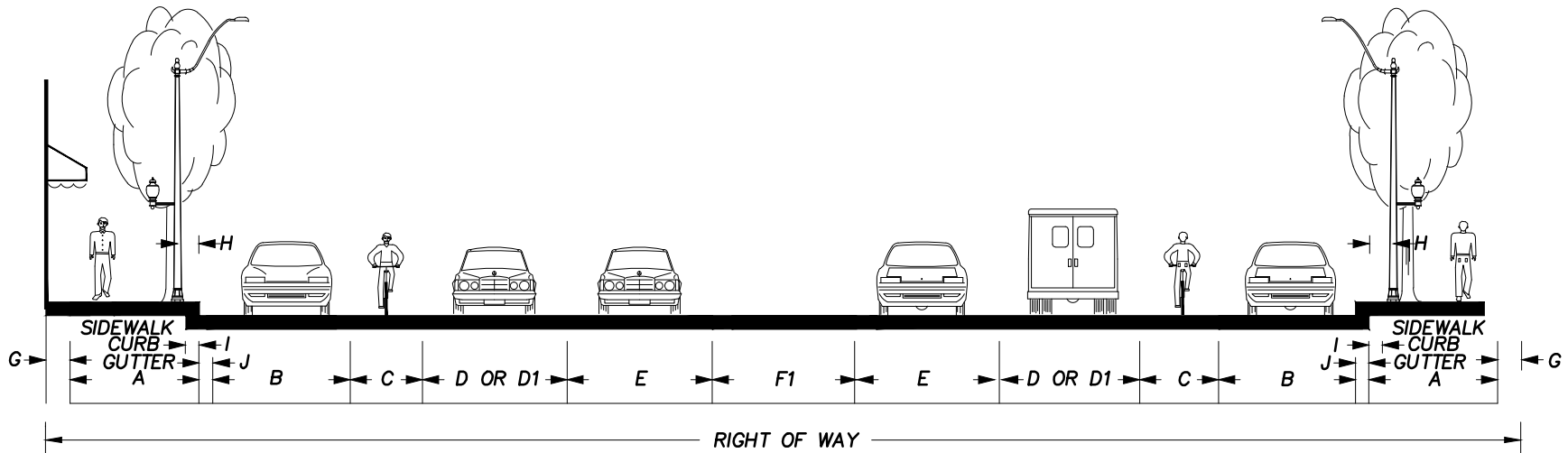

DIMENSIONS = FEET

MAJOR COMM. COLL.	SIDEWALK	PARKING	BIKE LANE	LANE	LANE	LANE	LEFT TURN LANE	R/W BEHIND SIDEWALK	R/W	CURB	GUTTER	
	A	B	*C	D	*D1	E	F1	G	R/W	H	I	J
2 LANES	10	7	5	10	14	0	0	1 OR 2	68	3	0.5	1
3 LANES	10	7	5	10	14	0	11	1 OR 2	79	3	0.5	1
4 LANES	10	7	5	10	14	10	0	1 OR 2	88	3	0.5	1
* SEE DESIGNATED BICYCLE ROUTES FOR DETERMINATION IF C=0 THEN D1 APPLIES, IF C=5 THEN D APPLIES												
												SEE STANDARD PLAN 4-6A FOR MINIMUM STRUCTURAL DESIGN AND STREET CROSS SLOPE DESIGN
												SEE MINIMUM STREET DESIGN STANDARDS TABLE FOR ADDITIONAL DESIGN ELEMENTS
												ADT 3,000-14,000

APPROVED BY	REVISED DATE	CITY OF OLYMPIA MAJOR COMMERCIAL COLLECTOR	STD. PLAN NO.
CITY ENGINEER	12/12/06		4-2E

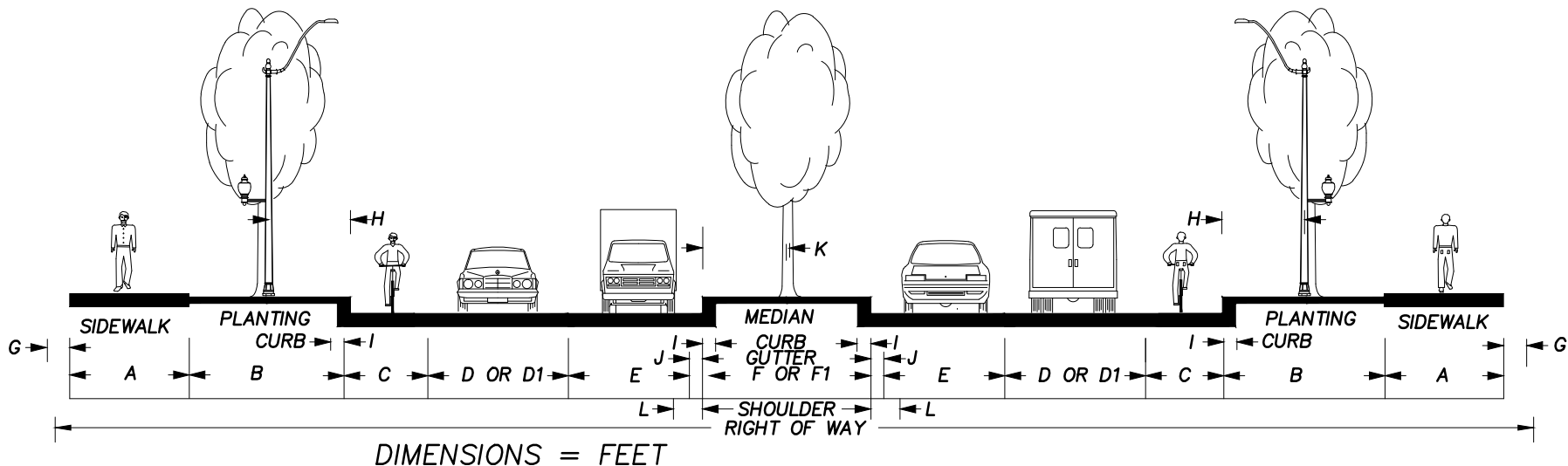

MAJOR COLL. BLVD.	SIDEWALK	PLANTING	BIKE LANE	LANE	LANE	LANE	MEDIAN	LEFT TURN	R/W BEHIND SIDEWALK	CURB	GUTTER	SHOULDER			
	A	B	*C	D	*D1	E	*F	F1	G	R/W	H	I	J	K	L
2 LANES	6	8	5	10	0	0	14	0	1	80	4	0.5	1	7	3
3 LANES	6	8	5	10	0	0	3	11	1	80	4	0.5	1	0	3
4 LANES	6	8	5	10	14	10	14	0	1 OR 2	96	4	0.5	1	7	0
* SEE DESIGNATED BICYCLE ROUTES FOR DETERMINATION IF C=0 THEN D1 APPLIES, IF C=5 THEN D APPLIES * F1 = COMBINATION CENTER LEFT TURN & MEDIAN 2 AND 3 LANE BOULEVARD STREET SECTIONS MUST MAINTAIN 18 FEET FROM CURB FACE TO MEDIAN													SEE STANDARD PLAN 4-6A FOR MINIMUM STRUCTURAL DESIGN AND STREET CROSS SLOPE DESIGN		
													SEE MINIMUM STREET DESIGN STANDARDS TABLE FOR ADDITIONAL DESIGN ELEMENTS		
													ADT 3,000-14,000		

APPROVED BY	REVISED DATE	CITY OF OLYMPIA MAJOR COLLECTOR BOULEVARD	STD. PLAN NO.
CITY ENGINEER	12/12/06		4-2F

HARRISON AVE. TO PARK PROPERTY SOUTH BORDER

WESTSIDE

EASTSIDE

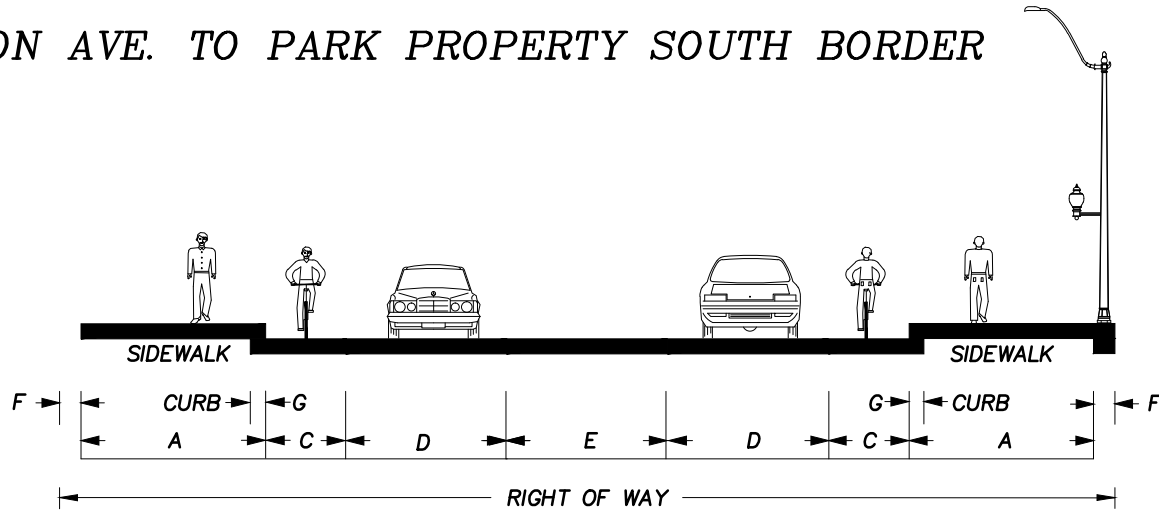

DIMENSIONS = FEET

MAJOR COLL	SIDEWALK	BIKE LANE	LANE	LEFT TURN LANE	R/W BEHIND SIDEWALK		R/W	CURB				
	A	C	D	E	F			G				
2 LANES	6	5	11	0	1 OR 3		48	0.5				
3 LANES	6	5	11	11	1 OR 3		59	0.5				
SEE STANDARD DETAIL 4-6A FOR MINIMUM STRUCTURAL DESIGN AND STREET CROSS SLOPE DESIGN												
SEE MINIMUM STREET DESIGN STANDARDS TABLE FOR ADDITIONAL DESIGN ELEMENTS												
ADT 3,000-14,000												
REFER TO EDDS 4B.085 STREET FRONTAGE IMPROVEMENTS WEST BAY DRIVE.												

APPROVED BY	REVISED DATE	CITY OF OLYMPIA MAJOR COLLECTOR WEST BAY DR.	STD. PLAN NO.
CITY ENGINEER	7/25/07		4-2G1

HARRISON AVE. TO PARK PROPERTY SOUTH BORDER

- *This area is both developed and steep, therefore no widening is recommended. (Widening in this area would make the steep driveways much steeper and possibly unusable.)*
- *To make room for the bicycle lanes, the existing on-street parking would be removed. This change will require re-stripping of the street rather than construction. (The only way to have both bicycle lanes and on-street parking is to widen the street.)*
- *To give residents other options for parking for guests and during inclement weather, pocket parking is recommended for the area just north of where the existing sidewalk ends today. In this area it is possible to get bicycle lanes and parking without building high retaining walls or impacting any existing businesses or residences. Parking on Sherman Street is also available.*
- *The missing sections of sidewalk would be added, as would any necessary repairs to existing sidewalks. If possible, an additional 1-foot of sidewalk would be added on the waterfront side to bring it up to the standard of 6-feet. These changes would likely occur as the utilities were placed underground or the roadbed repaired.*
- *If this area does redevelop, the potential for planter strips should be evaluated with similar criteria as those in the "West Side of the Street - North of Brawne Avenue" section.*

APPROVED BY	REVISED DATE	CITY OF OLYMPIA	STD. PLAN NO.
CITY ENGINEER		MAJOR COLLECTOR WEST BAY DR.	4-2G1A NOTES

PARK PROPERTY SOUTH BORDER TO GARFIELD TRAIL

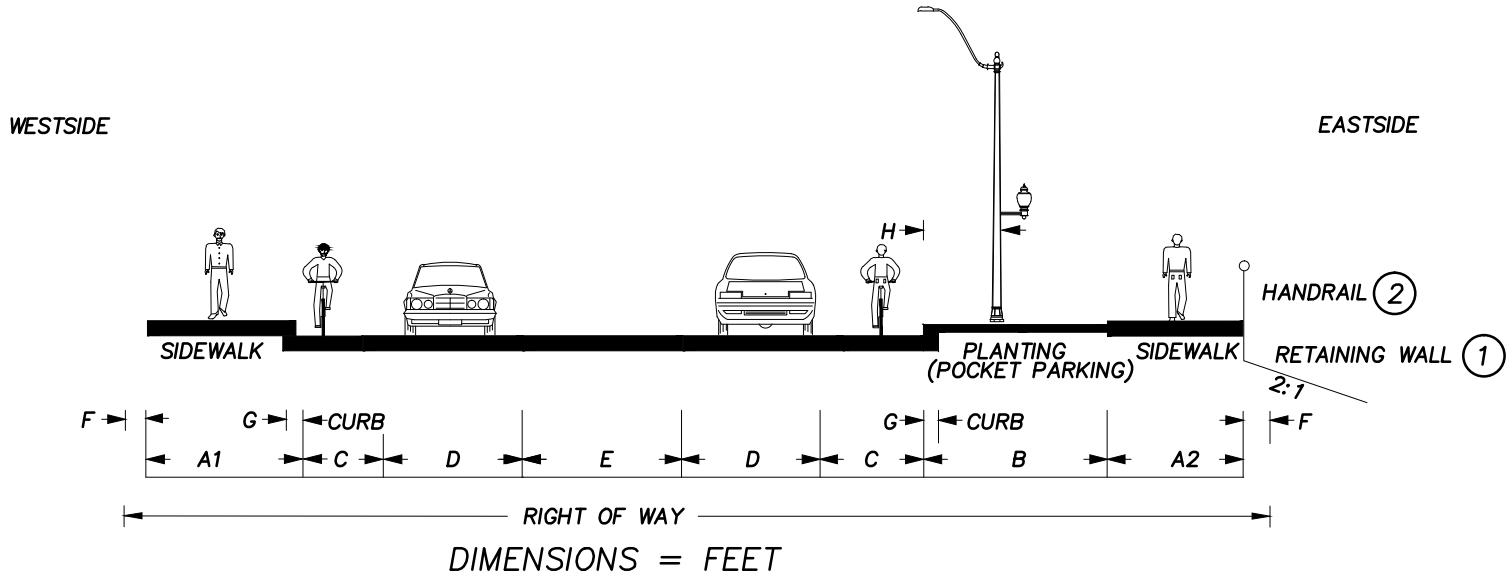

MAJOR COLL	① RETAINING WALLS															SEE STANDARD DETAIL 4-6A FOR MINIMUM STRUCTURAL DESIGN AND STREET CROSS SLOPE DESIGN		
	< 3'		= 3'			> 3'												
	SIDEWALK	PLANTING	SIDEWALK	SIDEWALK	SIDEWALK	BIKE LANE	LANE	LEFT TURN LANE	CURB	R/W BEHIND SIDEWALK							PLANTING (POCKET PARKING)	
	A1	A2	B	H	A2	B	H	A2	B	H	C	D	E	G	F	R/W	B	SEE MINIMUM STREET DESIGN STANDARDS TABLE FOR ADDITIONAL DESIGN ELEMENTS
2 LANES	6	6	8	4	10	0	3	6	0	7.5	5	11	0	0.5	1 OR 3	VARIES	8	
3 LANES	6	6	8	4	10	0	3	6	0	7.5	5	11	11	0.5	1 OR 3	VARIES	8	
② DOWN SLOPES > 2:1 AND RETAINING WALLS ADJACENT TO SIDEWALKS REQUIRE A HANDRAIL																	ADT	
REFER TO EDDS 4B.085 - STREET FRONTAGE IMPROVEMENT WEST BAY DR.																	3,000-14,000	

APPROVED BY	REVISED DATE	CITY OF OLYMPIA MAJOR COLLECTOR WEST BAY DR.	STD. PLAN NO.
CITY ENGINEER	7/26/07		4-2G2

PARK PROPERTY SOUTH BORDER TO GARFIELD TRAIL

East Side of the Street:

- This area is part of the frontage for the proposed West Bay Park.
- Parts of this area have great potential for panoramic views of downtown Olympia; benches are recommended.
- To keep the bicycle network continuous, bicycle lanes will be placed adjacent to the vehicle travel lanes.
- To accommodate the loss of parking in the section of the street to the south, pocket parking will be added if it can be achieved without requiring a retaining wall greater than 3-feet in height. Parking will be broken up or non-continuous using bulb-out type landscaping to keep the street profile small and encourage slower vehicle speeds. It will replace the landscape strip.
- In parts of this section retaining walls will likely be needed. In order to minimize the height of the retaining walls, there are three recommended variations on street improvements recommended, which all relate to the width of the landscape strip. The optimum is to keep the retaining walls 3-feet or less in height because this is the threshold where retaining walls begin to require more structured engineering.
 - a) Flat slope – retaining wall less than 3-feet – 8-foot pocket parking with landscape bulb-outs between the sidewalk and bicycle lane.
 - b) Moderate slope – retaining wall approximately 3-feet – no separate landscape strip but 10-foot sidewalk with street trees.
 - c) Steep slope – retaining wall greater than 3-feet – no landscape or pocket parking strip.
- To provide safety for pedestrians a handrail will be required wherever there is a retaining wall (drop off) next to the sidewalk or if the slope is greater than a 2:1 (horizontal to vertical) grade.

West Side of the Street:

- This area is both developed and steep, therefore no widening is recommended on the West Side of the street. (Widening in this area would make the steep driveways much steeper and possibly unusable.)
- To give residents other options for parking for guests and during inclement weather, pocket parking is recommended for the area just north of where the existing sidewalk ends today. In this area it is possible to get bicycle lanes and parking without building high retaining walls or impacting any existing businesses or residences. Parking on Sherman Street is also available.
- If this area does redevelop, the potential for planter strips should be evaluated with similar criteria as those in the “West Side of the Street – North of Brawne Avenue” section.

Garfield Trail Intersection:

- Install a Pedestrian Crossing Island with a minimum width of 6 feet, provided no significant topographic constraints exist.

APPROVED BY	REVISED DATE	CITY OF OLYMPIA	STD. PLAN NO.
CITY ENGINEER	11/14/2011	MAJOR COLLECTOR	4-2G2A
		WEST BAY DR.	NOTES

GARFIELD TRAIL TO BRAWNE AVE. INTERSECTION

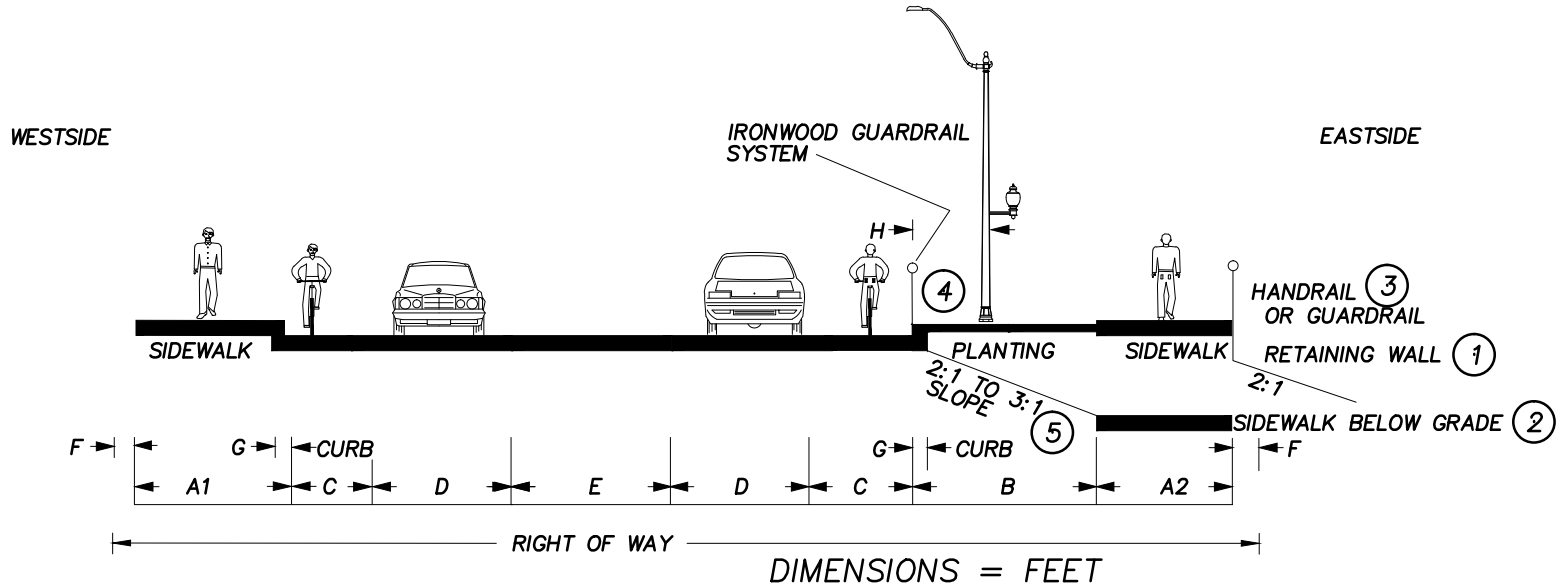

MAJOR COLL	① RETAINING WALLS									② SIDEWALKS BELOW GRADE								SEE STANDARD DETAIL 4-6A FOR MINIMUM STRUCTURAL DESIGN AND STREET CROSS SLOPE DESIGN		
	< 3'			= 3'			> 3'			SIDEWALKS BELOW GRADE			BIKE LANE	LANE	LEFT TURN LANE	CURB	R/W BEHIND SIDEWALK			
	SIDEWALK	PLANTING	SIDEWALK	SIDEWALK	SIDEWALK	SIDEWALK	PLANTING	SIDEWALK	PLANTING	SIDEWALK	SIDEWALK	PLANTING							SIDEWALK	PLANTING
	A1	A2	B	H	A2	B	H	A2	B	H	A2	B	H	C	D	E	G	F	R/W	
2 LANES	6	6	8	4	10	0	3	6	0	7.5	6	8-40	4	5	11	0	0.5	1	OR 3	VARIES
3 LANES	6	6	8	4	10	0	3	6	0	7.5	6	8-40	4	5	11	11	0.5	1	OR 3	VARIES
③ DOWN SLOPES >2:1 AND RETAINING WALLS ADJACENT TO SIDEWALKS REQUIRE A HANDNDRAIL OR GUARDRAIL EVALUATION. ④ DOWN SLOPES >4:1 AND RETAINING WALLS ADJACENT TO STREETS REQUIRE A GUARDRAIL EVAL. ⑤ SIDEWALKS BELOW GRADE WITH PLANTER < 30 FEET WILL HAVE A MAX SLOPE OF 2:1, SIDEWALKS BELOW GRADE WITH PLANTER >= 30 FEET WILL HAVE A MAX SLOPE OF 3:1.																				
ADT 3,000-14,000																				
REFER TO EDDS 4B.085 - STREET FRONTAGE IMPROVEMENT WEST BAY DR.			APPROVED BY			REVISED DATE			CITY OF OLYMPIA MAJOR COLLECTOR WEST BAY DR.						STD. PLAN NO.					
						7/30/07									4-2G3					
			CITY ENGINEER																	

GARFIELD TRAIL TO BRAWNE AVE. INTERSECTION

East Side of the street:

- This area is part of the frontage for the proposed West Bay Park.
- This area has a great potential for panoramic views of downtown Olympia; benches are recommended.
- To keep the bicycle network continuous, the bicycle lanes will remain next to the vehicle travel lanes.
- To preserve flexibility for future park design, sidewalks can be either at street level or down slope slightly.
- Sidewalks will be a minimum of 6-feet wide. Below Grade Option –
- The landscape strip will be a minimum of 8 horizontal 30 or more feet feet if the sidewalk is below grade.
- To provide safety for pedestrians a handrail will be required if there is a retaining wall (drop off) next to the sidewalk, or if the slope is greater than a 2:1 (horizontal to vertical) grade.
- For safety, a guardrail will be required on the backside or curb side of the bicycle lane if the slope is steeper than a 4:1 (horizontal to vertical) grade to the sidewalk.
- If the sidewalk is built at street level retaining walls will likely be needed. In order to minimize the height of the retaining walls, there are three recommended variations on street improvements, which all relate to the width of the landscape strip. The optimum is to keep the retaining walls 3-feet or less in height because this is the threshold where retaining walls begin to require more structured engineering.
 - a) Flat slope – retaining wall less than 3-feet – 8-foot landscape strip between the 6-foot sidewalk and bicycle lane. Pocket parking is not recommended in this section.
 - b) Moderate slope – retaining wall approximately 3-feet – no separate landscape strip but 10-foot sidewalk with landscaping.
 - c) Steep slope – retaining wall greater than 3-feet – no landscape or pocket parking strip.

West Side of the street:

- This area is both developed and steep, therefore no widening is recommended on the West Side of the street. (Widening in this area would make the steep driveways much steeper and possibly unusable.)
- To give residents other options for parking for guests and during inclement weather, pocket parking is recommended for the area just north of where the existing sidewalk ends today. In this area it is possible to get bicycle lanes and parking without building high retaining walls or impacting any existing businesses or residences. Parking on Sherman Street is also available.
- If this area does redevelop, the potential for planter strips should be evaluated with similar criteria as those in the “West Side of the Street – North of Brawne Avenue” section.

Brawne Ave. intersection:

- A left turn lane is recommended for the Brawne Avenue intersection.
- South of the intersection, install a left turn lane to facilitate vehicle flow.
- North of the intersection, install a pedestrian crossing island.

APPROVED BY	REVISED DATE	CITY OF OLYMPIA	STD. PLAN NO.
CITY ENGINEER	11/14/2011	MAJOR COLLECTOR WEST BAY DR.	4-2G3A NOTES

BRAWNE AVE. INTERSECTION TO PARK PROPERTY NORTH BORDER

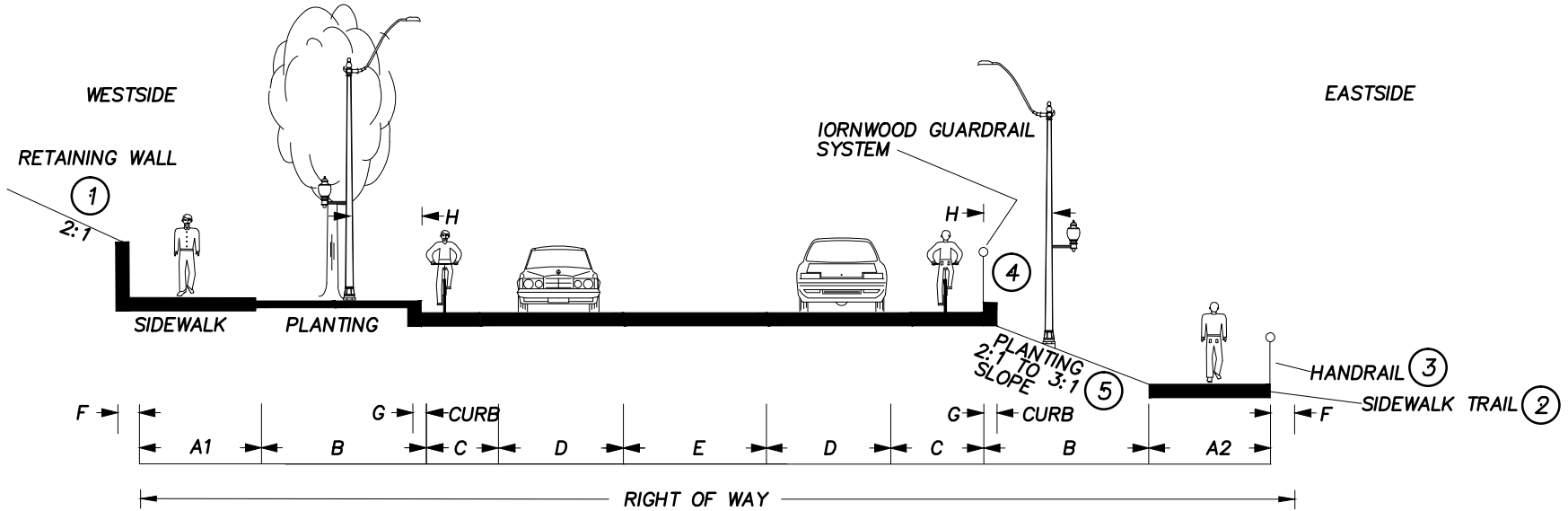

MAJOR COLL	① RETAINING WALLS								② SIDEWALKS BELOW GRADE			DIMENSIONS = FEET					SEE STANDARD DETAIL 4-6A FOR MINIMUM STRUCTURAL DESIGN AND STREET CROSS SLOPE DESIGN
	< 3'		= 3'		> 3'		SIDEWALK	PLANTING	BIKE LANE	LANE	LEFT TURN LANE	CURB	R/W BEHIND SIDEWALK	R/W			
	SIDEWALK	PLANTING	SIDEWALK	SIDEWALK	SIDEWALK	PLANTING									LANE	LANE	
	A1	B H	A1 B H	A1 B H	A2	B H	C	D	E	G	F	R/W					
2 LANES	6	8 4	10 0 3	8 0 7.5	10	8-40 4	5	11	0	0.5	1 OR 3	VARIES					
3 LANES	6	8 4	10 0 3	8 0 7.5	10	8-40 4	5	11	11	0.5	1 OR 3	VARIES					
③ DOWN SLOPES >2:1 AND RETAINING WALLS ADJACENT TO SIDEWALKS REQUIRE A HANDNDRAIL OR GUARDRAIL EVALUATION. ④ DOWN SLOPES >4:1 AND RETAINING WALLS ADJACENT TO STREETS REQUIRE A GUARDRAIL EVAL. ⑤ SIDEWALKS BELOW GRADE WITH PLANTER < 30 FEET WILL HAVE A MAX SLOPE OF 2:1, SIDEWALKS BELOW GRADE WITH PLANTER >= 30 FEET WILL HAVE A MAX SLOPE OF 3:1.													SEE MINIMUM STREET DESIGN STANDARDS TABLE FOR ADDITIONAL DESIGN ELEMENTS				
REFER TO EDDS 4B.085 - STREET FRONTAGE IMPROVEMENT WEST BAY DR.													ADT 3,000-14,000				
							APPROVED BY	REVISED DATE	CITY OF OLYMPIA MAJOR COLLECTOR WEST BAY DR.					STD. PLAN NO.			
							CITY ENGINEER	7/30/07						4-2G4			

BRAWNE AVE. INTERSECTION TO PARK PROPERTY NORTH BORDER

East Side of street:

- To keep the bicycle network continuous, bicycle lanes will remain next to the vehicle travel lanes 34 or more feet
- The proposed park trail and sidewalk will be combined in a 10-foot multi-use facility.
- The landscape strip will be a minimum of 8 horizontal feet. Maximum separation will be no more than 40-feet.
- The railroad right-of-way will be used for combined trail-sidewalk facility wherever practical and safe.
- For safety, pedestrians will be visible from the street.
- For safety, a guardrail will be required on the backside or curb side of the bicycle lane if the slope is steeper than a 4:1 (horizontal to vertical) grade.

West Side of street:

- This section of the street is characterized by steep hillsides alternating with areas of flatter topography. There are sections of existing sidewalks toward the south and other areas with full street improvements, or that will soon have full street improvements, to the north. The flatter parcels are likely to see development or redevelopment in the near future. The steeper areas are less likely to develop or redevelop. Some properties are on the historic register.
- To keep the bicycle network continuous, bicycle lanes will be placed adjacent to the vehicle travel lanes.
- For pedestrian safety, sidewalks (minimum 6-feet) will be added.
- In some areas, retaining walls will likely be needed. In order to minimize the height of the retaining walls, there are three recommended variations on the street improvements which all relate to the width of the landscape strip. The optimum is to keep the retaining walls 3-feet or less in height because this is the threshold where retaining walls begin to require more structured engineering. Smaller retaining walls will also make for a more pleasant pedestrian experience.
 - a) Flat slope – retaining wall less than 3-feet – 6-foot sidewalk with 8-foot landscape strip between the sidewalk and bicycle lane.
 - b) Moderate slope – retaining wall approximately 3-feet – no separate landscape strip but 10-foot sidewalk with street trees.
 - c) Steep slope – retaining wall greater than 3-feet – no landscape strip but an 8-foot sidewalk to provide additional space for pedestrians walking adjacent to the retaining wall.
- These requirements are felt to be the minimum acceptable standards that provide safe vehicle, pedestrian, and bicycle facilities while taking into account the unique requirements of the steep topography in places along the street.
- As areas redevelop, full right-of-way (for full street standards) will be dedicated to the city. This will ensure that the “best engineering solution” be applied to the area, and allow for landscaping behind the sidewalk in areas of steep topography.

Brawne Ave. intersection:

- A left turn lane is recommended for the Brawne Avenue intersection.
- South of the intersection, install a left turn lane to facilitate vehicle flow.
- North of the intersection, install a pedestrian crossing island.

APPROVED BY	REVISED DATE	CITY OF OLYMPIA	STD. PLAN NO.
CITY ENGINEER	11/17/2011	MAJOR COLLECTOR	4-2G4A
		WEST BAY DR.	NOTES

PARK PROPERTY NORTH BORDER TO BASE OF SCHNEIDER HILL

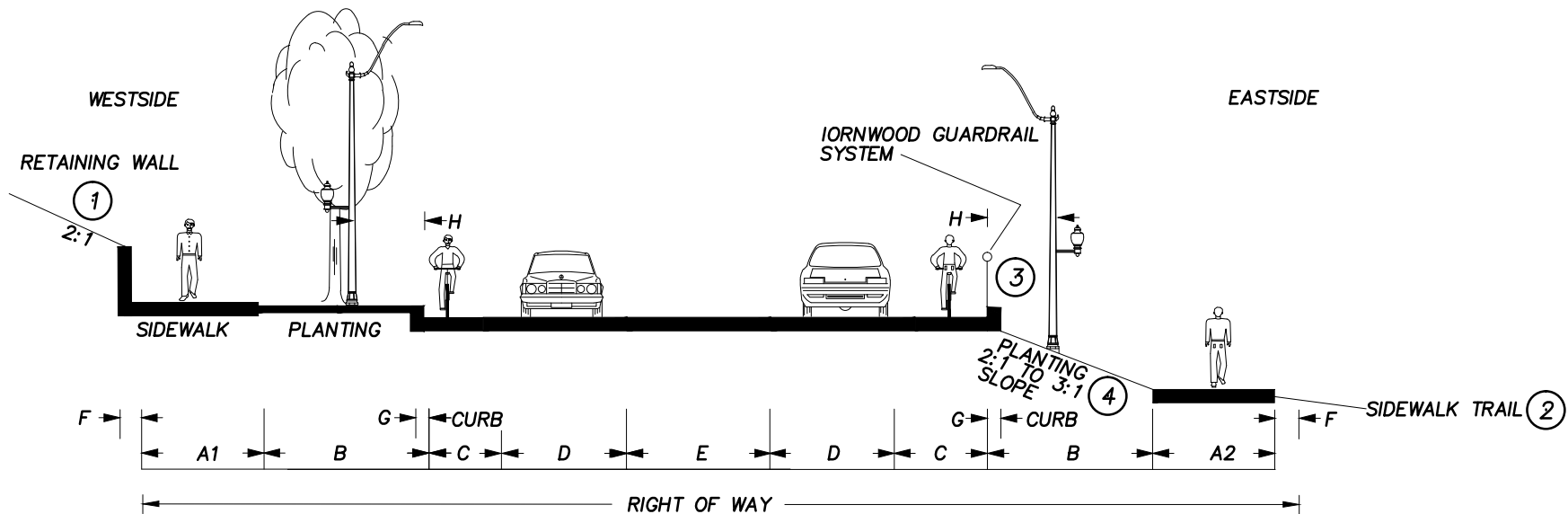

MAJOR COLL	① RETAINING WALLS												② SIDEWALKS BELOW GRADE			DIMENSIONS = FEET					SEE STANDARD DETAIL 4-6A FOR MINIMUM STRUCTURAL DESIGN AND STREET CROSS SLOPE DESIGN
	< 3'			= 3'			> 3'			SIDEWALK	SIDEWALK TRAIL	PLANTING	BIKE LANE	LANE	LEFT TURN LANE	CURB	R/W BEHIND SIDEWALK	R/W			
	SIDEWALK	PLANTING	SIDEWALK	SIDEWALK	SIDEWALK	SIDEWALK	SIDEWALK	SIDEWALK	SIDEWALK TRAIL										PLANTING	C	
	A1	B	H	A1	B	H	A1	B	H	A2	A2	B	H	C	D	E	G	F	R/W		
2 LANES	6	8	4	10	0	3	8	0	7.5	6	10	8-40	4	5	11	0	0.5	1 OR 3	VARIES		
3 LANES	6	8	4	10	0	3	8	0	7.5	6	10	8-40	4	5	11	10	0.5	1 OR 3	VARIES		

③ DOWN SLOPES >4:1 AND RETAINING WALLS ADJACENT TO STREETS REQUIRE A GUARDRAIL EVALUATION.

④ SIDEWALKS BELOW GRADE WITH PLANTER < 30 FEET WILL HAVE A MAX SLOPE OF 2:1, SIDEWALKS BELOW GRADE WITH PLANTER >= 30 FEET WILL HAVE A MAX SLOPE OF 3:1. REFER TO EDDS 4B.085 - STREET FRONTAGE IMPROVEMENT WEST BAY DR.

SEE STANDARD DETAIL 4-6A FOR MINIMUM STRUCTURAL DESIGN AND STREET CROSS SLOPE DESIGN

SEE MINIMUM STREET DESIGN STANDARDS TABLE FOR ADDITIONAL DESIGN ELEMENTS

ADT
3,000-14,000

APPROVED BY	REVISED DATE	CITY OF OLYMPIA MAJOR COLLECTOR WEST BAY DR.	STD. PLAN NO.
CITY ENGINEER	7/30/07		4-2G5

PARK PROPERTY NORTH BORDER TO BASE OF SCHNEIDER HILL

West Side of the Street

- This section of the street is characterized by steep hillsides alternating with areas of flatter topography. There are sections of existing sidewalks toward the south and other areas with full street improvements, or that will soon have full street improvements, to the north. The flatter parcels are likely to see development or redevelopment in the near future. The steeper areas are less likely to develop or redevelop. Some properties are on the historic register.
- To keep the bicycle network continuous, bicycle lanes will be placed adjacent to the vehicle travel lanes.
- For pedestrian safety, sidewalks (minimum 6-feet) will be added.
- In some areas, retaining walls will likely be needed. In order to minimize the height of the retaining walls, there are three recommended variations on the street improvements which all relate to the width of the landscape strip. The optimum is to keep the retaining walls 3-feet or less in height because this is the threshold where retaining walls begin to require more structured engineering. Smaller retaining walls will also make for a more pleasant pedestrian experience.
 - a) Flat slope – retaining wall less than 3-feet – 6-foot sidewalk with 8-foot landscape strip between the sidewalk and bicycle lane.
 - b) Moderate slope – retaining wall approximately 3-feet – no separate landscape strip but 10-foot sidewalk with street trees.
 - c) Steep slope – retaining wall greater than 3-feet – no landscape strip but an 8-foot sidewalk to provide additional space for pedestrians walking adjacent to the retaining wall.
- These requirements are felt to be the minimum acceptable standards that provide safe vehicle, pedestrian, and bicycle facilities while taking into account the unique requirements of the steep topography in places along the street.
- As areas redevelop, full right-of-way (for full street standards) will be dedicated to the city. This will ensure that the “best engineering solution” be applied to the area, and allow for landscaping behind the sidewalk in areas of steep topography.

Woodard Avenue Intersection:

- Install a Pedestrian Crossing Island (minimum 6 foot width).

APPROVED BY	REVISED DATE	CITY OF OLYMPIA	STD. PLAN NO.
CITY ENGINEER	11/14/2011	MAJOR COLLECTOR WEST BAY DR.	4-2G5A NOTES

PARK PROPERTY NORTH BORDER TO BASE OF SCHNEIDER HILL

East Side of street

- This area includes current or former industrial properties. The properties that are vacant now are expected to redevelop in the near term. The remaining industrial site (Brown–Minneapolis Tank) will likely remain industrial in the near term.
- To keep the bicycle network continuous, the bicycle lanes will remain next to the vehicle travel lanes.
- Option A: The long–term plan is for the West Bay Multi–Use Trail to follow the shoreline. If the trail is built at the same time or prior to street improvements, then:
 - A 6–foot sidewalk below street grade will complete the pedestrian facilities. The sidewalk will come to grade at driveways and any intersections.
 - The landscape strip is a minimum of 8 horizontal feet. Placing the sidewalk below grade will minimize the need for retaining walls but may require additional right–of–way. The sidewalk may be placed at grade if preferred.
 - For safety, pedestrians will be visible from the street.
 - For safety, a guardrail will be required if the slope is steeper than a 4:1 (horizontal to vertical) grade.
- Option B: Across from the Brown–Minneapolis Tank property the long–term plan is to have the trail along the shoreline. If street improvements are made while the site remains in industrial use, it is recommended that the trail be combined with the sidewalk into a 10–foot multi–use facility. All other conditions from Option A will apply.

APPROVED BY	REVISED DATE	CITY OF OLYMPIA	STD. PLAN NO.
CITY ENGINEER	7/30/07	MAJOR COLLECTOR WEST BAY DR.	4–2G5B NOTES

SCHNEIDER HILL

WESTSIDE

EASTSIDE

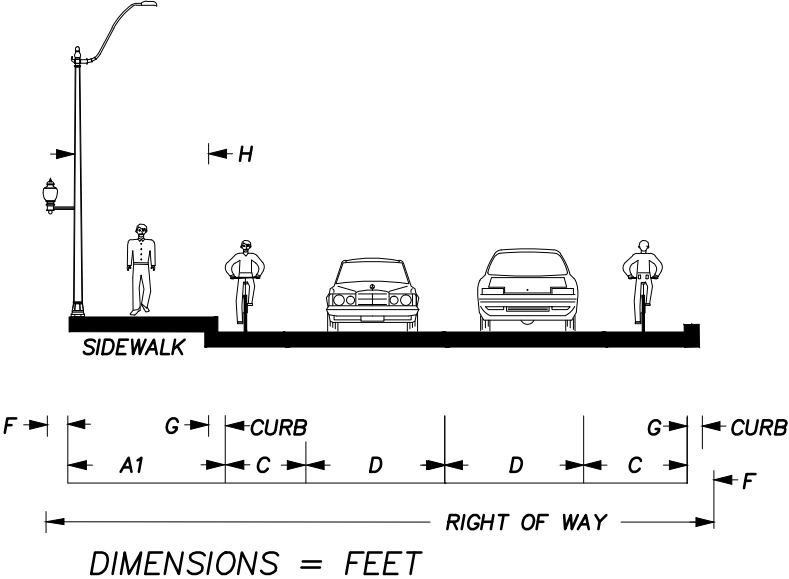

MAJOR COLL	SIDEWALK	BIKE LANE	LANE	R/W BEHIND SIDEWALK	CURB			
	A	*C	D	F	R/W	G	H	
2 LANES	6	6	10	1	40.5	0.5	7.5	

SEE STANDARD DETAIL 4-6A FOR MINIMUM STRUCTURAL DESIGN AND STREET CROSS SLOPE DESIGN

SEE MINIMUM STREET DESIGN STANDARDS TABLE FOR ADDITIONAL DESIGN ELEMENTS

ADT
3,000-14,000

REFER TO EDDS 4B.085 - STREET FRONTAGE IMPROVEMENT WEST BAY DR.

APPROVED BY	REVISED DATE	CITY OF OLYMPIA	STD. PLAN NO.
CITY ENGINEER	7/30/07	MAJOR COLLECTOR	4-2G6
		WEST BAY DR.	

SCHNEIDER HILL

Schneider Hill

- This is the steepest section of street in the study area. Any street widening will require engineered retaining walls. The existing sidewalk is 5-foot wide, and is adjacent to a high retaining wall.
- Due to the difficulties in street widening, no planter strips will be required.
- To provide for pedestrian safety, a wider (8-foot) sidewalk on the west side of the street is recommended.
- Bicycle lanes are in the Olympia Comprehensive Plan for Schneider Hill to link to the Westside neighborhoods. The City street standards define bicycle lanes in both directions therefore bicycle lanes on both sides of the street are recommended for this section.

APPROVED BY	REVISED DATE	CITY OF OLYMPIA	STD. PLAN NO.
	7/30/07	MAJOR COLLECTOR	4-2G6A
CITY ENGINEER		WEST BAY DR.	NOTES

SCHNEIDER HILL TO MARINA

WESTSIDE

EASTSIDE

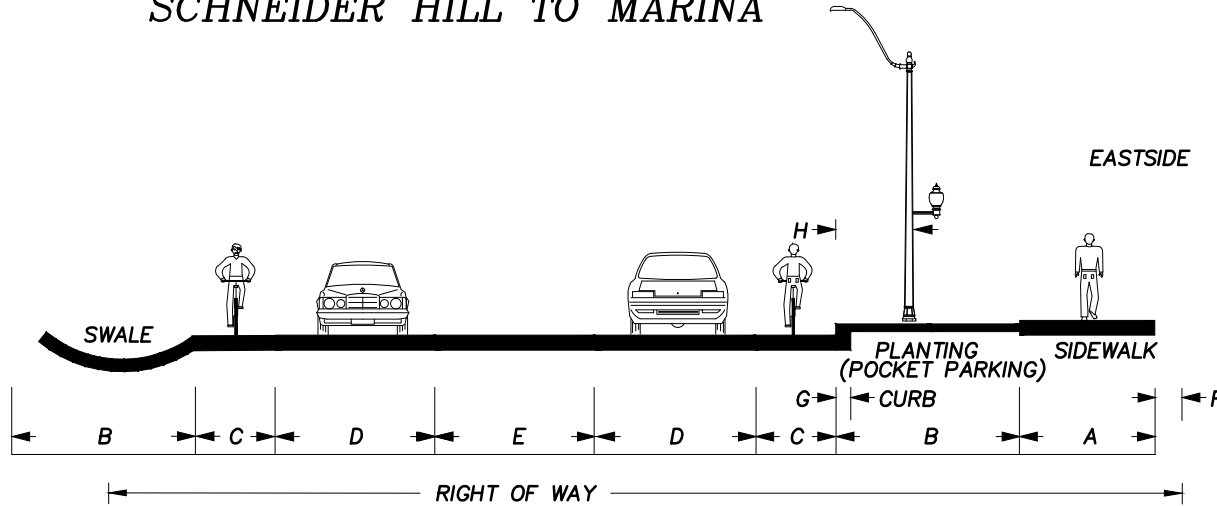

DIMENSIONS = FEET

MAJOR COLL	SIDEWALK	PLANTING (POCKET PARKING)	BIKE LANE	LANE	LEFT TURN LANE	R/W BEHIND SIDEWALK	CURB				SEE STANDARD DETAIL 4-6A FOR MINIMUM STRUCTURAL DESIGN AND STREET CROSS SLOPE DESIGN
	A	B	C	D	E	F	R/W	G	H		
2 LANES	10	8	5	11	0	1	59	0.5	4		SEE MINIMUM STREET DESIGN STANDARDS TABLE FOR ADDITIONAL DESIGN ELEMENTS
3 LANES	10	8	5	11	11	1	70	0.5	4		
ADT 3,000-14,000											
REFER TO EDDS 4B.085 - STREET FRONTAGE IMPROVEMENT WEST BAY DR.											

APPROVED BY	REVISED DATE	CITY OF OLYMPIA	STD. PLAN NO.
CITY ENGINEER	7/26/07	MAJOR COLLECTOR WEST BAY DR.	4-2G7

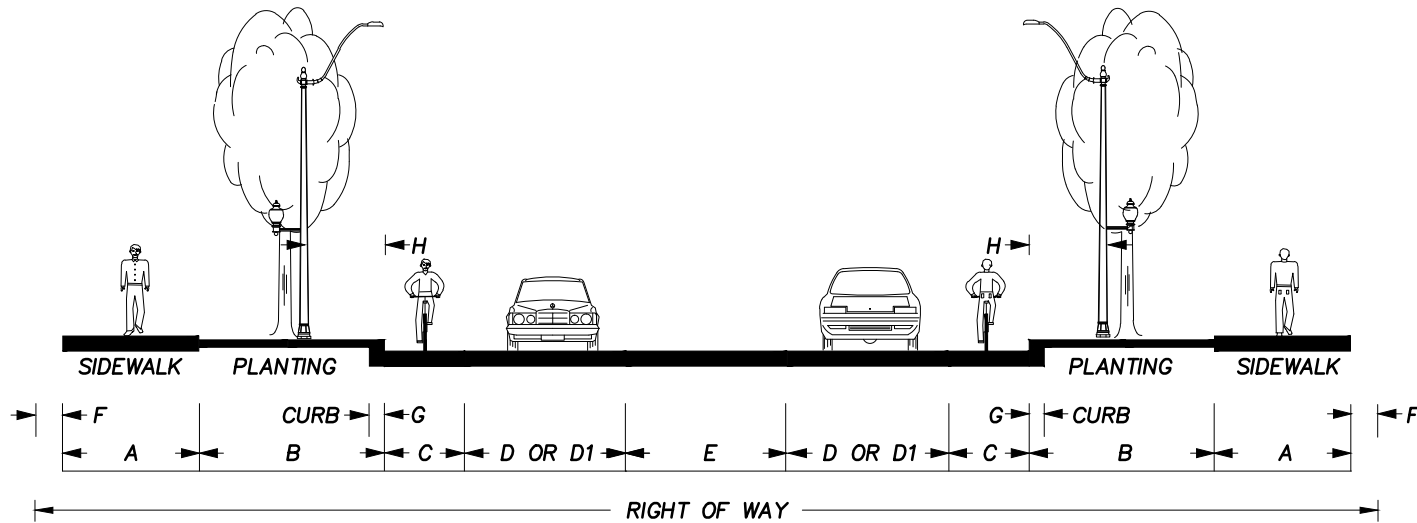

DIMENSIONS = FEET

MAJOR COLL	SIDEWALK	PLANTING	BIKE LANE	LANE	LANE	LEFT TURN LANE	R/W BEHIND SIDEWALK	CURB	SEE STANDARD DETAIL 4-6A FOR MINIMUM STRUCTURAL DESIGN AND STREET CROSS SLOPE DESIGN				
	A	B	*C	D	*D1	E	F	R/W	G	H			
2 LANES	6	8	5	10	14	0	1 OR 2	60	0.5	4			
3 LANES	6	8	5	10	14	11	1 OR 2	71	0.5	4			
4 LANES	6	8	5	10	14	0	1 OR 2	80	0.5	4			
* SEE DESIGNATED BICYCLE ROUTES FOR DETERMINATION IF C=0 THEN D1 APPLIES, IF C=5 THEN D APPLIES												SEE MINIMUM STREET DESIGN STANDARDS TABLE FOR ADDITIONAL DESIGN ELEMENTS	
												ADT 3,000-14,000	

APPROVED BY	REVISED DATE	CITY OF OLYMPIA	STD. PLAN NO.
	12/12/06	MAJOR COLLECTOR	4-2G
CITY ENGINEER			

SCHNEIDER HILL TO MARINA

The Base of Schneider Hill to the Marina

- *This section of West Bay Drive is classified as a "Major Commercial Collector" and has slightly different standards than the other sections. There is a steep, wet hill on the west side of this street. On the waterfront side the topography is flatter, but the railroad and railroad right-of-way run through the street.*
- *To provide a continuous bicycle network out to the Marina, bicycle lanes will be placed next to the vehicle travel lanes.*
- *As development is only expected to occur on the waterfront side of this street, onstreet pocket parking with landscaping bulb-outs, and a 10-foot sidewalk are recommended for this side only.*
- *The 10-foot sidewalk would link into the proposed West Bay Trail system to provide a continuous, wide, pedestrian facility all the way from the Marina to Downtown.*
- *Any additional widening or frontage improvements on the west side of the street are not recommended due to the steep, wet slopes.*

<i>APPROVED BY</i>	<i>REVISED DATE</i>	CITY OF OLYMPIA	<i>STD. PLAN NO.</i>
<i>CITY ENGINEER</i>	7/26/07	MAJOR COLLECTOR WEST BAY DR.	4-2G7A NOTES

BOULEVARD ROAD MEDIANS

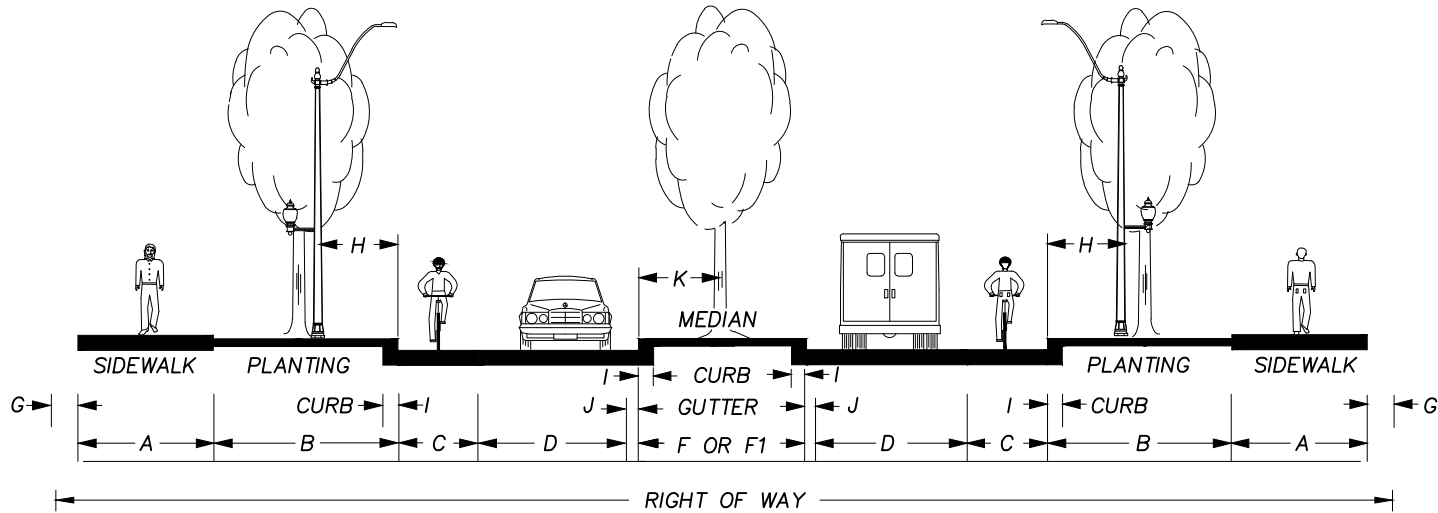

DIMENSIONS = FEET

MAJOR COLLECTOR BLVD	SIDEWALK	PLANTING	BIKE LANE	LANE	MEDIAN	LEFT TURN LANE	R/W BEHIND SIDEWALK	CURB	GUTTER							
	A	B	C	D	*F	F1	G	R/W	H	I	J	K				
2 LANES	6	8	5	10	9	0	1	71	4	0.5	1	4.5	SEE STANDARD DETAIL 4-6A FOR MINIMUM STRUCTURAL DESIGN AND STREET CROSS SLOPE DESIGN SEE MINIMUM STREET DESIGN STANDARDS TABLE FOR ADDITIONAL DESIGN ELEMENTS ADT 3,000-14,000			
3 LANES	6	4.5	5	10	6	10	1	71	2	0.5	1	0				
* F1= COMBINATION CENTER LEFT TURN & MEDIAN 2 AND 3 LANE MEDIAN SECTIONS CAN NOT EXTEND GREATER THAN 350 FEET. REFER TO EDDS 4B.090 - STREET FRONTAGE IMPROVEMENT BOULEVARD RD.																

APPROVED BY	REVISED DATE	CITY OF OLYMPIA MAJOR COLLECTOR BOULEVARD RD.	STD. PLAN NO.
CITY ENGINEER	5/31/2011		4-2G8

PLUM STREET TO CHERRY STREET

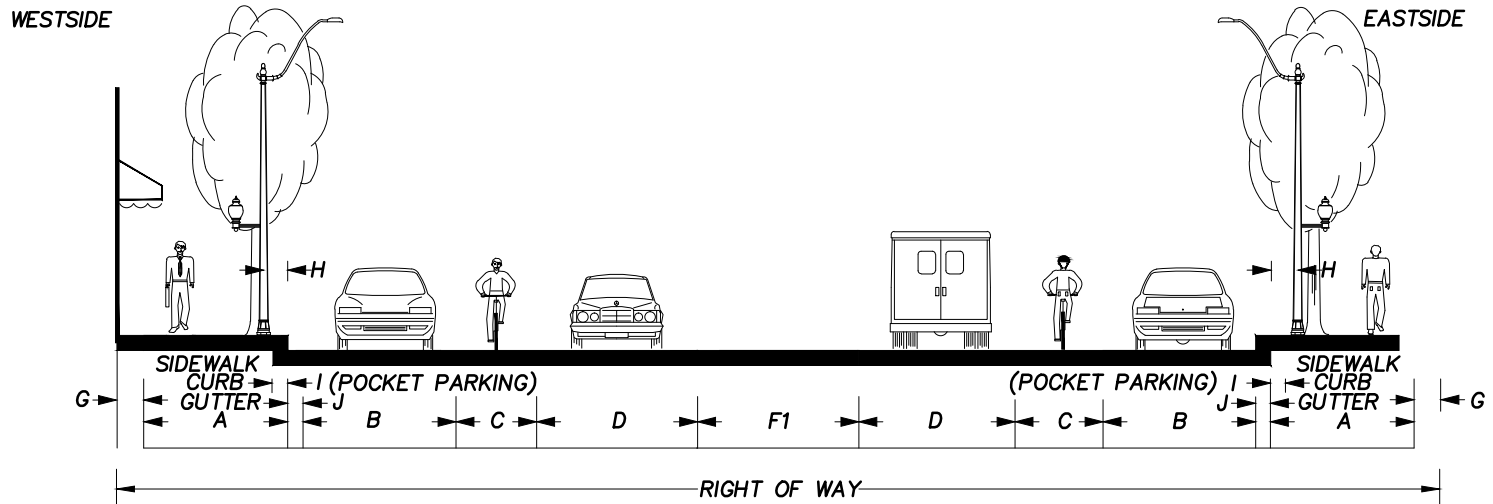

DIMENSIONS = FEET

MAJOR COMM. COLL.	SIDEWALK (POCKET PARKING)	BIKE LANE	LANE	LANE	LEFT TURN LANE	R/W BEHIND SIDEWALK	CURB	GUTTER	SEE STANDARD PLAN 4-6A FOR MINIMUM STRUCTURAL DESIGN AND STREET CROSS SLOPE DESIGN			
	A	B	C	D	E	F1	G	R/W	H	I	J	
2 LANES	17	7	5	10	0	0	1 OR 2	80	3	0.5	1	SEE MINIMUM STREET DESIGN STANDARDS TABLE FOR ADDITIONAL DESIGN ELEMENTS
3 LANES	11.5	7	5	10	0	11	1 OR 2	80	3	0.5	1	
* BULB-OUTS WILL BE PROVIDED MID-BLOCK AND ON ALL CORNERS REFER TO EDDS 4B.095-STREET FRONTAGE IMPROVEMENT EAST DOWNTOWN									ADT 3,000-14,000			

APPROVED BY	REVISED DATE	CITY OF OLYMPIA	STD. PLAN NO.
CITY ENGINEER	7/25/07	MAJOR COMMERCIAL COLLECTOR LEGION WAY	4-2G10

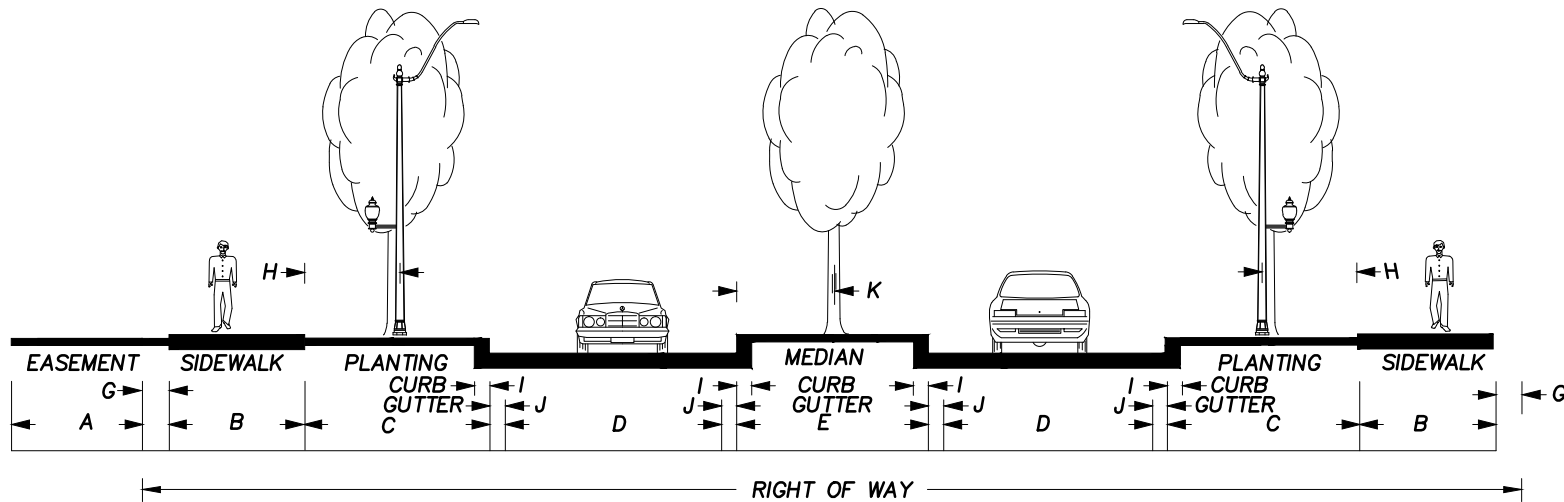

DIMENSIONS = FEET

NEIGHBORHOOD COLL. BLVD.	EASEMENT	SIDEWALK	PLANTING	LANE	MEDIAN	R/W BEHIND SIDEWALK	R/W	H	CURB I	GUTTER J	K	
	A	B	C	D	E	G						
2 LANES	10	5	8	16	10	1	74	4	0.5	1	5	
A= PRIVATE UTILITY EASEMENT												
												SEE STANDARD PLAN 4-6A FOR MINIMUM STRUCTURAL DESIGN AND STREET CROSS SLOPE DESIGN
												SEE MINIMUM STREET DESIGN STANDARDS TABLE FOR ADDITIONAL DESIGN ELEMENTS
												ADT 500-3,000

BOULEVARD STREET SECTIONS MUST MAINTAIN 18 FEET FROM CURB FACE TO MEDIAN

APPROVED BY	REVISED DATE	CITY OF OLYMPIA NEIGHBORHOOD COLLECTOR BOULEVARD	STD. PLAN NO.
CITY ENGINEER	12/12/06		4-2H

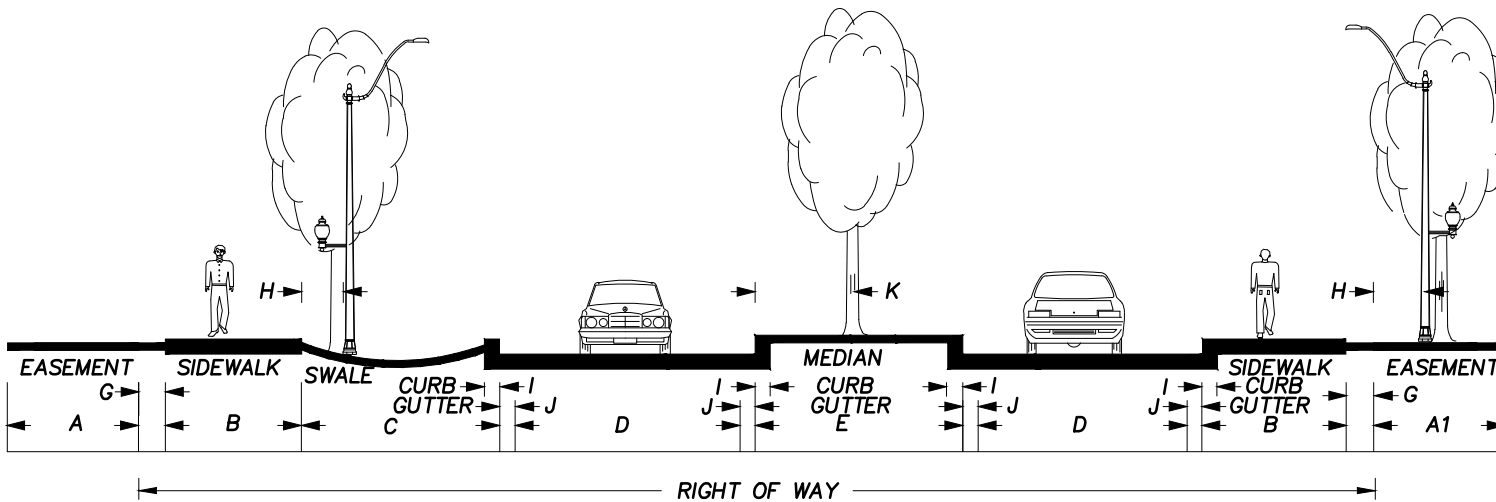

DIMENSIONS = FEET

NEIGHBORHOOD COLL. BLVD. W/SWALE	EASEMENT	EASEMENT	SIDEWALK	SWALE	LANE	MEDIAN	R/W BEHIND SIDEWALK	R/W	H	CURB	GUTTER	K
	A	A1	B	C	D	E	G					
2 LANES	10	6	5	12	16	10	1	70	3	0.5	1	5
SEE STANDARD PLAN 4-6A FOR MINIMUM STRUCTURAL DESIGN AND STREET CROSS SLOPE DESIGN												
SEE MINIMUM STREET DESIGN STANDARDS TABLE FOR ADDITIONAL DESIGN ELEMENTS												
ADT 500-3,000												
A= PRIVATE UTILITY EASEMENT												
A1= TREE & UTILITY EASEMENT DEDICATED TO CITY OF OLYMPIA												
C= SWALE PERMITTED WITH CITY OF OLYMPIA APPROVAL ONLY												
BOULEVARD STREET SECTIONS MUST MAINTAIN 18 FEET FROM CURB FACE TO MEDIAN												

APPROVED BY	REVISED DATE	CITY OF OLYMPIA NEIGHBORHOOD COLLECTOR BOULEVARD WITH SWALE	STD. PLAN NO.
CITY ENGINEER	12/12/06		4-2H1

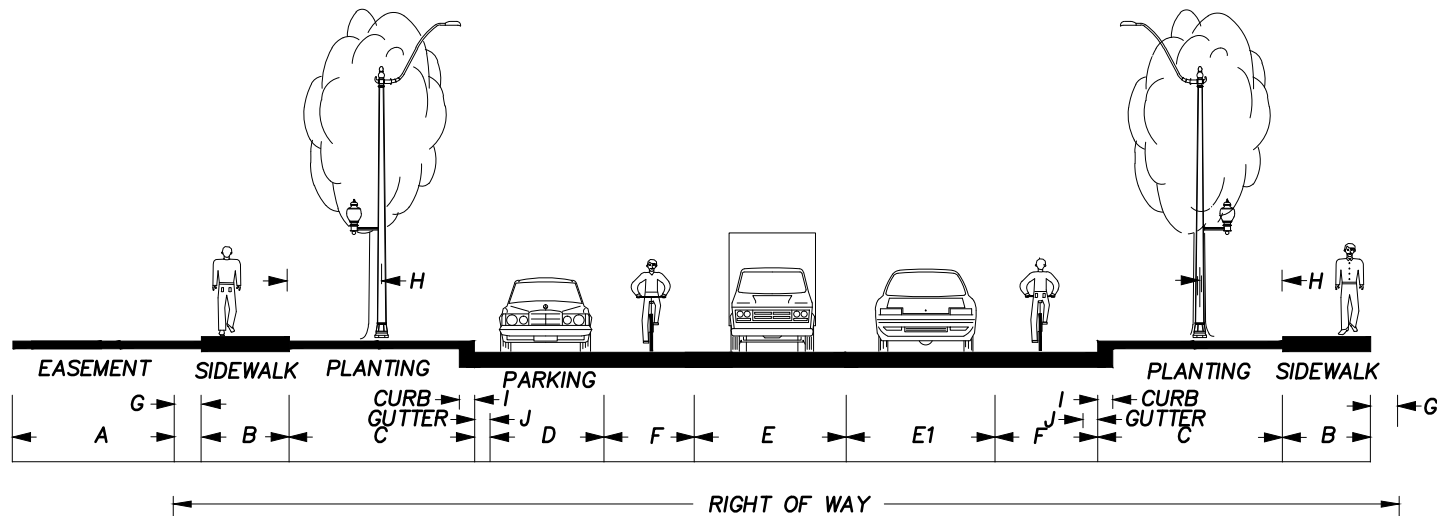

DIMENSIONS = FEET

NEIGHBORHOOD COLLECTOR	EASEMENT	SIDEWALK	PLANTING	PARKING	LANE	LANE	BIKE LANE	R/W BEHIND SIDEWALK			CURB	GUTTER*	SEE STANDARD PLAN 4-6A FOR MINIMUM STRUCTURAL DESIGN AND STREET CROSS SLOPE DESIGN SEE MINIMUM STREET DESIGN STANDARDS TABLE FOR ADDITIONAL DESIGN ELEMENTS ADT 500-3,000
	A	B	C	D	E	E1	F	G	R/W	H	I	J	
2 LANES	10	5	8	6	10	9	0	1	55	4	0.5	1	
2 LANES CLASS II*	10	5	8	6	10	10	5	1	65	4	0.5	1	
2 LANES CLASS III*	10	5	8	6	14	14	0	2	65	4	0.5	1	
A= PRIVATE UTILITY EASEMENT													
*GUTTER NOT ALLOWED NEXT TO BIKE FACILITY													

APPROVED BY	REVISED DATE	CITY OF OLYMPIA NEIGHBORHOOD COLLECTOR STREET	STD. PLAN NO.
CITY ENGINEER	12/12/06		4-21

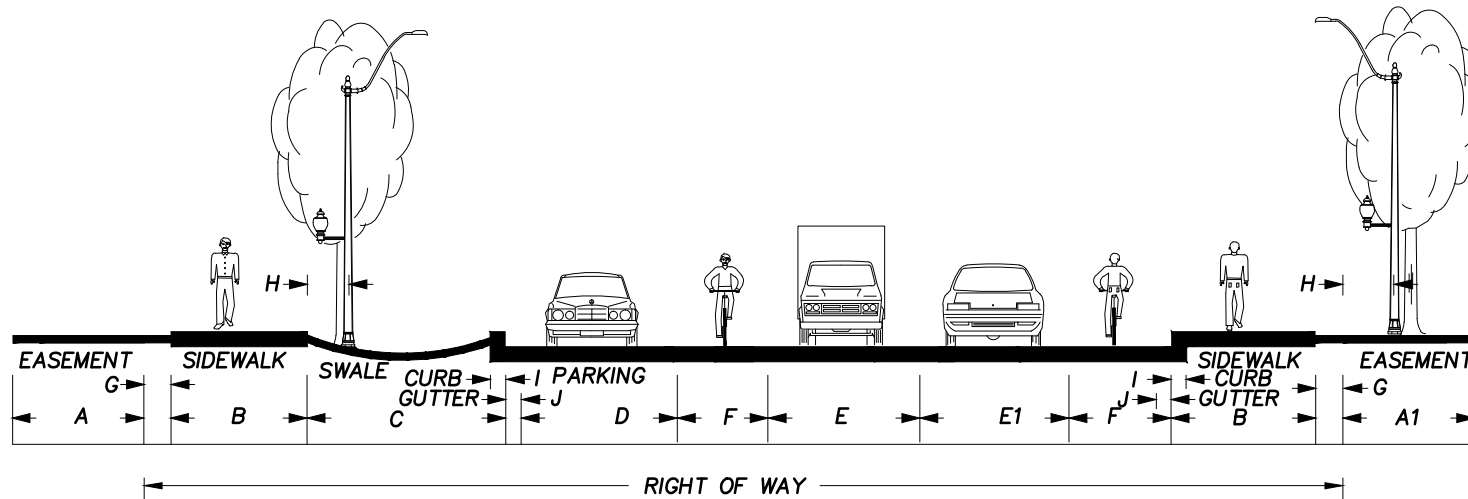

DIMENSIONS = FEET

NEIGHBORHOOD COLL. W/SWALE	EASEMENT		SIDEWALK	SWALE	PARKING	LANE	LANE	BIKE LANE	R/W BEHIND SIDEWALK	R/W	H	CURB	GUTTER*	SEE STANDARD PLAN 4-6A FOR MINIMUM STRUCTURAL DESIGN AND STREET CROSS SLOPE DESIGN SEE MINIMUM STREET DESIGN STANDARDS TABLE FOR ADDITIONAL DESIGN ELEMENTS ADT 500-3,000
	A	A1	B	C	D	E	E1	F	G					
2 LANES	10	6	5	12	6	10	9	0	1	51	3	0.5	1	
2 LANES CLASS II*	10	6	5	12	6	10	10	5	1	61	3	0.5	1	
2 LANES CLASS III*	10	6	5	12	6	14	14	0	2	61	3	0.5	1	
A= PRIVATE UTILITY EASEMENT A1= TREE & UTILITY EASEMENT DEDICATED TO CITY OF OLYMPIA C= SWALE PERMITTED WITH CITY OF OLYMPIA APPROVAL ONLY *GUTTER NOT ALLOWED NEXT TO BIKE FACILITY														

APPROVED BY	REVISED DATE	CITY OF OLYMPIA NEIGHBORHOOD COLLECTOR WITH SWALE	STD. PLAN NO.
CITY ENGINEER	12/12/06		4-211

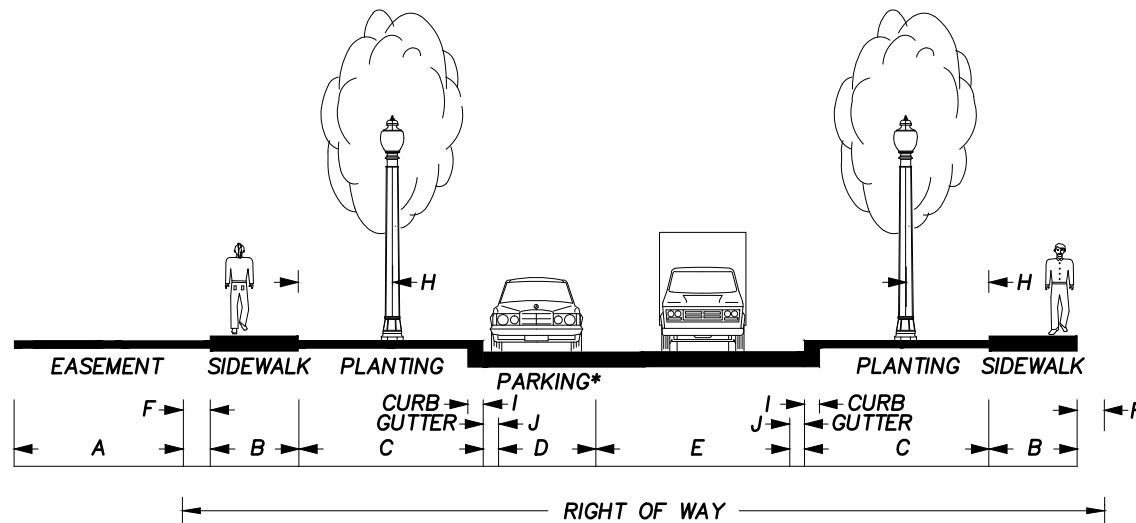

DIMENSIONS = FEET

LOCAL ACCESS STREET	EASEMENT	SIDEWALK	PLANTING	PARKING*	LANE	R/W BEHIND SIDEWALK		CURB	GUTTER	
	A	B	C	D	E	F	R/W	H	I	J
1 LANES	10	5	8	6	12	1	48	3	0.5	1
SEE STANDARD PLAN 4-6A FOR MINIMUM STRUCTURAL DESIGN AND STREET CROSS SLOPE DESIGN										
SEE MINIMUM STREET DESIGN STANDARDS TABLE FOR ADDITIONAL DESIGN ELEMENTS										
ADT 0-500										
A= PRIVATE UTILITY EASEMENT										
* - BLOCK SPACING >350' PARKING BULB-OUTS ARE REQUIRED (STD PLAN NO. 4-13B)										
A 100' NO PARKING ZONE IN THE CENTER OF THE BLOCK IS REQUIRED FOR EMERGENCY VEHICLE ACCESS (EDDS 4C.070)										

APPROVED BY	REVISED DATE	CITY OF OLYMPIA	STD. PLAN NO.
	11/20/07	LOCAL ACCESS STREET	4-2J
CITY ENGINEER			

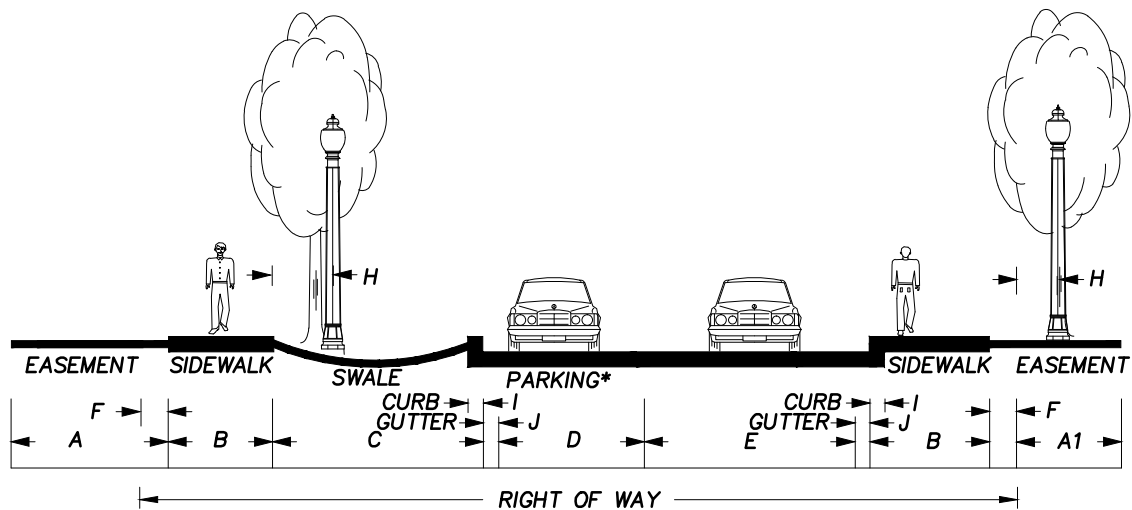

DIMENSIONS = FEET

LOCAL ACCESS STREET	EASEMENT	TREE EASEMENT	SIDEWALK	SWALE	PARKING*	LANE	R/W BEHIND SIDEWALK		CURB	GUTTER	
	A	A1	B	C	D	E	F	R/W	H	I	J
1 LANES	10	6	5	12	6	12	1	44	3	0.5	1
SEE STANDARD PLAN 4-6A FOR MINIMUM STRUCTURAL DESIGN AND STREET CROSS SLOPE DESIGN											
SEE MINIMUM STREET DESIGN STANDARDS TABLE FOR ADDITIONAL DESIGN ELEMENTS											
ADT 0-500											
A= PRIVATE UTILITY EASEMENT											
* - BLOCK SPACING >350' PARKING BULB-OUTS ARE REQUIRED (STD PLAN NO. 4-13B)											
A 100' NO PARKING ZONE IN THE CENTER OF THE BLOCK IS REQUIRED FOR EMERGENCY VEHICLE ACCESS (EDDS 4C.070)											

APPROVED BY	REVISED DATE	CITY OF OLYMPIA	STD. PLAN NO.
CITY ENGINEER	11/20/07	LOCAL ACCESS STREET WITH SWALE	4-2J1

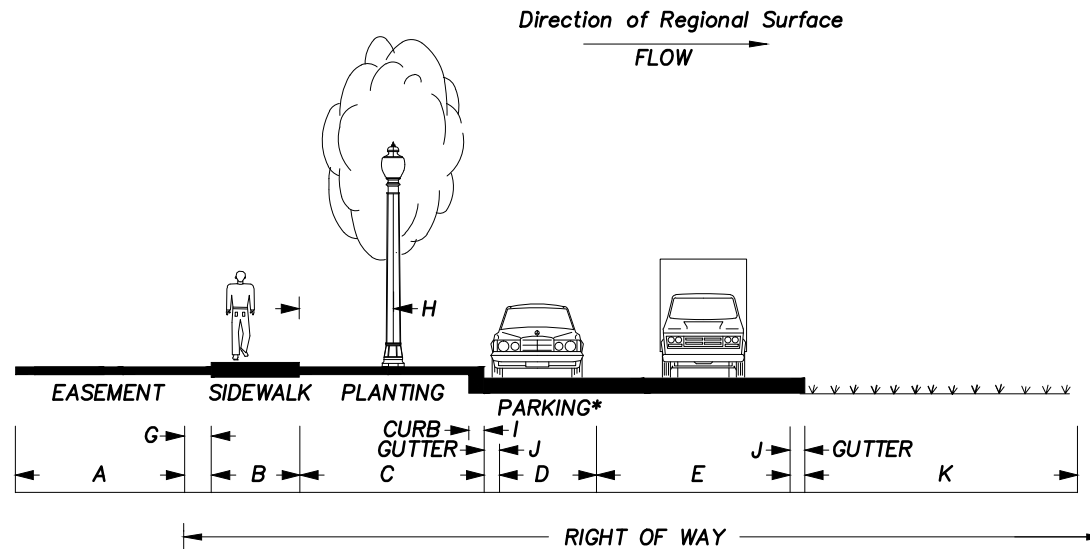

DIMENSIONS = FEET

LOCAL ACCESS STREET	EASEMENT	SIDEWALK	PLANTING	PARKING*	LANE	R/W BEHIND SIDEWALK	R/W	CURB	GUTTER	DISPERSION AREA		
	A	B	C	D	E	G		H	I	J	K	
1 LANES	10	5	8	6	13	1	46	3	0.5	1	11	SEE STANDARD PLAN 4-6A FOR MINIMUM STRUCTURAL DESIGN AND STREET CROSS SLOPE DESIGN
												SEE MINIMUM STREET DESIGN STANDARDS TABLE FOR ADDITIONAL DESIGN ELEMENTS
												ADT 0-500
C+K = COMPOST AMENDED SOILS K = NATIVE VEGETATION												
A = PRIVATE UTILITY EASEMENT + PUBLIC STORMWATER EASEMENT												
* - BLOCK SPACING >350" PARKING BULB-OUTS ARE REQUIRED (STD PLAN NO. 4-13B)												
A 100' NO PARKING ZONE IN THE CENTER OF THE BLOCK IS REQUIRED FOR EMERGENCY VEHICLE ACCESS (EDDS 4C.070)												

APPROVED BY	REVISED DATE	CITY OF OLYMPIA LOCAL ACCESS STREET WITH FULL DISPERSION	STD. PLAN NO.
CITY ENGINEER	2/22/08		4-2JX2

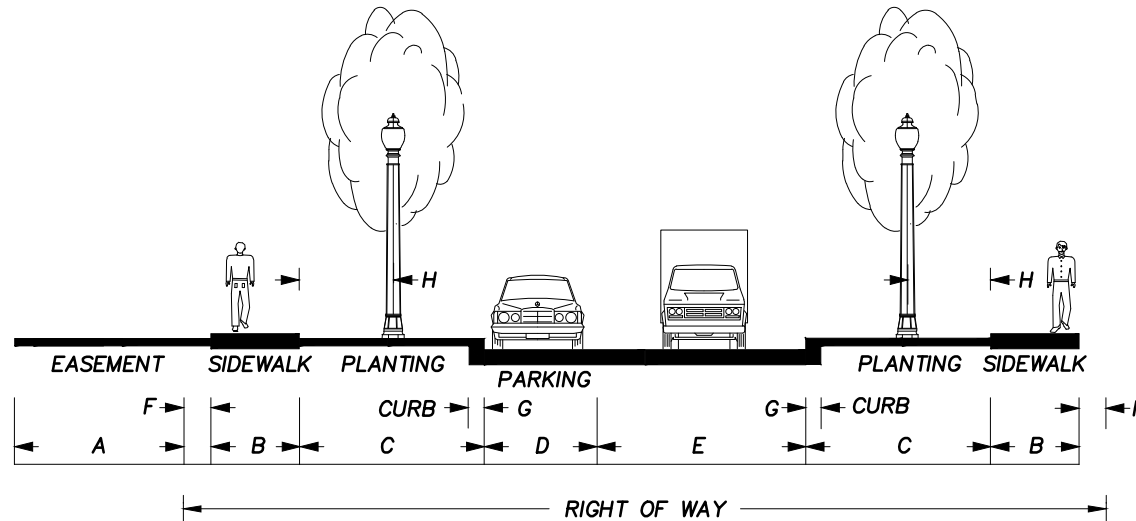

DIMENSIONS = FEET

LOCAL ACCESS	EASEMENT	SIDEWALK	PLANTING	PARKING	LANE	R/W BEHIND SIDEWALK	CURB			SEE STANDARD PLAN 4-6A FOR MINIMUM STRUCTURAL DESIGN AND STREET CROSS SLOPE DESIGN
	A	B	C	D	E	F	R/W	G	H	
1 LANE	10	5	8	7	13	1	48	0.5	4	SEE MINIMUM STREET DESIGN STANDARDS TABLE FOR ADDITIONAL DESIGN ELEMENTS
A= PRIVATE UTILITY EASEMENT										ADT 0-500

APPROVED BY	REVISED DATE	CITY OF OLYMPIA LOCAL ACCESS STREET BLOCK SPACING < 350 FT	STD. PLAN NO.
CITY ENGINEER	6/14/95		4-2K

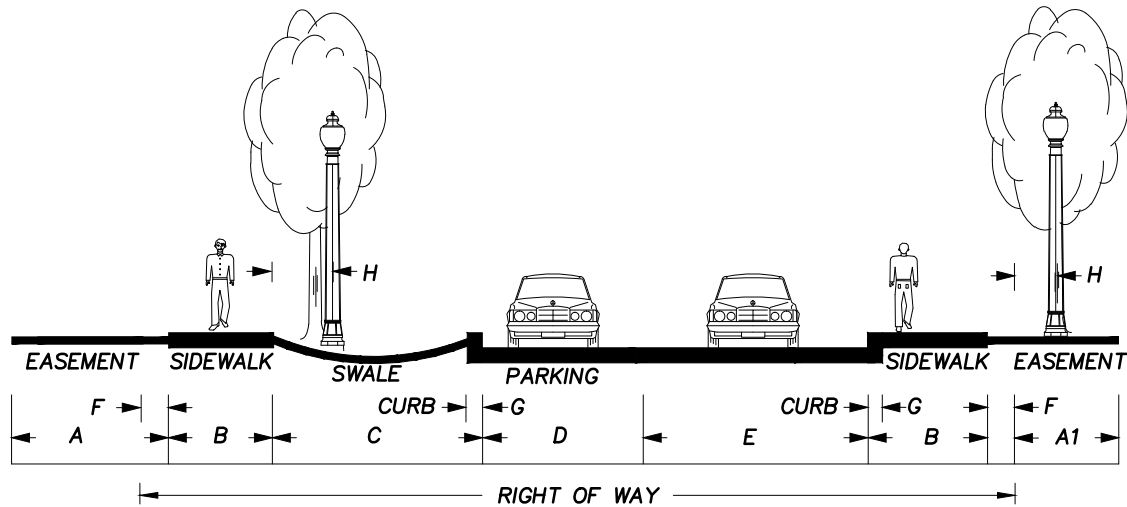

DIMENSIONS = FEET

LOCAL ACCESS STREET	EASEMENT	TREE EASEMENT	SIDEWALK	SWALE	PARKING	LANE	R/W BEHIND SIDEWALK		CURB		
	A	A1	B	C	D	E	F	R/W	G	H	
2 LANES	10	6	5	12	7	13	1	44	0.5	3	
A1= PRIVATE UTILITY EASEMENT											
											ADT 0-500
											SEE STANDARD PLAN 4-6A FOR MINIMUM STRUCTURAL DESIGN AND STREET CROSS SLOPE DESIGN
											SEE MINIMUM STREET DESIGN STANDARDS TABLE FOR ADDITIONAL DESIGN ELEMENTS

APPROVED BY	REVISED DATE	CITY OF OLYMPIA	STD. PLAN NO.
	6/14/95	LOCAL ACCESS STREET WITH SWALE BLOCK SPACING < 350 FT	4-2K1
CITY ENGINEER			

SEE RESTORATION *NOTE BELOW

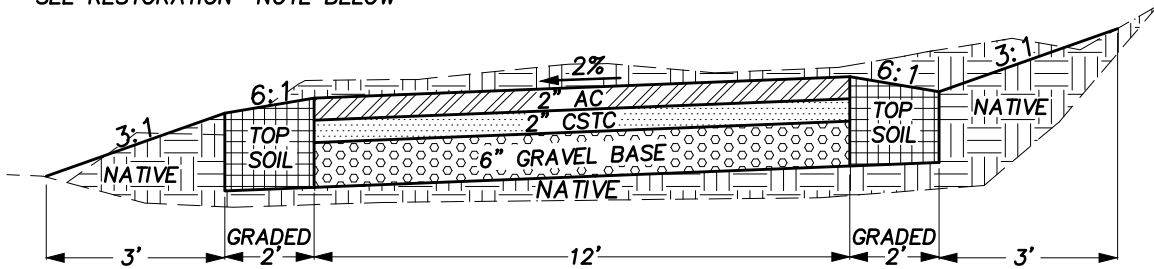

COMMUTER MULTI-USE

SEE RESTORATION *NOTE BELOW

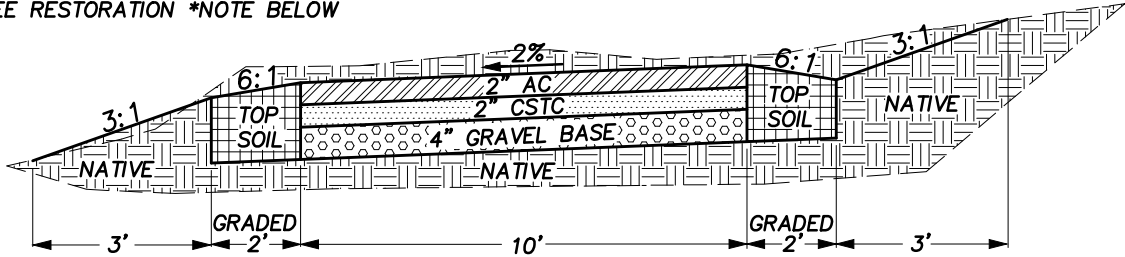

NEIGHBORHOOD CONNECTOR

SEE RESTORATION *NOTE BELOW

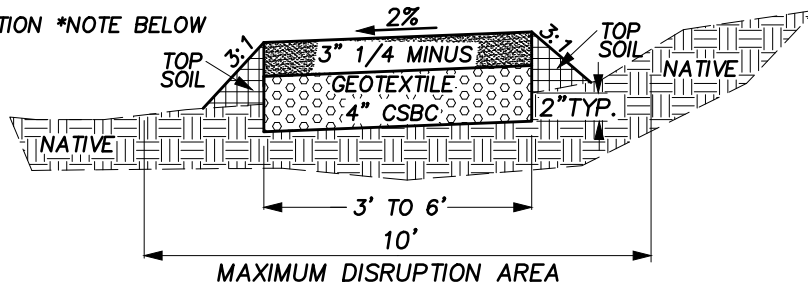

RECREATIONAL PEDESTRIAN

NOTE:

SEE EDDS SECTION 4E FOR DETAILED DESCRIPTION AND DESIGN STANDARDS TABLE.
 *AREAS DISTURBED BY CONSTRUCTION AND WHERE TOP SOIL IS PLACED SHALL BE RE-SEEDED WITH GRASS FOR RESTORATION.

NTS

APPROVED BY	REVISED DATE	CITY OF OLYMPIA	STD. PLAN NO.
CITY ENGINEER	11/10/2011	TRAILS / SHARED-USE PATH	4-2L

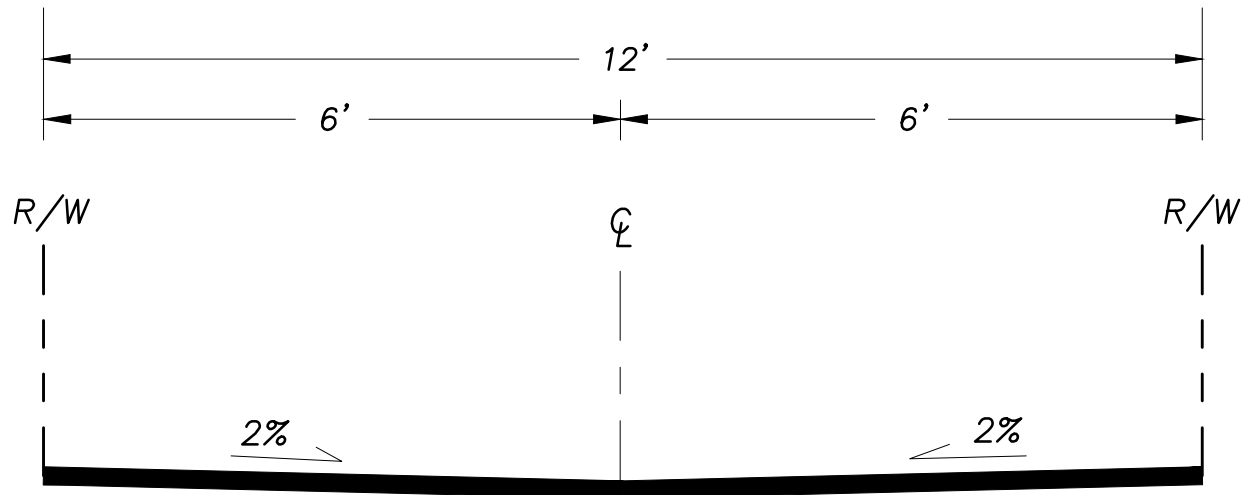

NOTE:

- SEE STD. PLAN NO. 4-6A FOR PAVEMENT SECTIONS.
- DRAINAGE DESIGN WILL BE REQUIRED.

APPROVED BY	REVISED DATE	CITY OF OLYMPIA	STD. PLAN NO.
	6/14/95	ROADWAY PAVEMENT FOR COMMERCIAL ALLEYS	4-3
CITY ENGINEER			

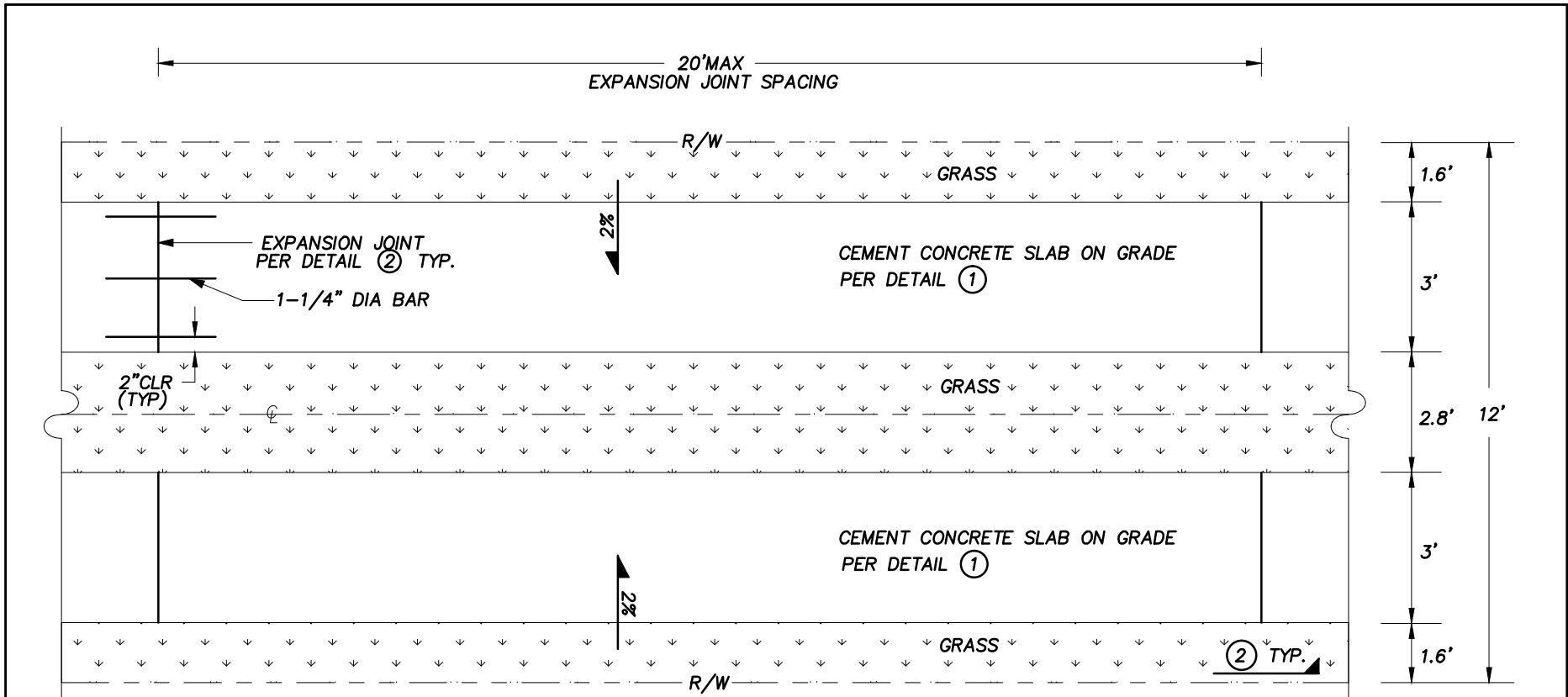

NOTE:

- ALL MATERIAL AND WORK SHALL BE IN ACCORDANCE WITH THE REQUIREMENTS OF WSDOT STANDARD SPECIFICATIONS.
- ALL CONCRETE SHALL BE CLASS 4000.
- DESIGN OF CONCRETE PAVEMENT IS BASED ON A MINIMUM ALLOWABLE SOIL BEARING PRESSURE OF 1500 PSF.
- IF SOIL BEARING PRESSURE IS LESS THAN 1500 PSF, STRUCTURAL DESIGN CHANGES SHALL BE MADE.
- MAINTENANCE OF CEMENT CONCRETE SLAB WILL BE THE RESPONSIBILITY OF THE CITY OF OLYMPIA PUBLIC WORKS DEPARTMENT.
- ALL MAINTENANCE REQUIRED WITHIN THE GRASS AREA SHALL BE THE RESPONSIBILITY OF THE ADJACENT PROPERTY OWNERS.
- DRAINAGE DESIGN WILL BE REQUIRED.

APPROVED BY	REVISED DATE	CITY OF OLYMPIA	STD. PLAN NO.
	4/26/95	ROADWAY PAVEMENT FOR RESIDENTIAL ALLEYS – PLAN VIEW	4-4A
CITY ENGINEER			

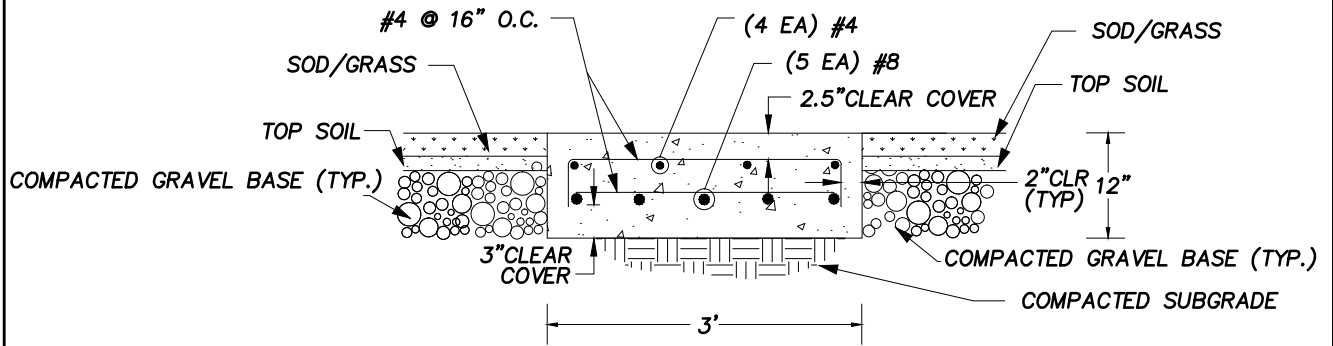
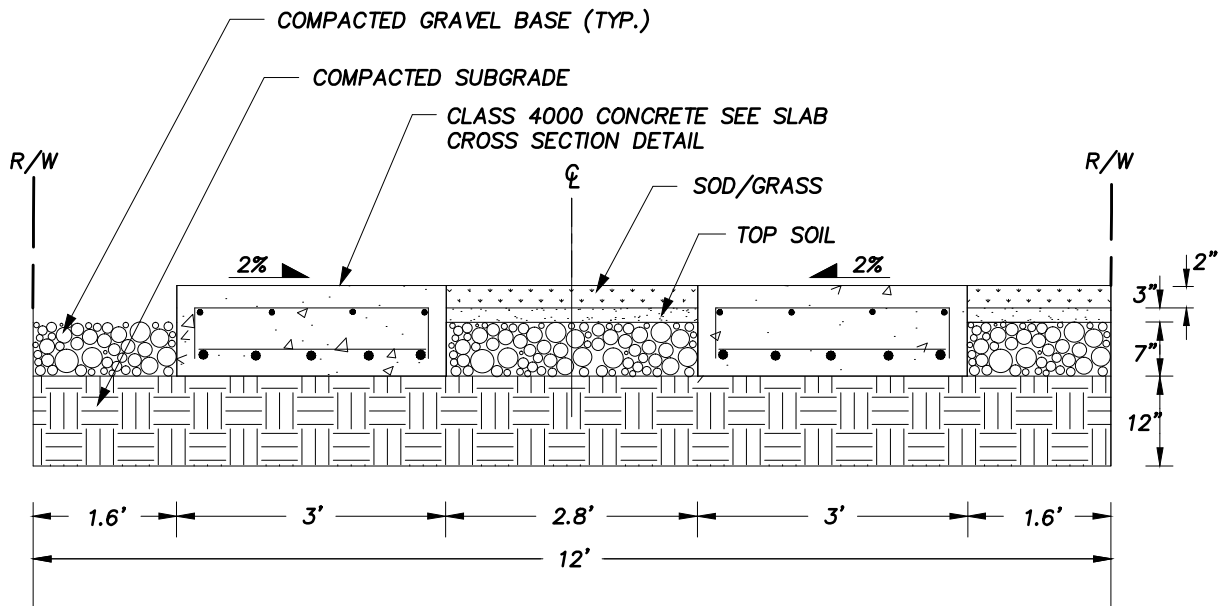

1 TYPICAL SLAB CROSS SECTION
N.T.S.

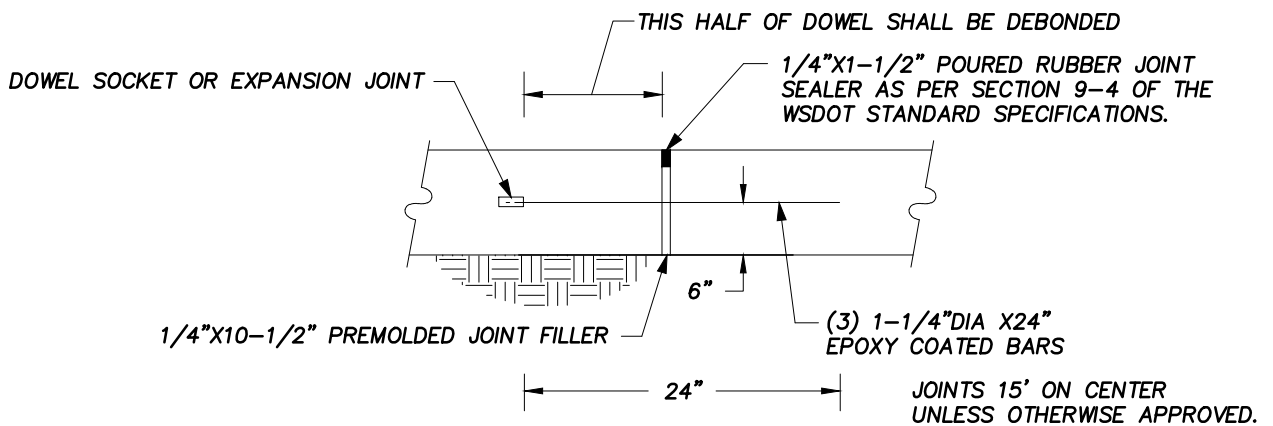

2 TYPICAL CONSTRUCTION JOINT
N.T.S.

APPROVED BY	REVISED DATE	CITY OF OLYMPIA	STD. PLAN NO.
	7/10/06	ROADWAY PAVEMENT FOR RESIDENTIAL ALLEYS SECTION VIEWS	4-4B
CITY ENGINEER			

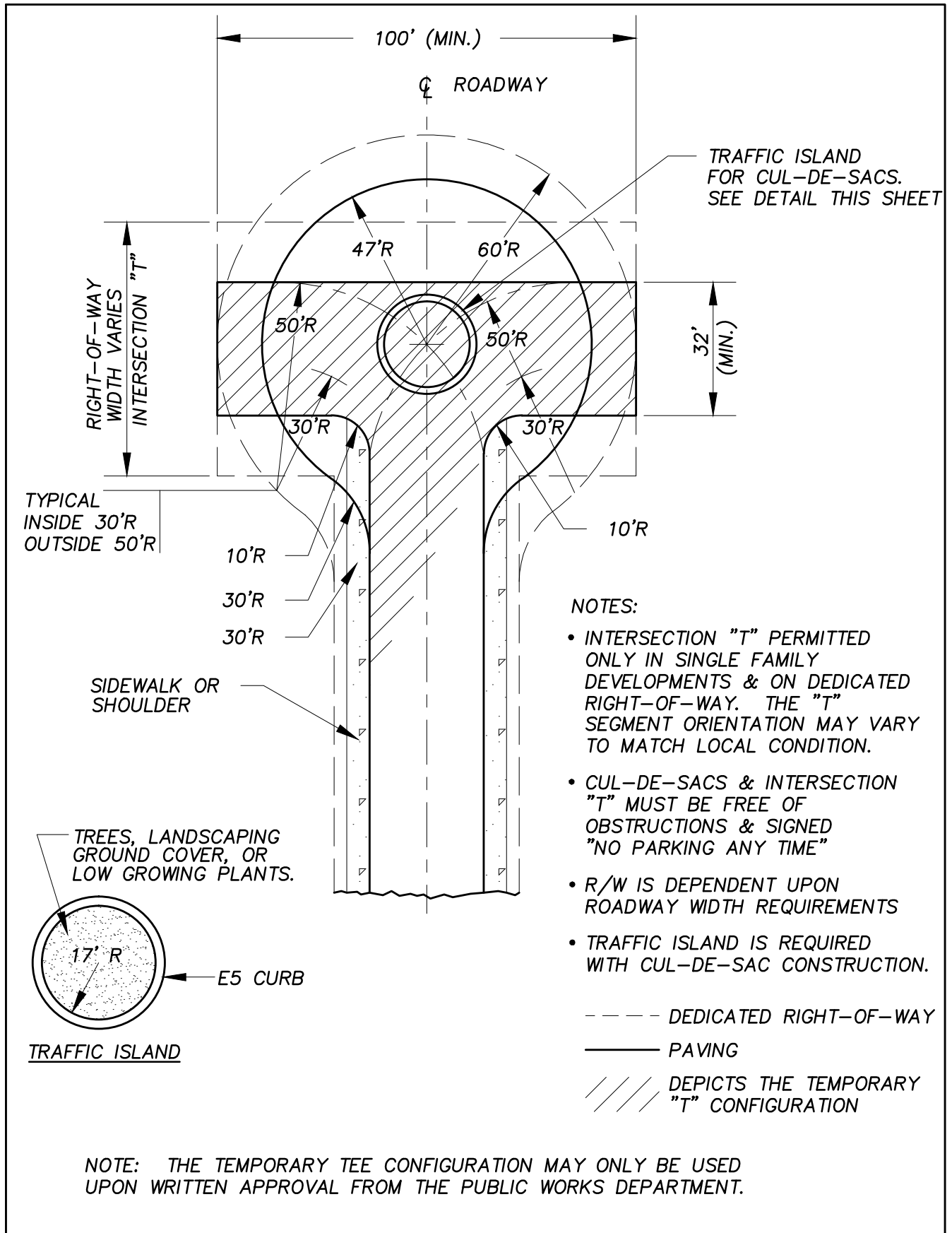

APPROVED BY	REVISED DATE	CITY OF OLYMPIA	STD. PLAN NO.
	11/1/96	CUL-DE-SAC OR TEMPORARY INTERSECTION "T"	4-5
CITY ENGINEER			

PAVEMENT DESIGN—CONSTANTS

	STD. PLAN 4-2A & B	STD. PLAN 4-2A THRU 4-2G	STD. PLAN 4-2C THRU 4-2G	STD. PLAN 4-2H THRU 4-2I	STD. PLAN 4-2J THRU 4-3
	ARTERIAL	INDUSTRIAL COLLECTOR	MAJOR COLLECTOR	NEIGHBORHOOD COLLECTOR	LOCAL ACCESS & COMMERCIAL ALLEYS
AADT	14,000– 40,000	3,000– 14,000	3,000– 14,000	500– 3,000	0–500
% AADTT	8	15	15	5	5
GROWTH RATE	5	5	5	5	2
LANE FACTOR	0.5	0.5	0.5	0.5	0.5
DESIGN EAL	4,000,000	6,000,000	2,400,000	280,000	50,000
R%	95	95	90	85	80
S _o	0.45	0.45	0.45	0.45	0.45
P _i	4.20	4.20	4.20	4.20	4.20
P _t	2.5	2.5	2.4	2.3	2.2
ΔPSI	1.7	1.7	1.8	1.9	2.0

MINIMUM PAVEMENT SECTION WITHOUT PAVEMENT DESIGN *

AC	6"	6"	4"	4"	3"
CSTC	2"	2"	2"	2"	2"
GRAVEL BASE (BALLAST)	25"	28"	25"	16"	10"

MINIMUM PAVEMENT SECTION WITH PAVEMENT DESIGN *

AC	4"	4"	3"	3"	3"
CSTC	2"	2"	2"	2"	2"
GRAVEL BASE	6"	10"	6"	6"	4"

NOTE:

- USE 2% STREET CROSS SLOPE AND NO MORE THAN 33 FEET OF ROADWAY SLOPED IN ANY DIRECTION.
- INVERTED CROWN MAY BE ALLOWED IN BOULEVARD STREET SECTIONS UPON PRIOR APPROVAL BY CITY.

* PAVEMENT DESIGN IS PER AASHTO DESIGN GUIDELINES AND CERTIFIED CALIFORNIA BEARING RATIO (CBR) SOILS TESTS. SEE STANDARD DRAWING 4-6B FOR PAVEMENT DESIGN WORKSHEET.

APPROVED BY	REVISED DATE	CITY OF OLYMPIA	STD. PLAN NO.
	11/1/96	PAVEMENT DESIGN	4-6A
CITY ENGINEER			

PAVEMENT DESIGN – AASHTO METHOD

SEE PREVIOUS PAGE FOR INPUT IN DOUBLE BOXES ()

SOIL TEST RESULTS
MUST BE SUBMITTED
WITH THIS WORKSHEET.

STREET CLASSIFICATION:

INITIAL AADT: % OF AADTT:

GROWTH RATE:

DESIGN LIFE: 20 YEARS

DESIGN (EAL):

RELIABILITY LEVEL (R%): % STANDARD DEVIATION (S_o):

INITIAL SERVICEABILITY INDEX (P_i): 4.2

TERMINAL SERVICEABILITY INDEX (P_t):

$\Delta PSI = P_i - P_t = 4.2 - \text{[]} = \text{[]}$

SUBGRADE: $M_r = 1500 \times CBR^*$

CBRVALUE* FROM SOILTEST= => M_r psi

USING AASHTO DESIGN METHOD:** SN = , PROVIDE NOMOGRAPH OR CALCULATIONS.

$$SN = (A_1 D_1) + (A_2 D_2) + (A_3 D_3) + (A_4 D_4)$$

STRUCTURAL COEFFICIENT: CLASS B ASPHALT CONCRETE
 ASPHALT TREATED BASE
 CSTC OR CSBC
 BALLAST

A₁=0.42
 A₂=0.34
 A₃=0.14
 A₄=0.10

* AASHTO T193: THE CALIFORNIA BEARING RATIO
 ASTM D1883: BEARING OF LABORATORY COMPACTED SOILS

** AASHTO GUIDE FOR DESIGN OF PAVEMENT STRUCTURES

APPROVED BY	REVISED DATE	CITY OF OLYMPIA	STD. PLAN NO.
	11/1/96	PAVEMENT DESIGN	4-6B
CITY ENGINEER		WORKSHEET	

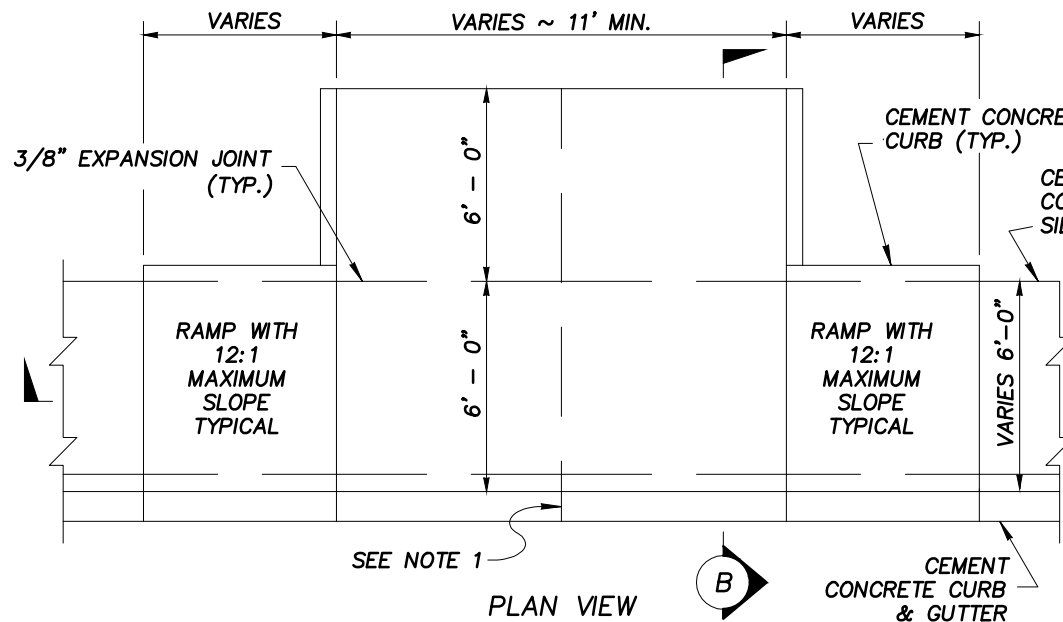

NOTE:
 CEMENT CONCRETE TRAFFIC CURB AND GUTTER WHERE NOT ADJACENT TO PLANNED OR EXISTING BIKE LANE. USE 4-14 WHEN BIKE LANE IS PRESENT OR PLANNED.

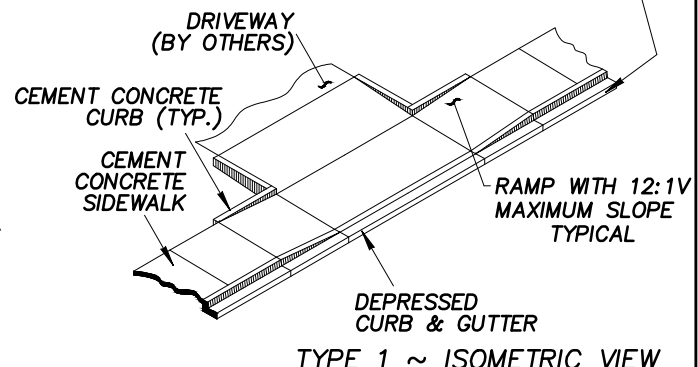

CEMENT CONCRETE DRIVEWAY ENTRANCE TYPE 1

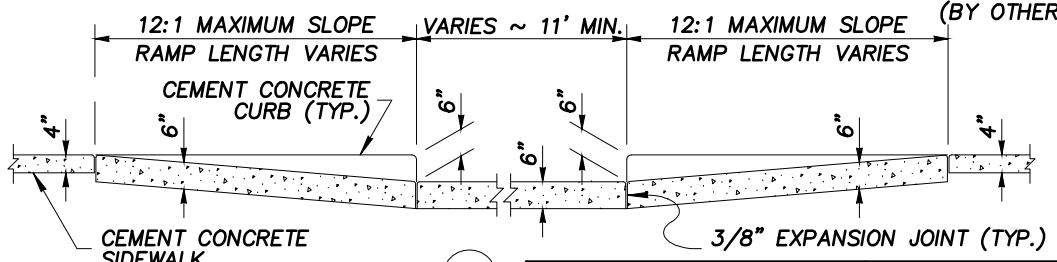
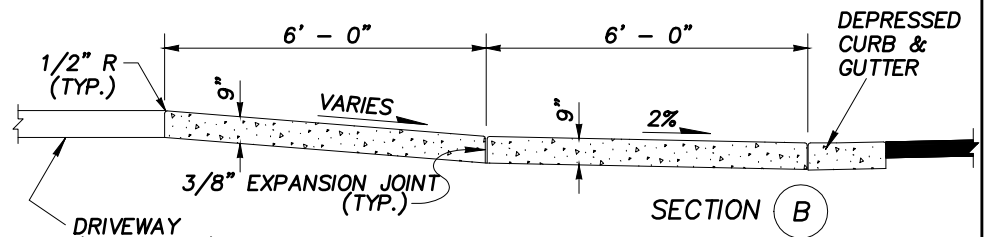

- NOTES
1. WHEN THE DRIVEWAY WIDTH EXCEEDS 15 FEET, CONSTRUCT A FULL DEPTH EXPANSION JOINT WITH 3/8" JOINT FILLER ALONG THE DRIVEWAY CENTERLINE. CONSTRUCT EXPANSION JOINTS PARALLEL WITH THE CENTERLINE AS REQUIRED AT 15' MAXIMUM SPACING WHEN DRIVEWAY WIDTHS EXCEED 30'.
 2. FORM AND SUBGRADE INSPECTION REQUIRED BEFORE PLACING CONCRETE.
 3. BROOM FINISH LONGITUDINALLY WITH LIGHT BROOM FINISH INCLUDING CURB FACE.

APPROVED BY	REVISED DATE	CITY OF OLYMPIA	STD. PLAN NO.
CITY ENGINEER	11/14/2011		
		CEMENT CONCRETE DRIVEWAY ENTRANCE TYPE 1	4-7A

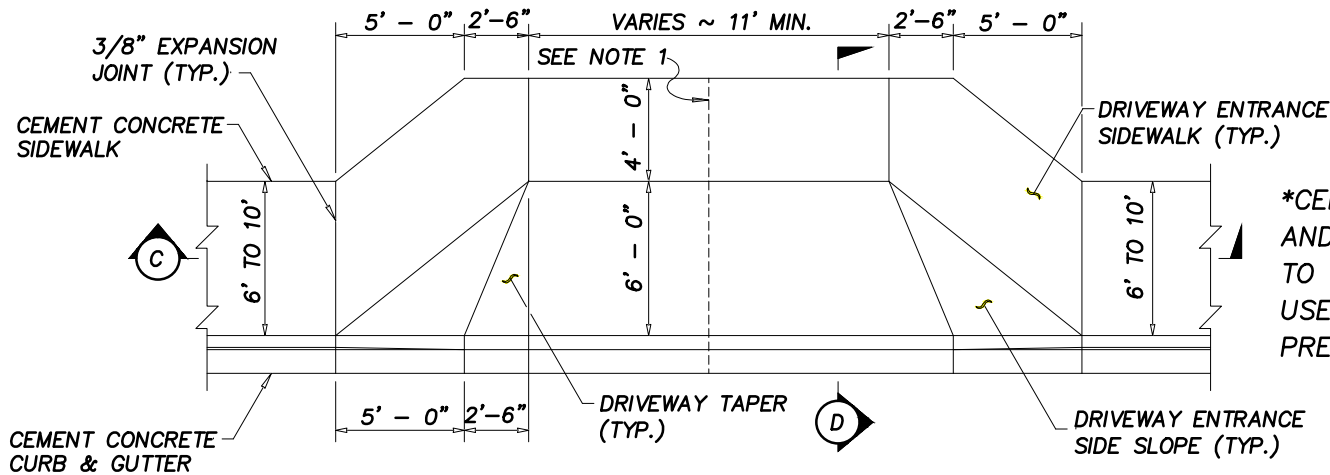

*CEMENT CONCRETE TRAFFIC CURB AND GUTTER WHERE NOT ADJACENT TO EXISTING OR PLANNED BIKE LANE. USE 4-14 WHEN BIKE LANE IS PRESENT OR PLANNED.

PLAN VIEW

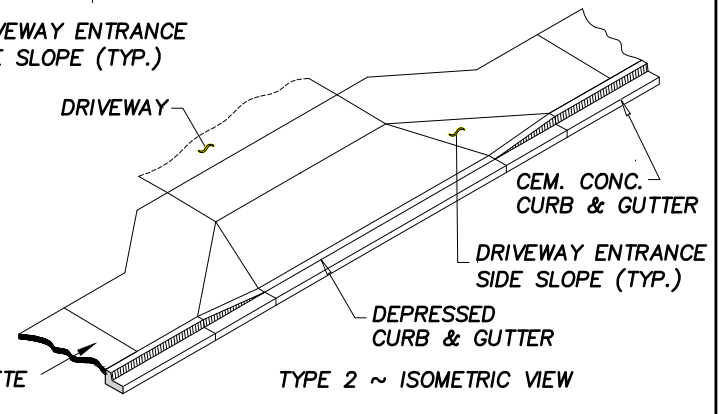

TYPE 2 ~ ISOMETRIC VIEW

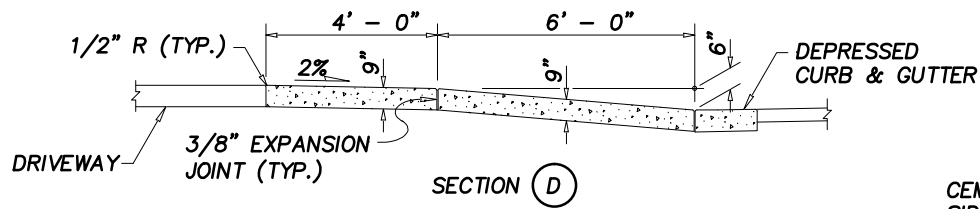

SECTION D

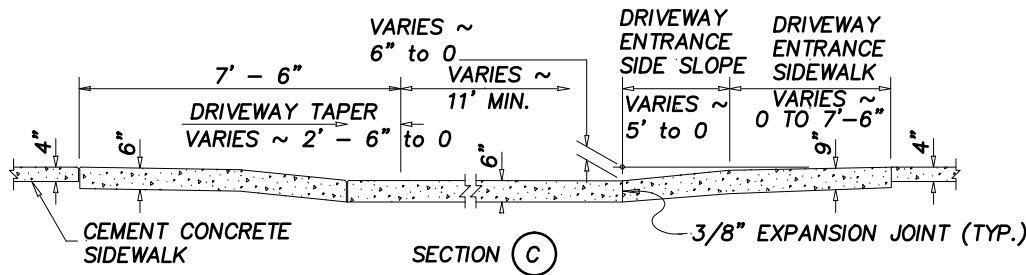

SECTION C

NOTES

1. WHEN THE DRIVEWAY WIDTH EXCEEDS 15 FEET, CONSTRUCT A FULL DEPTH EXPANSION JOINT WITH 3/8" JOINT FILLER ALONG THE DRIVEWAY CENTERLINE. CONSTRUCT EXPANSION JOINTS PARALLEL WITH THE CENTERLINE AS REQUIRED AT 15' MAXIMUM SPACING WHEN DRIVEWAY WIDTHS EXCEED 30'.
2. FORM AND SUBGRADE INSPECTION REQUIRED BEFORE PLACING CONCRETE.
3. BROOM FINISH LONGITUDINALLY WITH LIGHT BROOM FINISH INCLUDING CURB FACE.

APPROVED BY	REVISED DATE	CITY OF OLYMPIA CEMENT CONCRETE DRIVEWAY ENTRANCE TYPE 2	STD. PLAN NO.
CITY ENGINEER	10/27/08		4-7B

CEMENT CONCRETE DRIVEWAY ENTRANCE TYPE 3

*CEMENT CONCRETE TRAFFIC CURB AND GUTTER WHERE NOT ADJACENT TO EXISTING OR PLANNED BIKE LANE. USE 4-14 WHEN BIKE LANE IS PRESENT OR PLANNED.

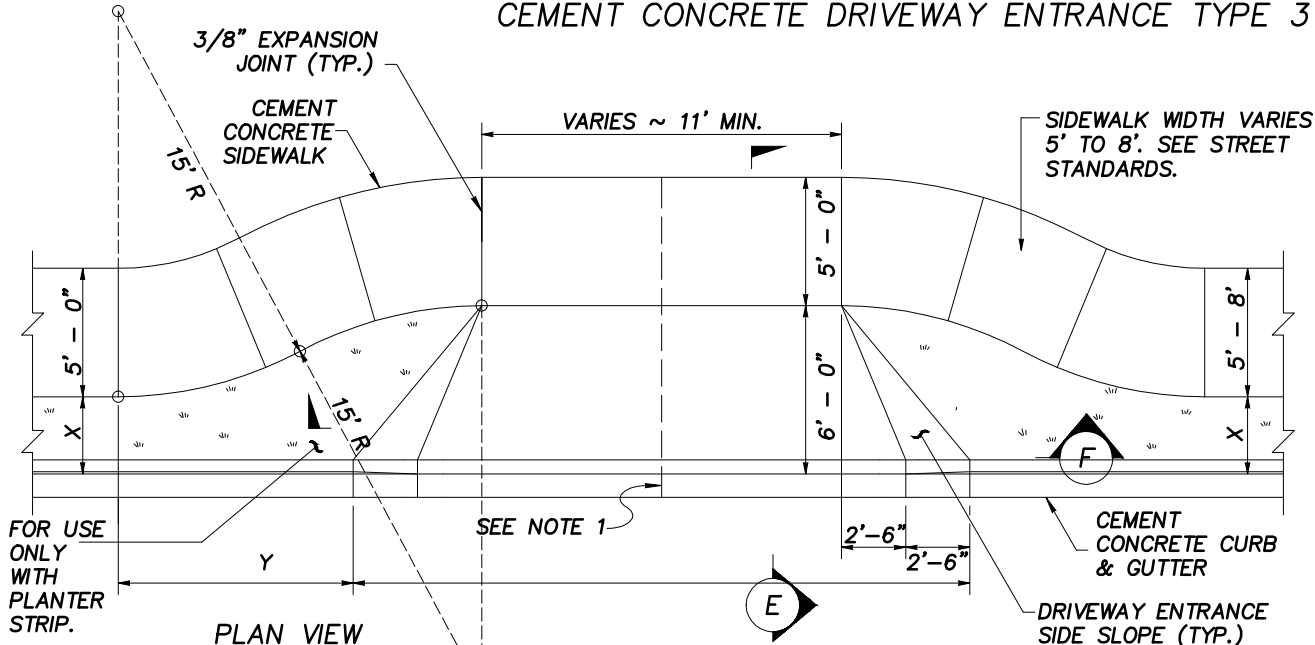

NOTES

1. WHEN THE DRIVEWAY WIDTH EXCEEDS 15 FEET, CONSTRUCT A FULL DEPTH EXPANSION JOINT WITH 3/8" JOINT FILLER ALONG THE DRIVEWAY CENTERLINE. CONSTRUCT EXPANSION JOINTS PARALLEL WITH THE CENTERLINE AS REQUIRED AT 15' MAXIMUM SPACING WHEN DRIVEWAY WIDTHS EXCEED 30'.
2. FORM AND SUBGRADE INSPECTION REQUIRED BEFORE PLACING CONCRETE.
3. BROOM FINISH LONGITUDINALLY WITH LIGHT BROOM FINISH INCLUDING CURB FACE.
4. SIDEWALK WIDTH VARIES. SEE CHAPTER 4. 4-2 SERIES OF DRAWINGS FOR APPLICABLE SIDEWALK WIDTH.

X	Y
3' - 0"	13' - 1"
4' - 0"	10' - 9"
5' - 0"	7' - 8"

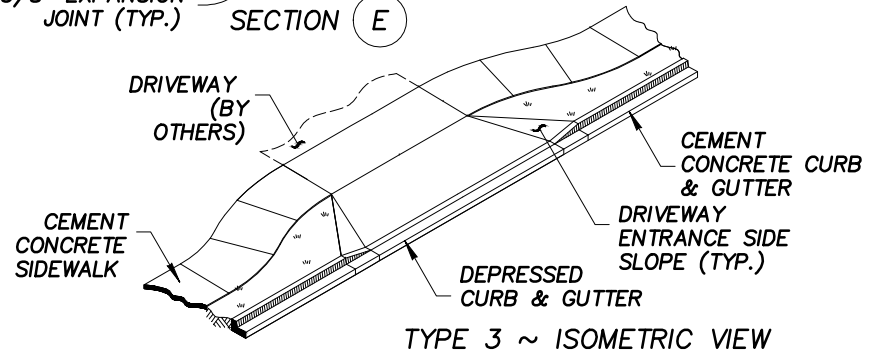
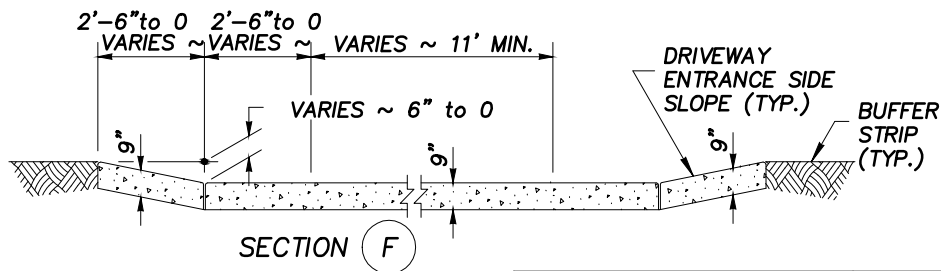
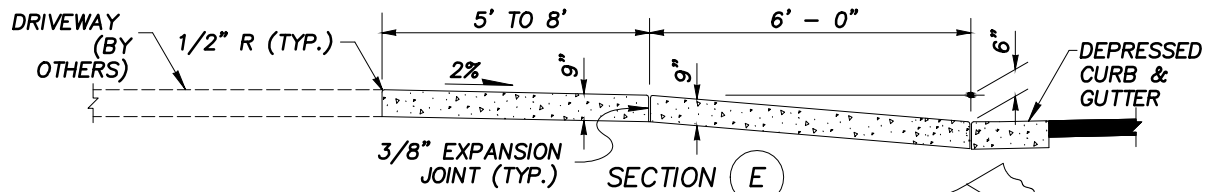

APPROVED BY	REVISED DATE	CITY OF OLYMPIA CEMENT CONCRETE DRIVEWAY ENTRANCE TYPE 3	STD. PLAN NO.
CITY ENGINEER	1/30/2012		4-7C

CEMENT CONCRETE DRIVEWAY ENTRANCE TYPE 4

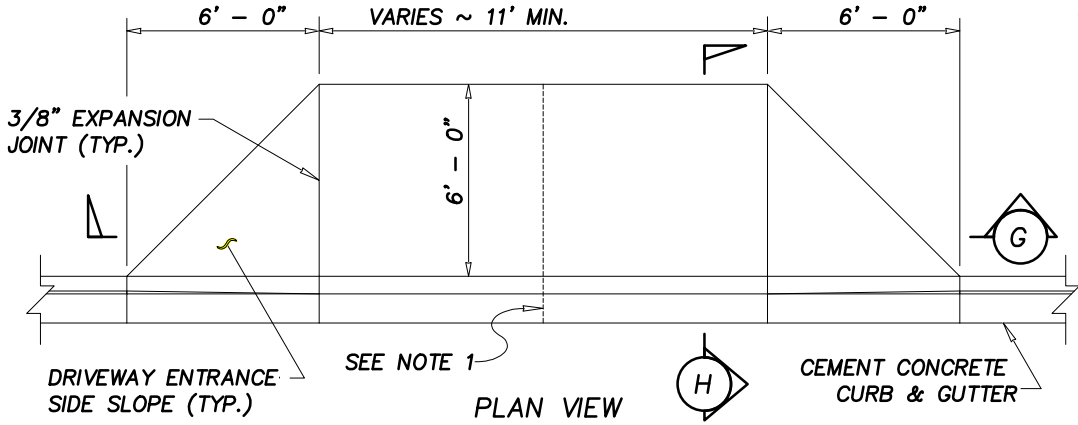

*CEMENT CONCRETE TRAFFIC CURB AND GUTTER WHERE NOT ADJACENT TO EXISTING OR PLANNED BIKE LANE. USE 4-14 WHEN BIKE LANE IS PRESENT OR PLANNED.

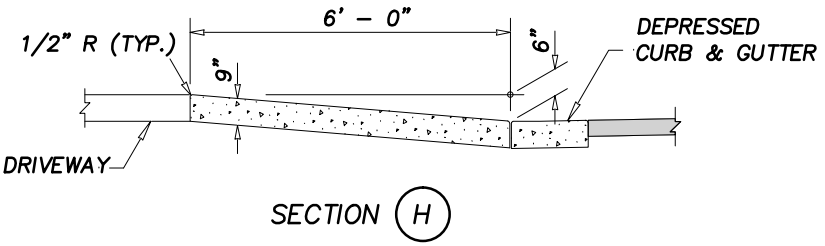
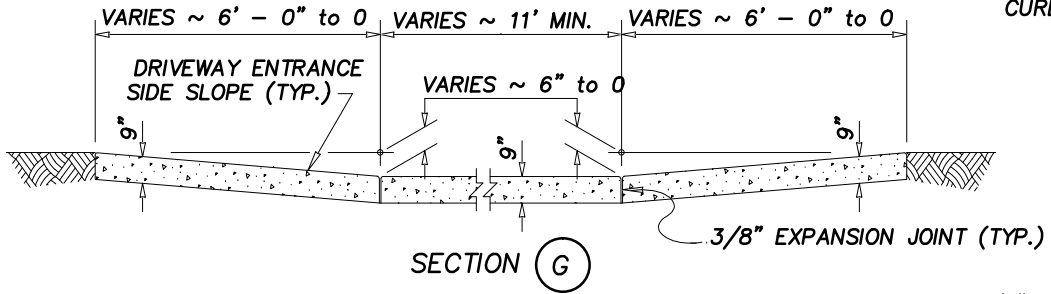
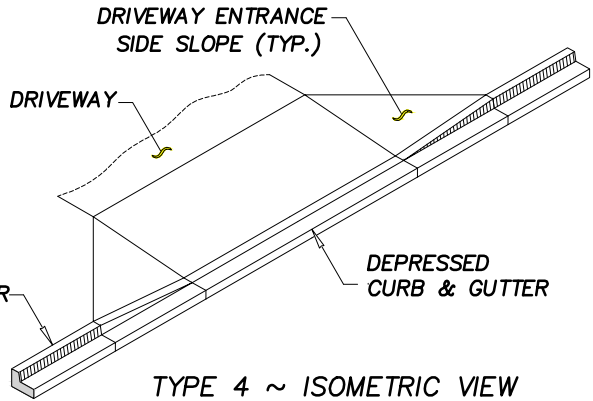

- NOTES**
1. WHEN THE DRIVEWAY WIDTH EXCEEDS 15 FEET, CONSTRUCT A FULL DEPTH EXPANSION JOINT WITH 3/8" JOINT FILLER ALONG THE DRIVEWAY CENTERLINE. CONSTRUCT EXPANSION JOINTS PARALLEL WITH THE CENTERLINE AS REQUIRED AT 15' MAXIMUM SPACING WHEN DRIVEWAY WIDTHS EXCEED 30'.
 2. FORM AND SUBGRADE INSPECTION REQUIRED BEFORE PLACING CONCRETE.
 3. BROOM FINISH LONGITUDINALLY WITH LIGHT BROOM FINISH INCLUDING CURB FACE.

APPROVED BY	REVISED DATE	CITY OF OLYMPIA CEMENT CONCRETE DRIVEWAY ENTRANCE TYPE 4	STD. PLAN NO.
CITY ENGINEER	10/28/08		4-7D

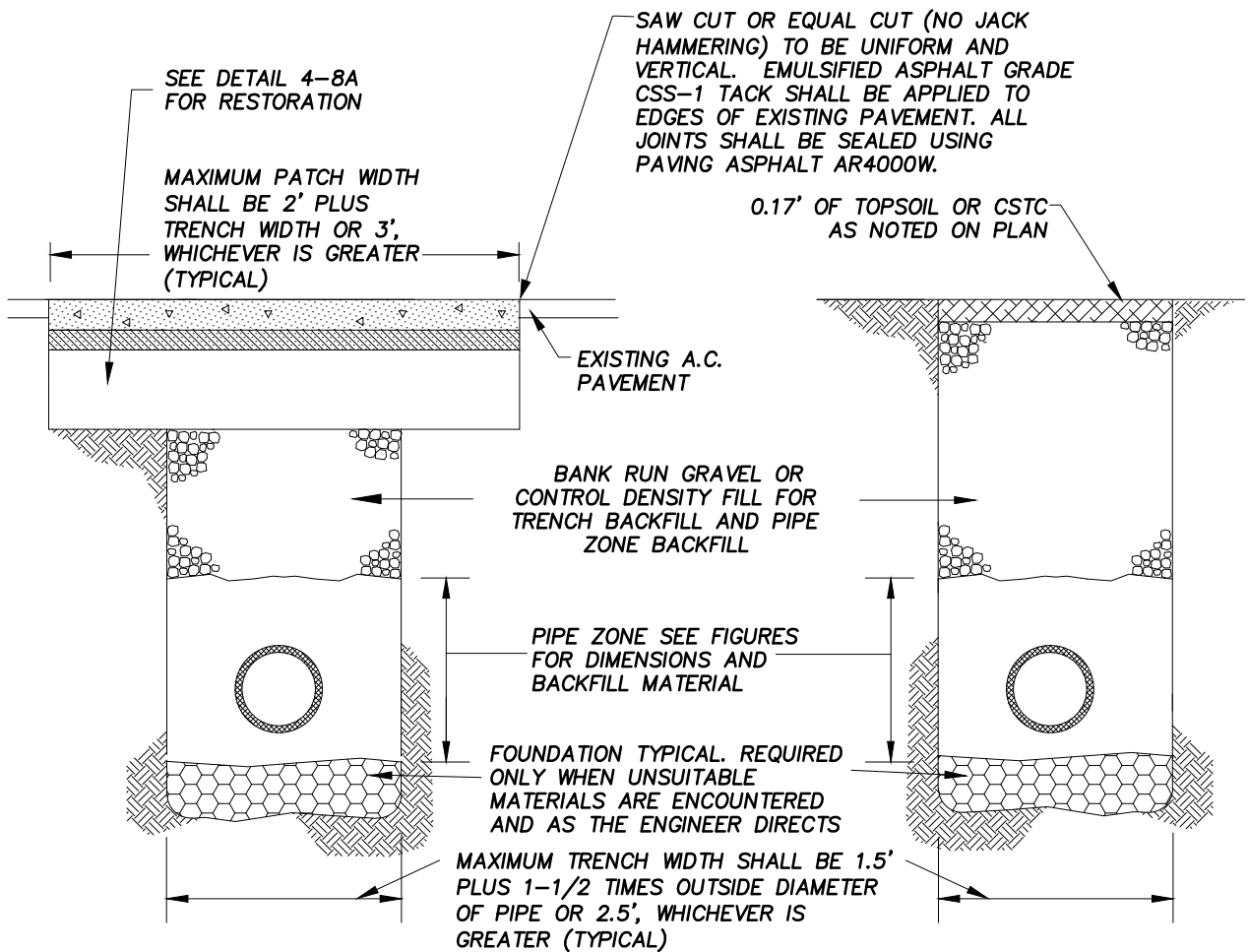

CONCRETE AND DUCTILE IRON PIPE

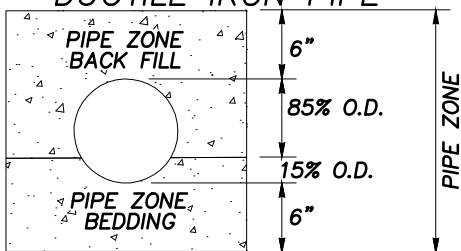

THERMOPLASTIC PIPE

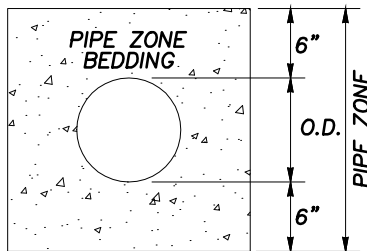

METAL PIPE

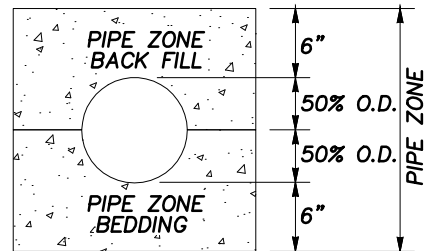

NOTES:

1. ALL MATERIALS EXCEPT A.C.P. AND BEDDING MATERIAL SHALL BE COMPACTED IN 6-INCH MAXIMUM LIFTS TO 95% DENSITY.
2. PIPE ZONE BEDDING SHALL CONFORM TO SECTION 9-03.12(3) OF WSDOT/APWA STANDARD SPECIFICATIONS EXCEPT 100% SHALL PASS 1".
3. COMPACTION: BEDDING AND BACKFILL WITHIN THE PIPE ZONE SHALL BE COMPACTED TO 95% MAX. AS DETERMINED BY ASTM D1557. BACKFILL ABOVE THE PIPE ZONE SHALL BE COMPACTED TO 85% IN UNPAVED AREA, AND 95% IN PAVED OR SHOULDER AREAS AS DETERMINED BY ASTM D1557.
4. ALL MATERIALS, WORKMANSHIP, AND INSTALLATION SHALL BE IN CONFORMANCE WITH THE MOST CURRENT WSDOT STANDARD SPECIFICATIONS AS AMENDED BY THE CITY OF OLYMPIA PUBLIC WORKS STANDARDS.
5. FOR LONGITUDINAL TRENCH CUTS WITHIN TRAVEL LANE, CITY REQUIRES MINIMUM OF ONE LANE OVERLAY IN ADDITION TO TRENCH PATCH DETAIL FOR CONCRETE AND ASPHALT ROADWAYS. ADDITIONAL OVERLAY MAY BE REQUIRED DEPENDING ON LOCATION AND TRENCHING WIDTH. SEE SECTION 4B.180 TRENCH BACKFILL AND 4B.175 PAVEMENT RESTORATION FOR DETAIL REQUIREMENTS.

APPROVED BY	REVISED DATE	CITY OF OLYMPIA	STD. PLAN NO.
	12/08/11	TRENCH-PAVEMENT RESTORATION DETAIL	4-8
CITY ENGINEER			

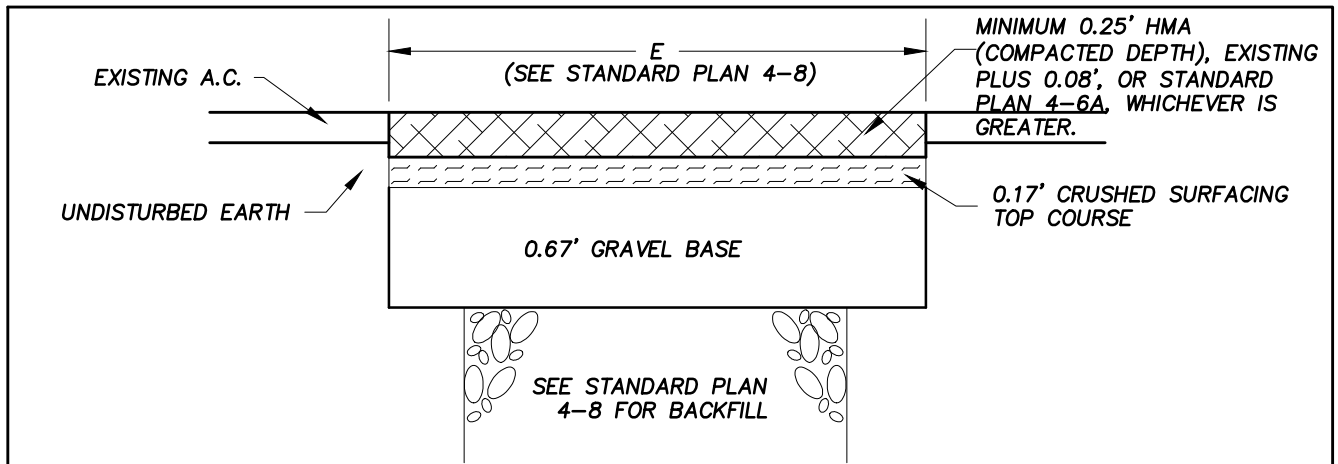

CASE 1: (WITHOUT BASE)

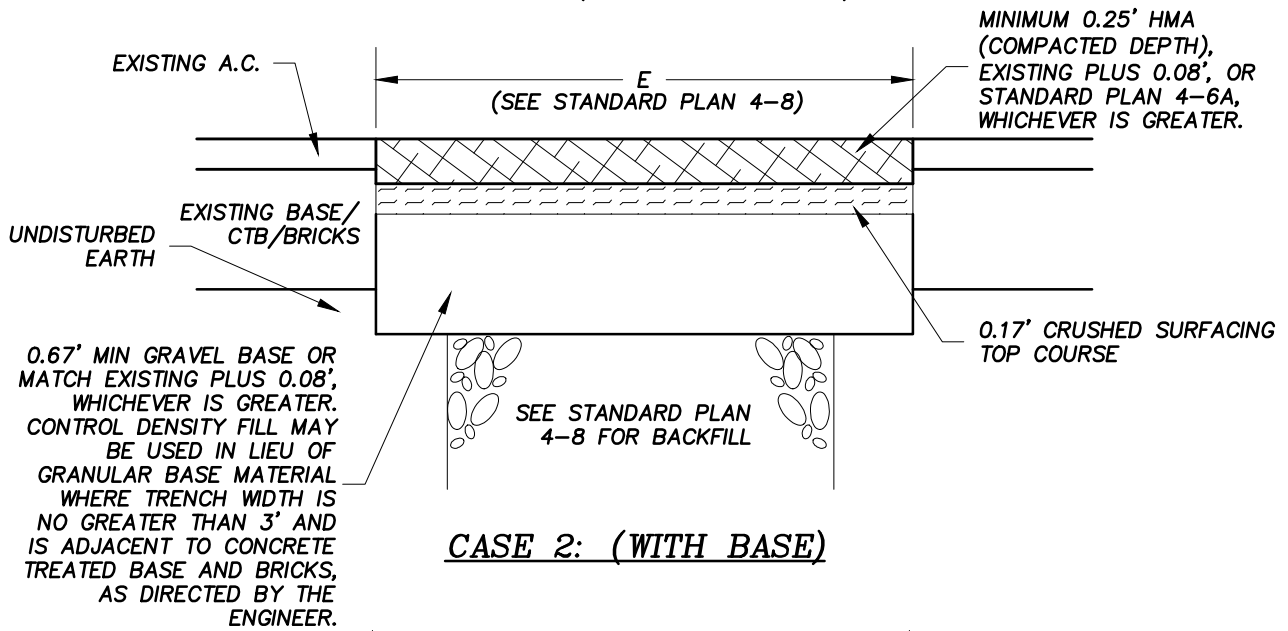

CASE 2: (WITH BASE)

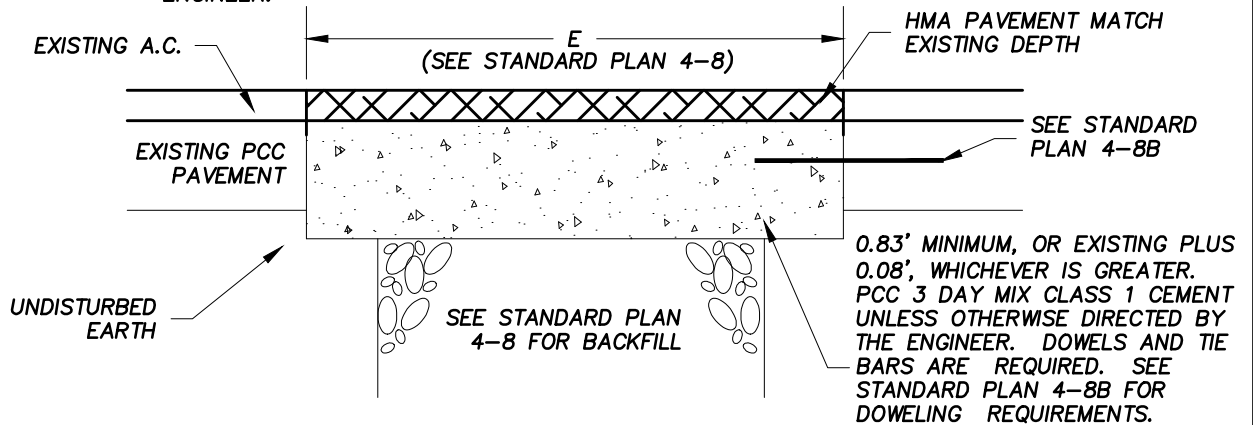

CASE 3: (WITH AC PAVEMENT ON PCC PAVEMENT)

NOTE CASE 1,2,3:
WHEN CUT LINE IS LESS THAN THREE FEET FROM A CUT LINE, CURB OR PAVEMENT EDGE,
THE EXISTING PAVEMENT SHALL BE REMOVED TO THE CUT LINES.

APPROVED BY	REVISED DATE	CITY OF OLYMPIA PAVEMENT REPLACEMENT	STD. PLAN NO.
CITY ENGINEER	4/23/08		4-8A

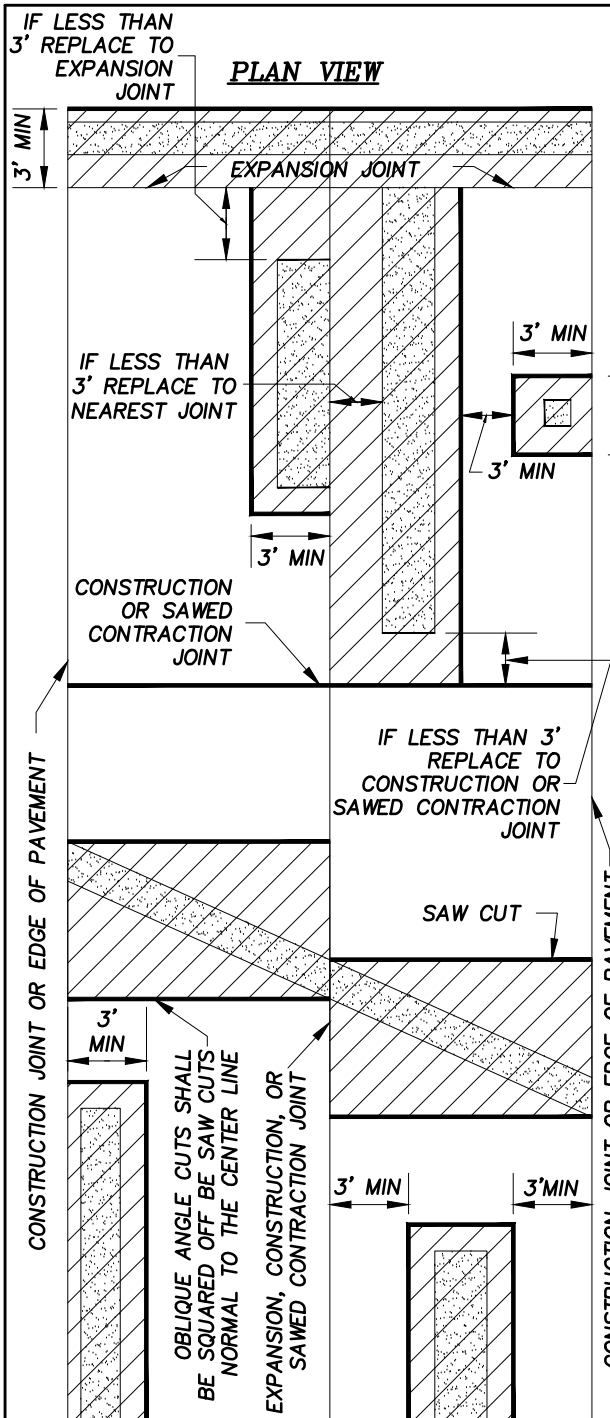

NOTES

1. THE EXTENT OF REPAIR OF CONCRETE CUTS NOT SHOWN ON THIS STANDARD OR FOR CUTS MADE WITHIN THREE FEET OF EXISTING PATCHES, CRACKS OR DETERIORATED SLABS SHALL BE DETERMINED BY THE ENGINEER.
2. ALL TRANSVERSE AND LONGITUDINAL JOINTS AND OUTER EDGES OF THE PAVEMENT WHICH ARE PART OF THE REPLACED CONCRETE SHALL BE EDGED WITH AN EDGING TOOL HAVING A RADIUS OF 0.25 INCH.
3. REPLACED CONCRETE THAT JOINS A SAWED EDGE OF THE EXISTING PAVEMENT SHALL NOT BE EDGED.
4. REPLACED CONCRETE SHALL BE FINISHED TO THE SAME SURFACE TEXTURE AS THAT OF ADJACENT EXISTING CONCRETE.
5. ALL PAVEMENT REMOVALS SHALL BE MADE ON STRAIGHT LINE SAW CUTS A MINIMUM OF 1.5 INCHES DEEP. IF CUT LINE IS LESS THAN THREE FEET FROM A CUT LINE, EXPANSION JOINT OR EDGE, THE EXISTING PAVEMENT SHALL BE REMOVED TO THOSE CUT LINES, EXPANSION JOINT OR EDGE OR AS DIRECTED BY THE ENGINEER.
6. DURING EXCAVATION AND SUBGRADE PREPARATION, THE CONTRACTOR SHALL TAKE ALL NECESSARY STEPS TO INSURE THE PROTECTION OF ALL UTILITIES AND ADJACENT PAVEMENT SECTIONS.
7. TIE BARS AND DOWELS PER WSDOT STANDARD SPECIFICATIONS 5-05.3(10).
8. JOINTS PER WSDOT STANDARD SPECIFICATION 5-05.3(8).

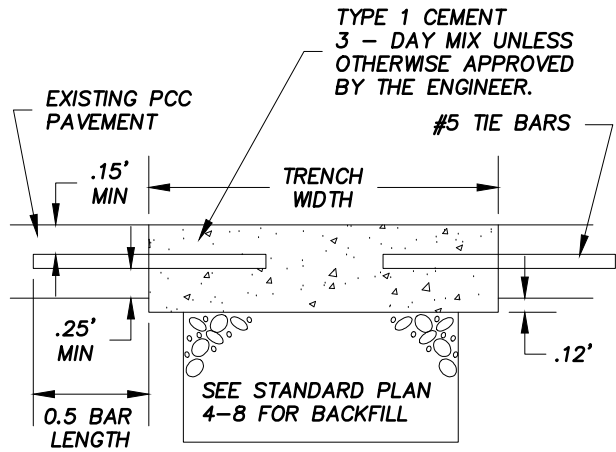

REPLACEMENT SECTION

LEGEND

- EXCAVATION
- AREA OF CONCRETE PAVEMENT TO BE REPLACED

CEMENT CONCRETE REPLACEMENT WIDTH	DOWEL BAR LENGTH	SPACING
4' OR LESS	16 INCHES	18 INCH CENTERS
4' TO 6'	24 INCHES	18 INCH CENTERS
6' OR GREATER	30 INCHES	18 INCH CENTERS

APPROVED BY	REVISED DATE	CITY OF OLYMPIA CONCRETE PAVEMENT REPLACEMENT	STD. PLAN NO.
CITY ENGINEER	11/1/04		4-8B

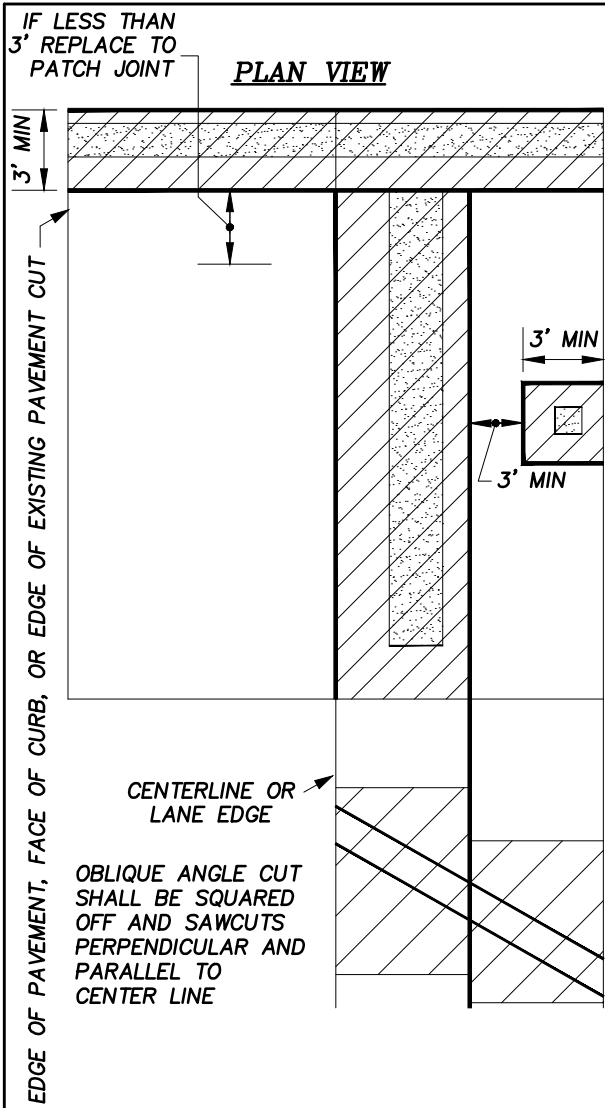

NOTES

1. THE EXTENT OF REPAIR OF ASPHALT CUTS NOT SHOWN ON THIS STANDARD OR FOR CUTS MADE WITHIN THREE FEET OF EXISTING PATCHES, CRACKS OR DETERIORATED PAVEMENTS SHALL BE DETERMINED BY THE ENGINEER AND PERFORMED PER THE SUBMITTED RESTORATION/PAVEMENT DESIGN.

2. ALL PAVEMENT REMOVALS SHALL BE MADE ON STRAIGHT LINE SAW CUTS. IF CUT LINE IS LESS THAN THREE FEET FROM A CUT LINE, EXPANSION JOINT OR EDGE, THE EXISTING PAVEMENT SHALL BE REMOVED TO THOSE CUT LINES, EXPANSION JOINT OR EDGE OR AS DIRECTED BY THE ENGINEER.

3. DURING EXCAVATION AND SUBGRADE PREPARATION, THE CONTRACTOR SHALL TAKE ALL NECESSARY STEPS TO INSURE THE PROTECTION OF ALL UTILITIES AND ADJACENT PAVEMENT SECTIONS.

LEGEND

- EXCAVATION
- AREA OF PAVEMENT TO BE REPLACED
- SAW CUT

4. AC PATCH SHALL BE A MINIMUM OF 4" OR AS DIRECTED BY THE ENGINEER. (EXCLUDING OVERLAY)

5. GRIND 2" MINIMUM OF ONE LANE WIDTH. SEE TABLE III (PAVEMENT RESTORATION REQUIREMENTS, PAGE 4-26 FOR ADDITIONAL RESTORATION REQUIREMENTS)

PAVEMENT CROSS SECTION

END OF PAVING
GRINDING DETAIL

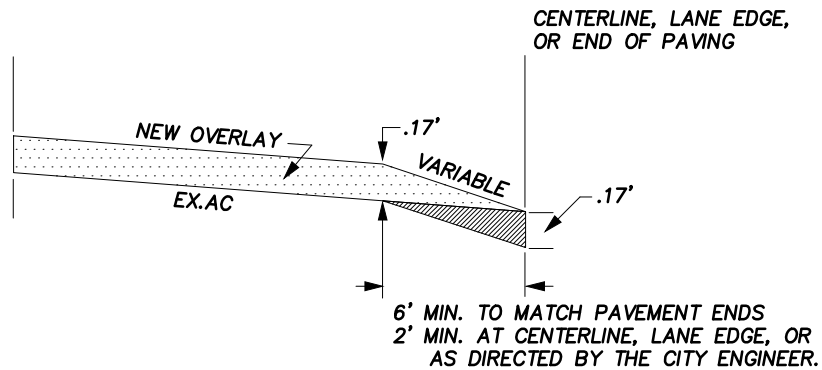

APPROVED BY	REVISED DATE	CITY OF OLYMPIA ASPHALT PAVEMENT RESTORATION	STD. PLAN NO.
CITY ENGINEER	12/03/07		4-8C

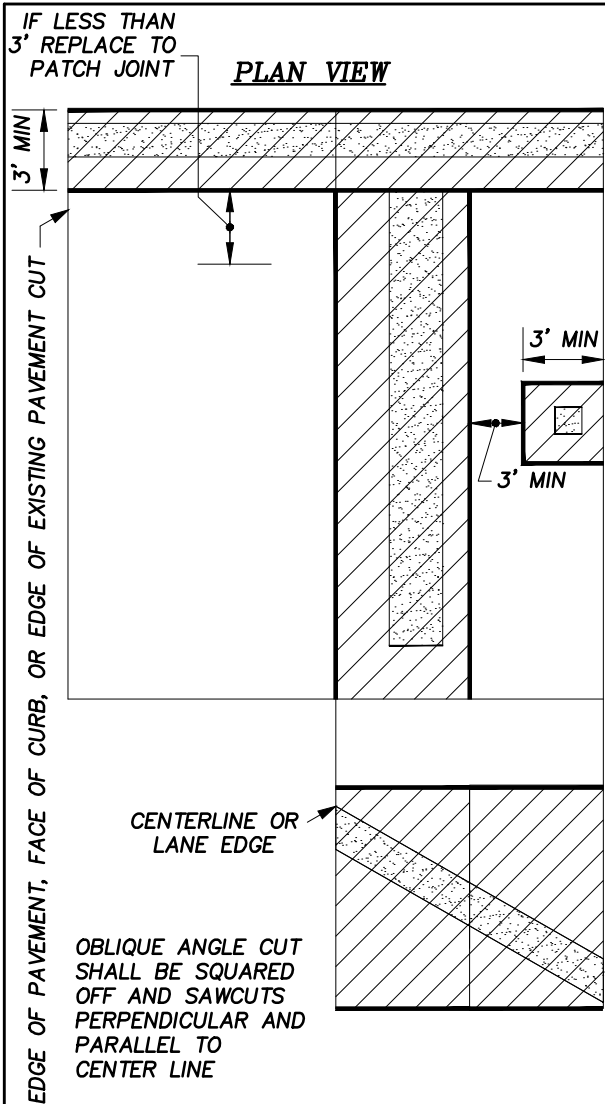

NOTES

1. THE EXTENT OF REPAIR OF ASPHALT CUTS NOT SHOWN ON THIS STANDARD OR FOR CUTS MADE WITHIN THREE FEET OF EXISTING PATCHES, CRACKS OR DETERIORATED PAVEMENTS SHALL BE DETERMINED BY THE ENGINEER AND PERFORMED PER THE SUBMITTED RESTORATION/PAVEMENT DESIGN.

2. ALL PAVEMENT REMOVALS SHALL BE MADE ON STRAIGHT LINE SAW CUTS. IF CUT LINE IS LESS THAN THREE FEET FROM A CUT LINE, EXPANSION JOINT OR EDGE, THE EXISTING PAVEMENT SHALL BE REMOVED TO THOSE CUT LINES, EXPANSION JOINT OR EDGE OR AS DIRECTED BY THE ENGINEER.

3. DURING EXCAVATION AND SUBGRADE PREPARATION, THE CONTRACTOR SHALL TAKE ALL NECESSARY STEPS TO INSURE THE PROTECTION OF ALL UTILITIES AND ADJACENT PAVEMENT SECTIONS.

LEGEND

- EXCAVATION
- AREA OF PAVEMENT TO BE REPLACED
- SAW CUT

4. AC PATCH SHALL BE A MINIMUM OF 4" OR AS DIRECTED BY THE ENGINEER. (EXCLUDING OVERLAY)

5. GRIND 2" MINIMUM OF ONE LANE WIDTH. SEE TABLE III (PAVEMENT RESTORATION REQUIREMENTS, PAGE 4-26 FOR ADDITIONAL RESTORATION REQUIREMENTS)

PAVEMENT CROSS SECTION

END OF PAVING GRINDING DETAIL

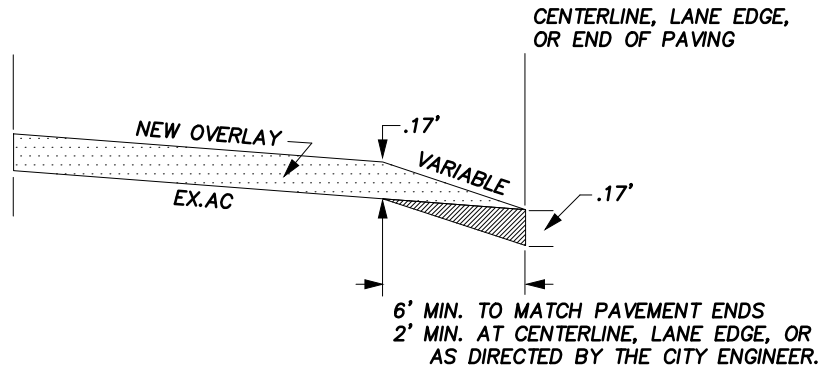

APPROVED BY	REVISED DATE	CITY OF OLYMPIA ASPHALT PAVEMENT RESTORATION	STD. PLAN NO.
CITY ENGINEER	12/03/07		4-8C

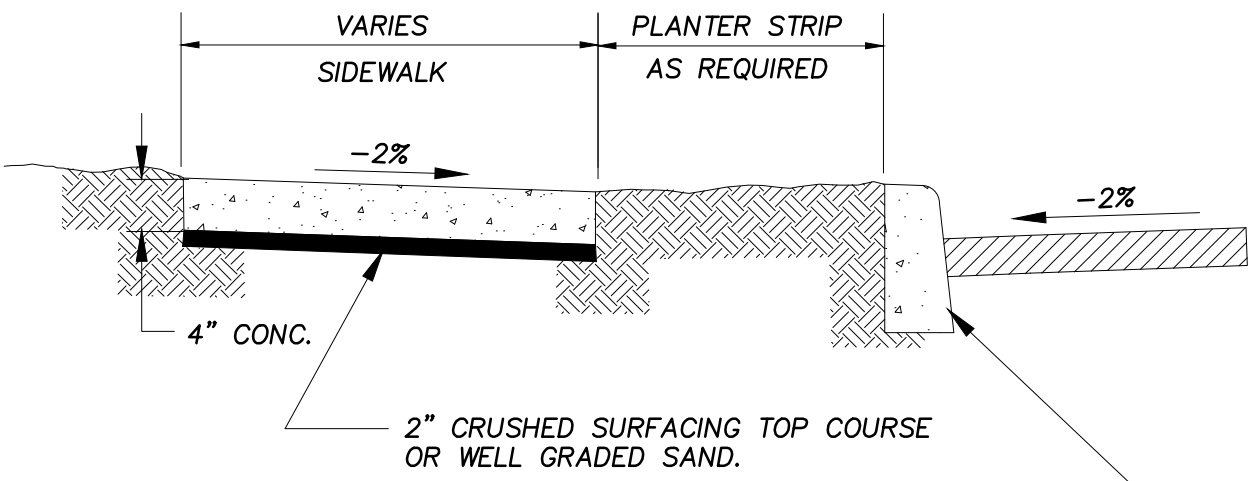
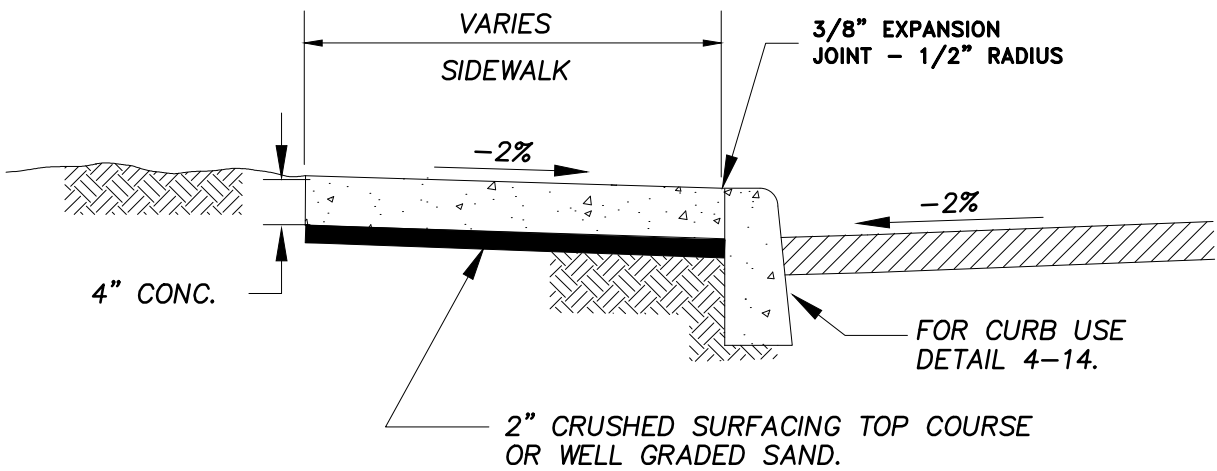

GENERAL NOTES:

1. FOR JOINTS AND SCORING, SEE OLYMPIA STANDARD 4-10
2. CONCRETE DRIVEWAYS REQUIRE A MINIMUM DEPTH OF 6".
3. WHEN CHECKED WITH A 10 FOOT STRAIGHTEDGE, GRADE SHALL NOT DEVIATE MORE THAN 1/8 INCH, AND ALIGNMENT SHALL NOT VARY MORE THAN 1/4 INCH.

APPROVED BY	REVISED DATE	CITY OF OLYMPIA	STD. PLAN NO.
	2/22/08	SIDEWALK	4-9
CITY ENGINEER			

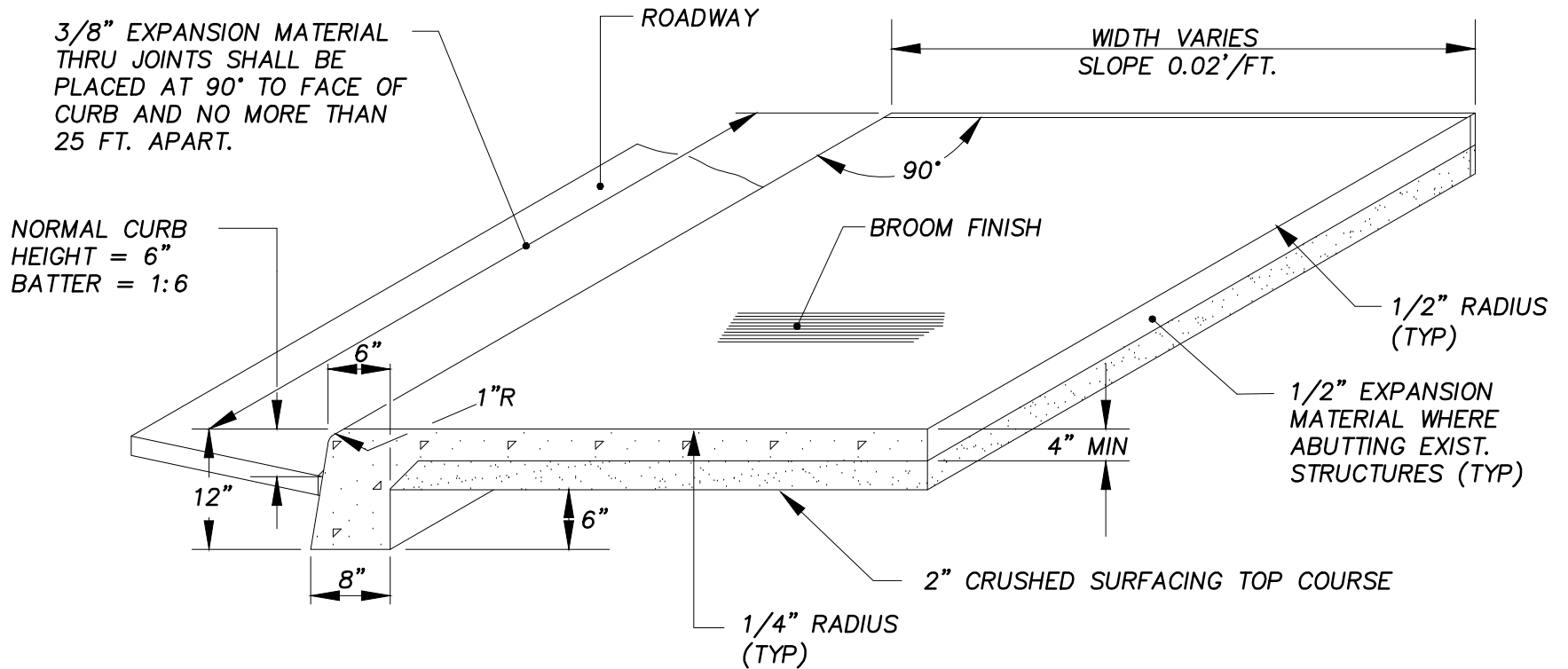

NOTES:

- FORM AND SUBGRADE INSPECTION REQUIRED BEFORE POURING.
- CONCRETE SHALL BE TYPE II PORTLAND CEMENT CLASS 3000.
- BROOM FINISH SHALL BE PERPENDICULAR TO FACE OF CURB.
- JOINTS SHALL BE TROWEL FINISHED, AFTER BROOMING.
- INTEGRAL CURB AND WALK SHALL BE USED ONLY IN ("IN-FILL") TYPE SITUATIONS WHERE NEEDED TO MATCH EXISTING IMPROVEMENTS.
- ALL EDGES AND JOINTS SHALL BE FINISHED.
- WHEN CHECKED WITH A 10 FOOT STRAIGHTEDGE, GRADE SHALL NOT DEVIATE MORE THAN 1/8 INCH, AND ALIGNMENT SHALL NOT VARY MORE THAN 1/4 INCH.

APPROVED BY	REVISED DATE	CITY OF OLYMPIA	STD. PLAN NO.
	11/1/96	CEMENT CONCRETE INTEGRAL CURB & WALK TYPE "A"	4-9A
CITY ENGINEER			

SECTION A-A

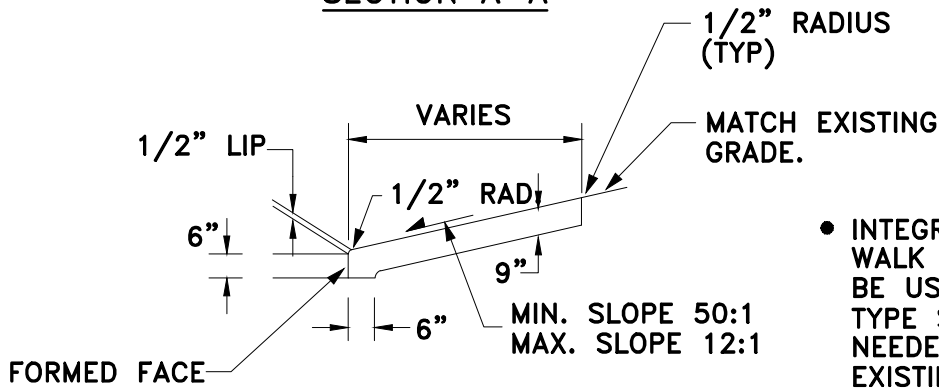

- INTEGRAL CURB AND WALK DRIVEWAY SHALL BE USED ONLY IN "IN-FILL" TYPE SITUATIONS WHERE NEEDED TO MATCH EXISTING INTEGRAL CURB AND WALK.

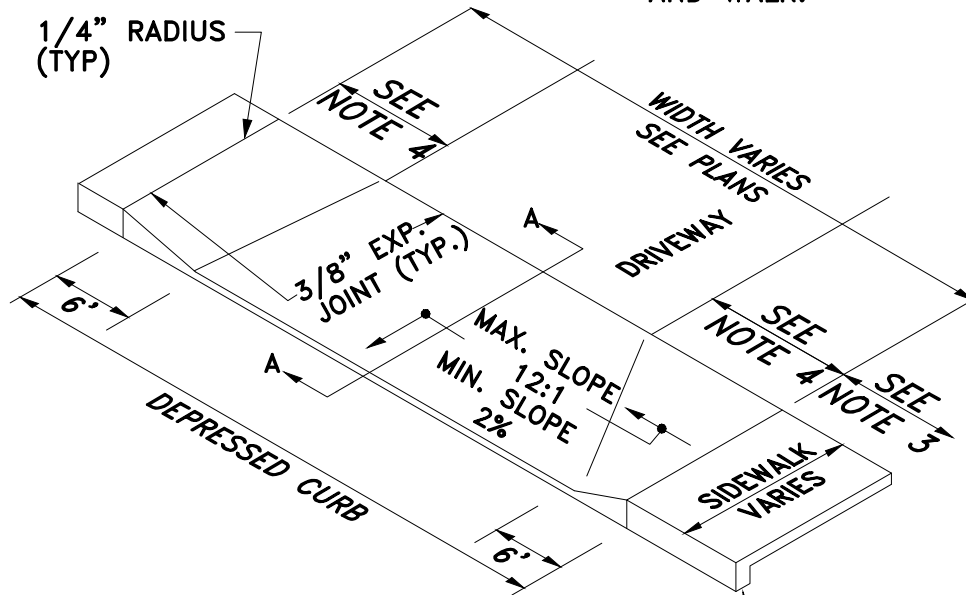

CEMENT CONCRETE INTEGRAL CURB & WALK. (SEE STD PLAN 4-9A)

NOTES:

1. WHERE D/W EXCEEDS 16' WIDTH AN EXPANSION JOINT SHALL BE PLACED TRANSVERSLY, CENTERED IN DRIVEWAY.
2. EXPANSION JOINT MATERIAL TO BE 3/8" THICK PREMOLDED JOINT FILLER FULL THICKNESS,
3. FORM AND SUBGRADE INSPECTION ARE REQUIRED BEFORE PLACING CONCRETE.
4. TRANSITION WIDTH WILL VARY DEPENDING ON DRIVEWAY SLOPE. MAINTAIN 12:1 TRANSITION SLOPE
5. 6' MIN. SPACING REQUIRED TO NEXT DRIVEWAY.
6. DRIVEWAY WIDTH AT THE THROAT SHALL NOT EXCEED 11' WIDE IN CUL-DE-SACS.
7. BROOM FINISH LONGITUDINALLY WITH LIGHT BROOM FINISH INCLUDING CURB FACE.
8. WHEN CHECKED WITH A 10 FOOT STRAIGHTEDGE, GRADE SHALL NOT DEVIATE MORE THAN 1/8 INCH, AND ALIGNMENT SHALL NOT VARY MORE THAN 1/4 INCH.

APPROVED BY	REVISED DATE	CITY OF OLYMPIA	STD. PLAN NO.
	12/03/07	CEMENT CONCRETE INTEGRAL CURB & WALK DRIVEWAY	4-9B
CITY ENGINEER			

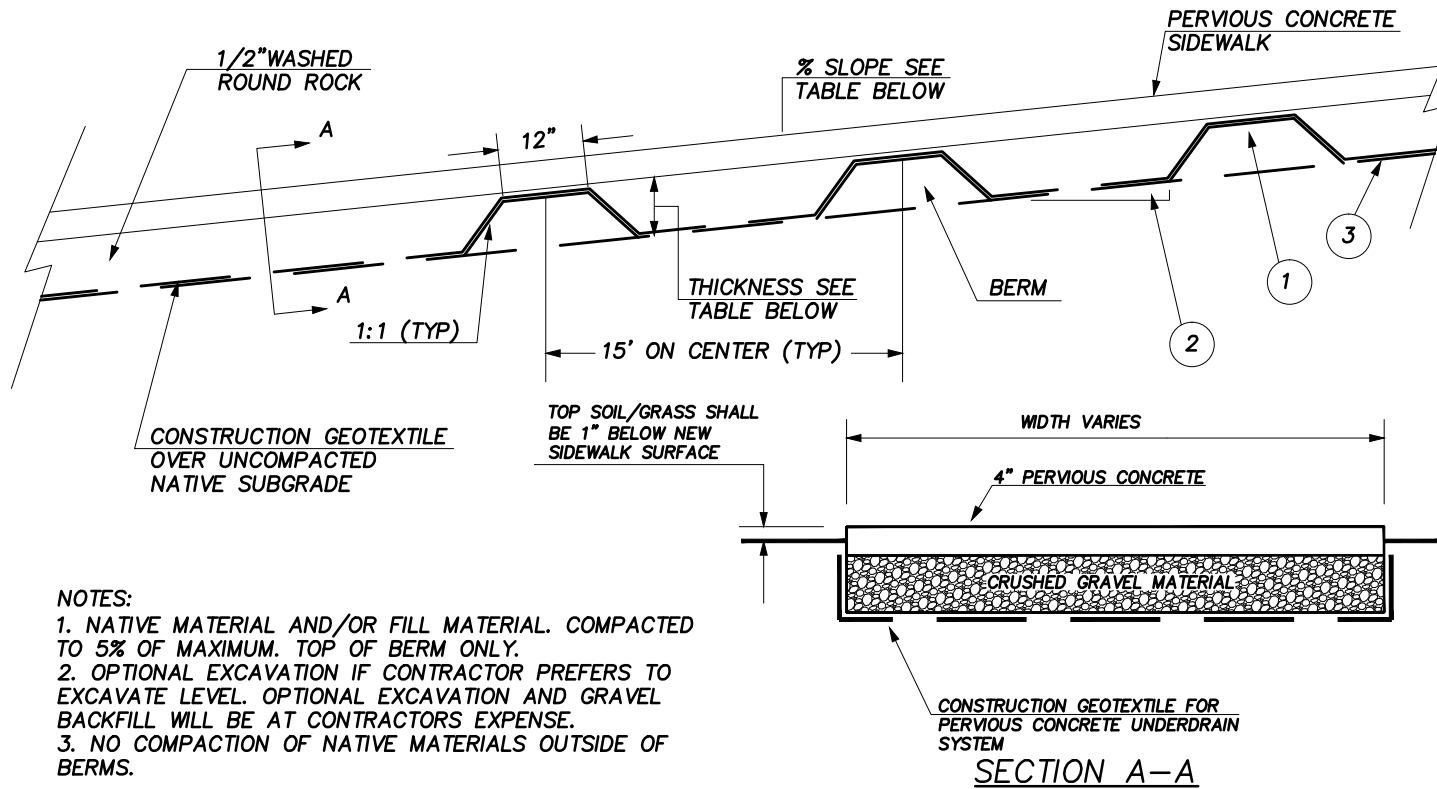

- NOTES:
1. NATIVE MATERIAL AND/OR FILL MATERIAL. COMPACTED TO 5% OF MAXIMUM. TOP OF BERM ONLY.
 2. OPTIONAL EXCAVATION IF CONTRACTOR PREFERS TO EXCAVATE LEVEL. OPTIONAL EXCAVATION AND GRAVEL BACKFILL WILL BE AT CONTRACTORS EXPENSE.
 3. NO COMPACTION OF NATIVE MATERIALS OUTSIDE OF BERMS.

GRAVEL BACKFILL THICKNESS		
% SLOPE	% SLOPE RANGE	THICKNESS *
0	0 - 0.5	7.0'
1	0.5 - 1.5	8.0'
2	1.5 - 2.5	9.0'
3	2.5 - 3.5	9.5'
4	3.5 - 4.5	10.5'
5	4.5 - 5.5	11.5'
6	5.5 - 6.5	12.0'
7	6.5 - 7.5	13.0'
8	7.5 - 8.5	14.0'
9	8.5 - 9.5	15.0'

APPROVED BY	REVISED DATE	CITY OF OLYMPIA	STD. PLAN NO.
	5/29/2009	PERVIOUS CONCRETE UNDERDRAIN SYSTEM	4-9C
CITY ENGINEER			

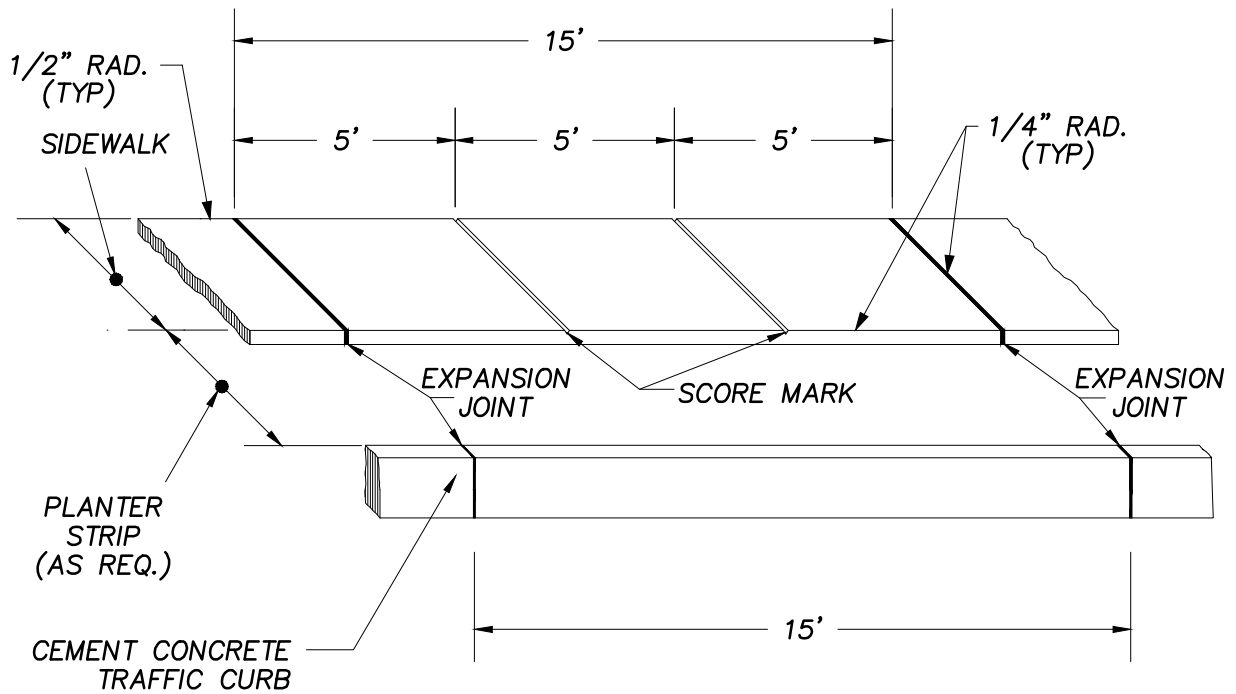

GENERAL NOTES:

1. EXPANSION JOINT MATERIAL TO BE 3/8" THICK PREMOLDED JOINT FILLER FULL THICKNESS OF CONCRETE.
2. FORM AND SUBGRADE INSPECTION REQUIRED BEFORE POURING CONCRETE.
3. SCORE MARKS SHALL BE ±1/8" WIDE BY ±1/4" DEEP. FOR SIDEWALKS OVER 8' IN WIDTH, A LONGITUDINAL SCORE MARK SHALL BE MADE ALONG CENTER OF WALK.
4. EXPANSION JOINTS SHALL BE INSTALLED IN CURB AND GUTTER AND IN SIDEWALK AT PC AND PT AT ALL CURB RETURNS. EXPANSION JOINTS SHALL BE PLACED IN SIDEWALK AT SAME LOCATIONS AS IN CURB AND GUTTER WHEN SIDEWALK IS ADJACENT TO CURB AND GUTTER, UNLESS OTHERWISE DIRECTED BY ENGINEER.

APPROVED BY	REVISED DATE	CITY OF OLYMPIA	STD. PLAN NO.
	2/22/08	SIDEWALK SPACING	4-10
CITY ENGINEER		EXPANSION JOINTS & SCORE MARKS	

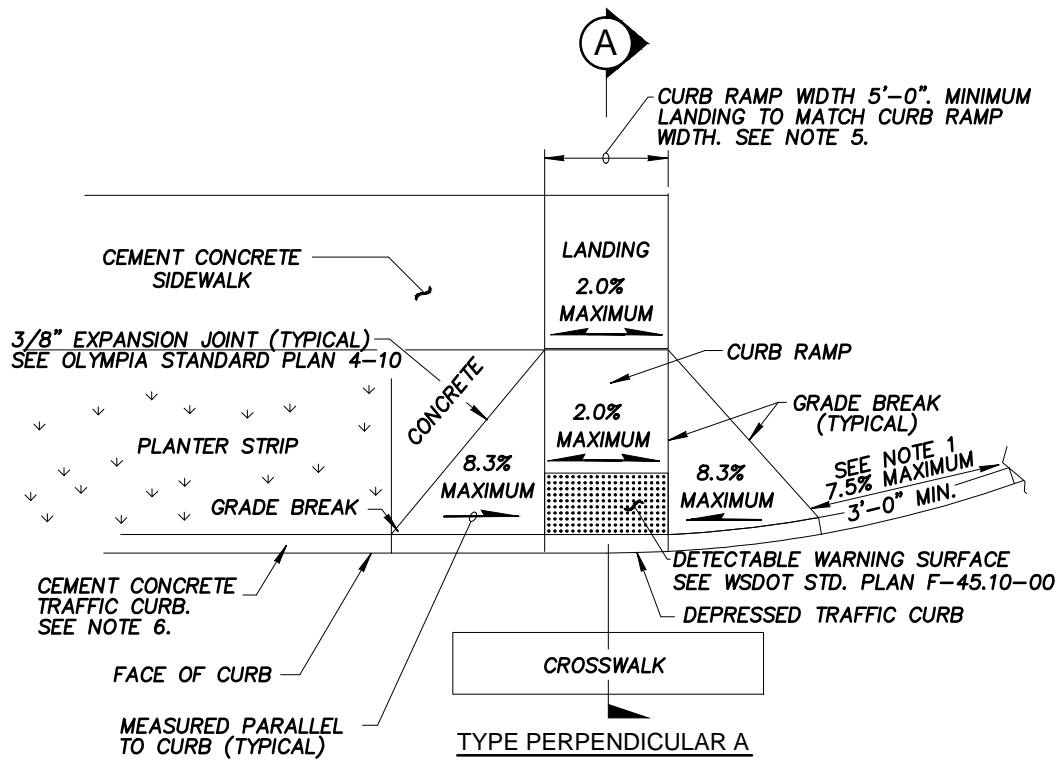

NOTES:

1. IT IS THE INTENT OF THE ENGINEERING DESIGN AND DEVELOPMENT STANDARDS TO HAVE CONSTRUCTED ACCESS RAMPS THAT MINIMIZE PEDESTRIAN CROSSING DISTANCES, AND POSITION PEDESTRIANS WHERE THEY CAN BEST BE SEEN BY ONCOMING TRAFFIC. CURB RAMP ORIENTATION WILL ALIGN PEDESTRIANS PARALLEL WITHIN THE LATERAL EXTENSION LINES OF THE SIDEWALK. INTERSECTION RADIUS LESS THAN 35' WILL USE TWO PERPENDICULAR CURB ACCESS RAMPS PER CORNER. WHERE INTERSECTION CORNERS ARE OFF-SET, CURB ACCESS RAMPS WILL ORIENTATE DIAGONALLY TO THE OPPOSING CURB ACCESS RAMP. LANDING BETWEEN ACCESS RAMPS WILL NOT BE LESS THAN 5' WITH A SLOPE NO GREATER THAN 2.0%. CENTER AND DIRECTION OF RAMP SHALL BE LOCATED WITHIN CROSSWALK LINES AS CLOSE AND PARALLEL TO CROSSWALK CENTERLINE AS POSSIBLE. SEE OLYMPIA STANDARD PLAN 4-32.
2. GRADE BREAKS AT THE TOP AND BOTTOM OF THE CURB RAMP WILL BE PERPENDICULAR TO THE DIRECTION OF THE RAMP. ANY TRIANGLE LANDING BETWEEN THE GRADE BREAK AND THE CURB WILL BE 2.0% MAXIMUM SLOPE. THE ENTIRE LENGTH OF THE GRADE BREAK BETWEEN THE TWO ADJACENT SURFACE PLANES SHALL BE FLUSH.
3. PLACED JUNCTION BOXES, ACCESS COVERS, OR OTHER APPURTENANCES IN CURB RAMP SHALL BE ADA COMPLIANT. DO NOT PLACE GRATING IN FRONT OF OR IN ANY PART OF THE CURB RAMP OR LANDING.
4. CURB RAMP LANDING, AND FLARES SHALL RECEIVE BROOM FINISH. SEE WSDOT STANDARD SPECIFICATIONS 8-14.
5. CURB RAMP WIDTH AND LANDINGS MAY BE REDUCED TO 4'-0" WITH APPROVAL FROM CITY ENGINEER.
6. USE OLYMPIA STANDARD PLAN 4-14 WHEN BICYCLE LANE IS PRESENT OR PLANNED OR OLYMPIA STANDARD PLAN 4-14A WHEN BICYCLE LANE IS NOT PRESENT OR PLANNED.
7. THE CURB RAMP MAXIMUM RUNNING SLOPE SHALL NOT REQUIRE THE RAMP LENGTH TO EXCEED 15 FEET TO AVOID CHASING THE SLOPE INDEFINITELY WHEN CONNECTING TO STEEP GRADES. WHEN APPLYING THE 15 FOOT MAXIMUM LENGTH THE RUNNING SLOPE OF THE CURB RAMP SHALL BE AS FLAT AS FEASIBLE. CURB RAMP SLOPE INCLUDING TOLERANCE NOT TO EXCEED 8.3%.

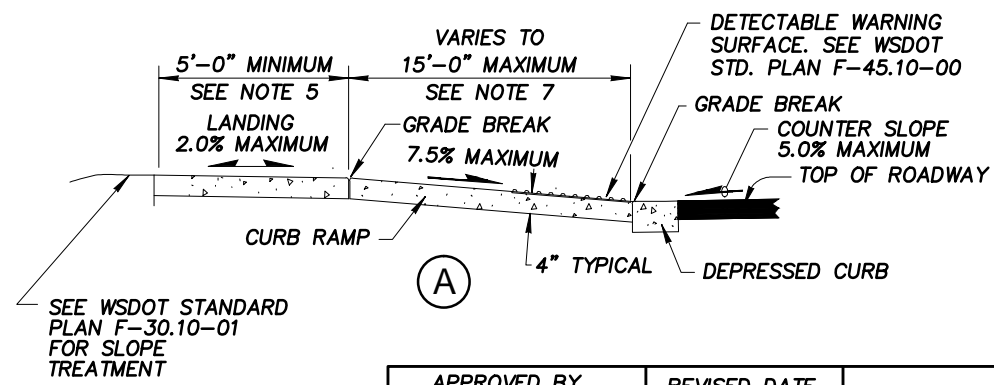

LEGEND

 SLOPE IN EITHER DIRECTION

APPROVED BY	REVISED DATE	CITY OF OLYMPIA PERPENDICULAR CURB RAMP TYPE A	STD. PLAN NO.
CITY ENGINEER	NEW		4-12A

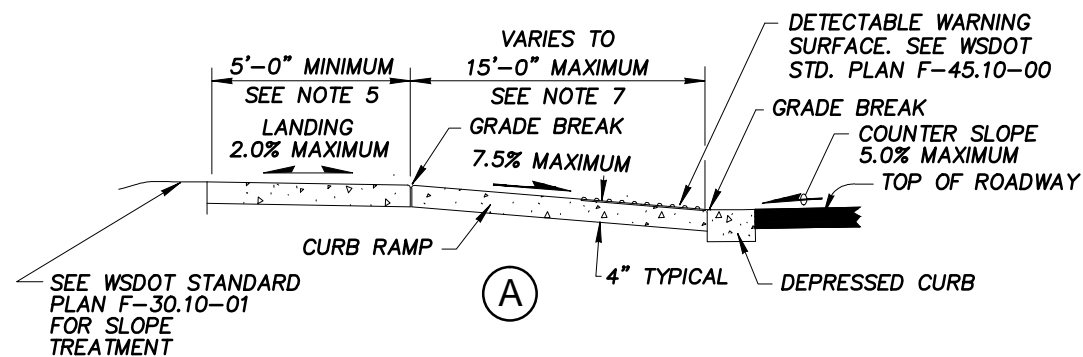
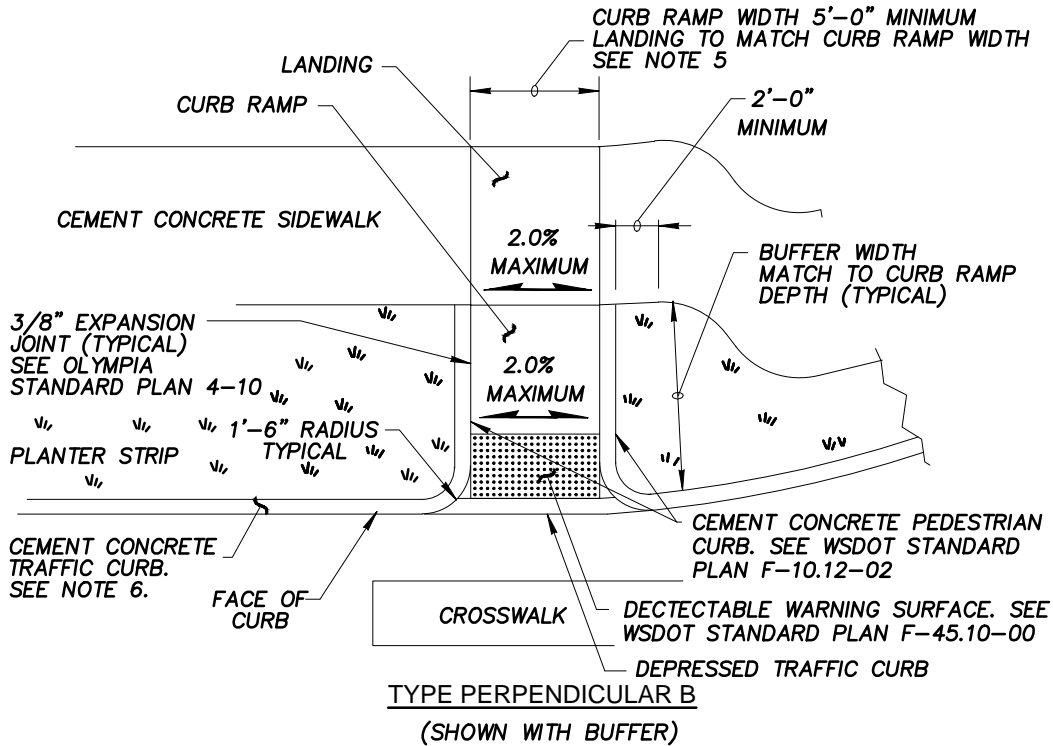

LEGEND
 SLOPE IN EITHER DIRECTION

APPROVED BY	REVISED DATE	CITY OF OLYMPIA PERPENDICULAR CURB RAMP TYPE B (SHOWN WITH BUFFER)	STD. PLAN NO.
CITY ENGINEER	NEW		4-12B

NOTES:

- IT IS THE INTENT OF THE ENGINEERING DESIGN AND DEVELOPMENT STANDARDS TO HAVE CONSTRUCTED ACCESS RAMPS THAT MINIMIZE PEDESTRIAN CROSSING DISTANCES, AND POSITION PEDESTRIANS WHERE THEY CAN BEST BE SEEN BY ONCOMING TRAFFIC. CURB RAMP ORIENTATION WILL ALIGN PEDESTRIANS PARALLEL WITHIN THE LATERAL EXTENSION LINES OF THE SIDEWALK. INTERSECTION RADIUS LESS THAN 35' WILL USE TWO PERPENDICULAR CURB ACCESS RAMPS PER CORNER. WHERE INTERSECTION CORNERS ARE OFF-SET, CURB ACCESS RAMPS WILL ORIENTATE DIAGONALLY TO THE OPPOSING CURB ACCESS RAMP. LANDING BETWEEN ACCESS RAMPS WILL NOT BE LESS THAN 5' WITH A SLOPE NO GREATER THAN 2.0%. CENTER AND DIRECTION OF RAMP SHALL BE LOCATED WITHIN CROSSWALK LINES AS CLOSE AND PARALLEL TO CROSSWALK CENTERLINE AS POSSIBLE. SEE OLYMPIA STANDARD PLAN 4-32.
- GRADE BREAKS AT THE TOP AND BOTTOM OF THE CURB RAMP WILL BE PERPENDICULAR TO THE DIRECTION OF THE RAMP. ANY TRIANGLE LANDING BETWEEN THE GRADE BREAK AND THE CURB WILL BE 2.0% MAXIMUM SLOPE. THE ENTIRE LENGTH OF THE GRADE BREAK BETWEEN THE TWO ADJACENT SURFACE PLANES SHALL BE FLUSH.
- PLACED JUNCTION BOXES, ACCESS COVERS, OR OTHER APPURTENANCES IN CURB RAMP SHALL BE ADA COMPLIANT. DO NOT PLACE GRATING IN FRONT OF OR IN ANY PART OF THE CURB RAMP OR LANDING.
- CURB RAMP LANDING, AND FLARES SHALL RECEIVE BROOM FINISH. SEE WSDOT STANDARD SPECIFICATIONS 8-14.
- CURB RAMP WIDTH AND LANDINGS MAY BE REDUCED TO 4'-0" WITH APPROVAL FROM CITY ENGINEER.
- USE OLYMPIA STANDARD PLAN 4-14 WHEN BICYCLE LANE IS PRESENT OR PLANNED OR OLYMPIA STANDARD PLAN 4-14A WHEN BICYCLE LANE IS NOT PRESENT OR PLANNED.
- THE CURB RAMP MAXIMUM RUNNING SLOPE SHALL NOT REQUIRE THE RAMP LENGTH TO EXCEED 15 FEET TO AVOID CHASING THE SLOPE INDEFINITELY WHEN CONNECTING TO STEEP GRADES. WHEN APPLYING THE 15 FOOT MAXIMUM LENGTH THE RUNNING SLOPE OF THE CURB RAMP SHALL BE AS FLAT AS FEASIBLE. CURB RAMP SLOPE INCLUDING TOLERANCE NOT TO EXCEED 8.3%.

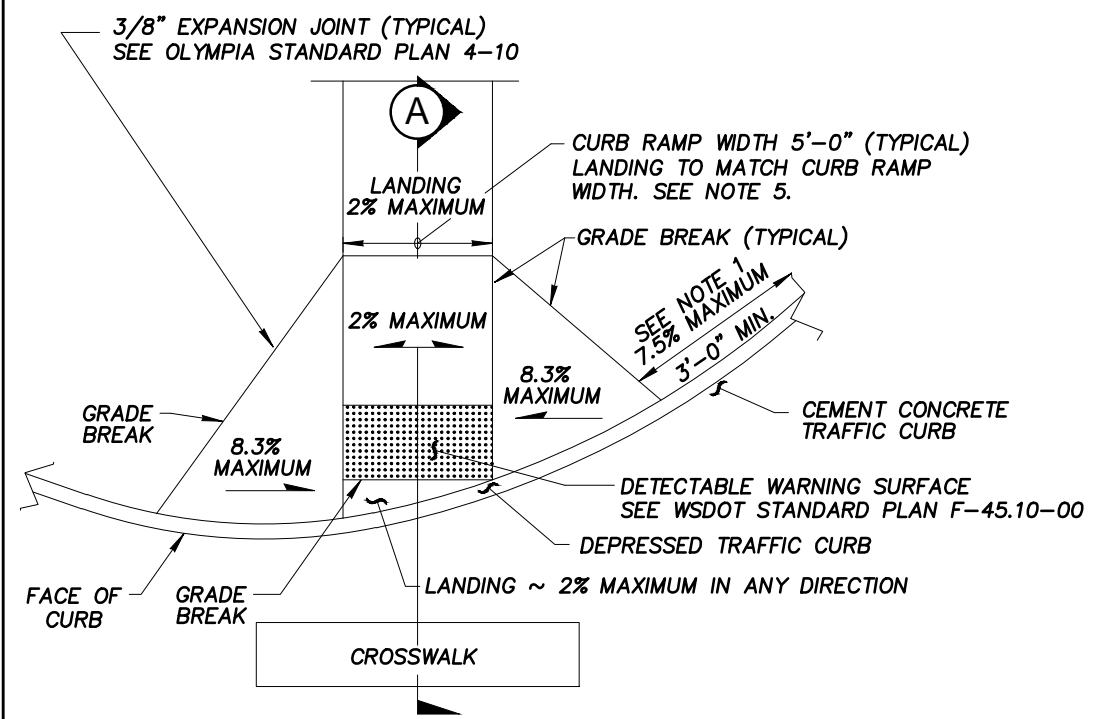

TYPE PERPENDICULAR C

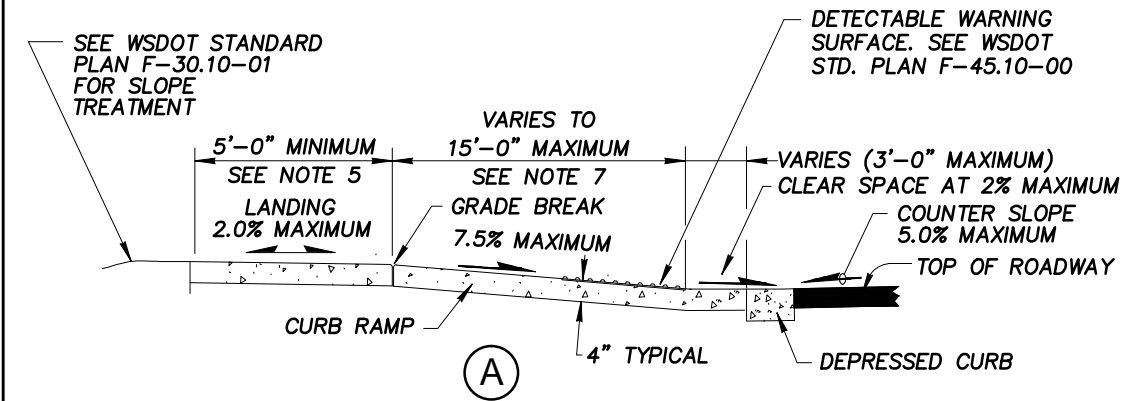

LEGEND

SLOPE IN EITHER DIRECTION

NOTES:

1. IT IS THE INTENT OF THE ENGINEERING DESIGN AND DEVELOPMENT STANDARDS TO HAVE CONSTRUCTED ACCESS RAMPS THAT MINIMIZE PEDESTRIAN CROSSING DISTANCES, AND POSITION PEDESTRIANS WHERE THEY CAN BEST BE SEEN BY ONCOMING TRAFFIC. CURB RAMP ORIENTATION WILL ALIGN PEDESTRIANS PARALLEL WITHIN THE LATERAL EXTENSION LINES OF THE SIDEWALK. INTERSECTION RADIUS LESS THAN 35' WILL USE TWO PERPENDICULAR CURB ACCESS RAMPS PER CORNER. WHERE INTERSECTION CORNERS ARE OFF-SET, CURB ACCESS RAMPS WILL ORIENTATE DIAGONALLY TO THE OPPOSING CURB ACCESS RAMP. LANDING BETWEEN ACCESS RAMPS WILL NOT BE LESS THAN 5' WITH A SLOPE NO GREATER THAN 2.0%. CENTER AND DIRECTION OF RAMP SHALL BE LOCATED WITHIN CROSSWALK LINES AS CLOSE AND PARALLEL TO CROSSWALK CENTERLINE AS POSSIBLE. SEE OLYMPIA STANDARD PLAN 4-32.
2. GRADE BREAKS AT THE TOP AND BOTTOM OF THE CURB RAMP WILL BE PERPENDICULAR TO THE DIRECTION OF THE RAMP. ANY TRIANGLE LANDING BETWEEN THE GRADE BREAK AND THE CURB WILL BE 2.0% MAXIMUM SLOPE. THE ENTIRE LENGTH OF THE GRADE BREAK BETWEEN THE TWO ADJACENT SURFACE PLANES SHALL BE FLUSH.
3. PLACED JUNCTION BOXES, ACCESS COVERS, OR OTHER APPURTENANCES IN CURB RAMP SHALL BE ADA COMPLIANT. DO NOT PLACE GRATING IN FRONT OF OR IN ANY PART OF THE CURB RAMP OR LANDING.
4. CURB RAMP LANDING, AND FLARES SHALL RECEIVE BROOM FINISH. SEE WSDOT STANDARD SPECIFICATIONS 8-14.
5. CURB RAMP WIDTH AND LANDINGS MAY BE REDUCED TO 4'-0" WITH APPROVAL FROM CITY ENGINEER.
6. USE OLYMPIA STANDARD PLAN 4-14 WHEN BICYCLE LANE IS PRESENT OR PLANNED OR OLYMPIA STANDARD PLAN 4-14A WHEN BICYCLE LANE IS NOT PRESENT OR PLANNED.
7. THE CURB RAMP MAXIMUM RUNNING SLOPE SHALL NOT REQUIRE THE RAMP LENGTH TO EXCEED 15 FEET TO AVOID CHASING THE SLOPE INDEFINITELY WHEN CONNECTING TO STEEP GRADES. WHEN APPLYING THE 15 FOOT MAXIMUM LENGTH THE RUNNING SLOPE OF THE CURB RAMP SHALL BE AS FLAT AS FEASIBLE. CURB RAMP SLOPE INCLUDING TOLERANCE NOT TO EXCEED 8.3%.

APPROVED BY	REVISED DATE	CITY OF OLYMPIA	STD. PLAN NO.
	DATE		
CITY ENGINEER		PERPENDICULAR CURB RAMP TYPE C	4-12C

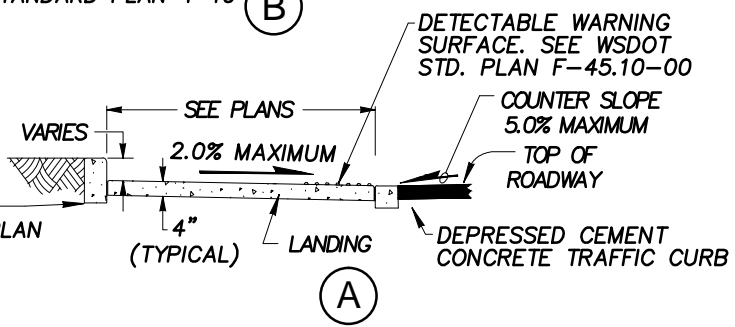
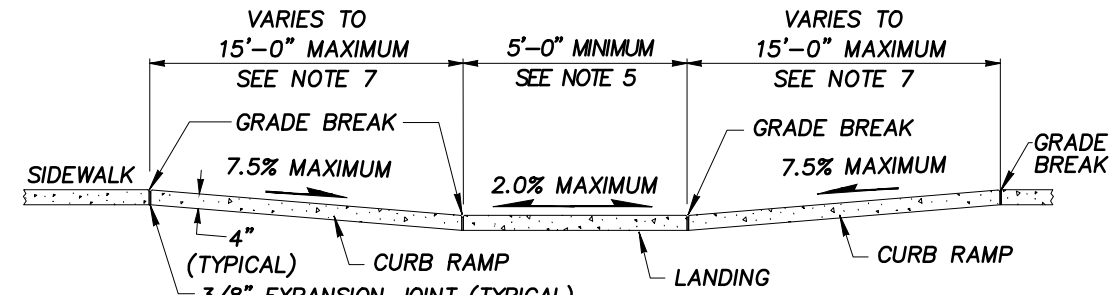
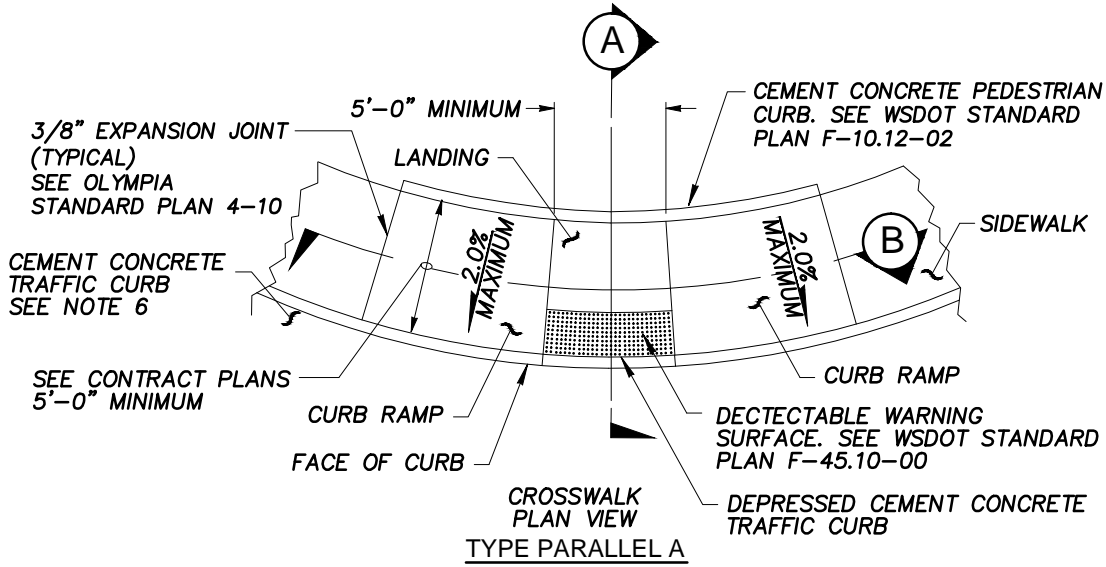

NOTES:

1. IT IS THE INTENT OF THE ENGINEERING DESIGN AND DEVELOPMENT STANDARDS TO HAVE CONSTRUCTED ACCESS RAMPS THAT MINIMIZE PEDESTRIAN CROSSING DISTANCES, AND POSITION PEDESTRIANS WHERE THEY CAN BEST BE SEEN BY ONCOMING TRAFFIC. CURB RAMP ORIENTATION WILL ALIGN PEDESTRIANS PARALLEL WITHIN THE LATERAL EXTENSION LINES OF THE SIDEWALK. INTERSECTION RADIUS LESS THAN 35' WILL USE TWO PERPENDICULAR CURB ACCESS RAMPS PER CORNER. WHERE INTERSECTION CORNERS ARE OFF-SET, CURB ACCESS RAMPS WILL ORIENTATE DIAGONALLY TO THE OPPOSING CURB ACCESS RAMP. LANDING BETWEEN ACCESS RAMPS WILL NOT BE LESS THAN 5' WITH A SLOPE NO GREATER THAN 2.0%. CENTER AND DIRECTION OF RAMP SHALL BE LOCATED WITHIN CROSSWALK LINES AS CLOSE AND PARALLEL TO CROSSWALK CENTERLINE AS POSSIBLE. SEE OLYMPIA STANDARD PLAN 4-32.
2. GRADE BREAKS AT THE TOP AND BOTTOM OF THE CURB RAMP WILL BE PERPENDICULAR TO THE DIRECTION OF THE RAMP. ANY TRIANGLE LANDING BETWEEN THE GRADE BREAK AND THE CURB WILL BE 2.0% MAXIMUM SLOPE. THE ENTIRE LENGTH OF THE GRADE BREAK BETWEEN THE TWO ADJACENT SURFACE PLANES SHALL BE FLUSH.
3. PLACED JUNCTION BOXES, ACCESS COVERS, OR OTHER APPURTENANCES IN CURB RAMP SHALL BE ADA COMPLIANT. DO NOT PLACE GRATING IN FRONT OF OR IN ANY PART OF THE CURB RAMP OR LANDING.
4. CURB RAMP LANDING, AND FLARES SHALL RECEIVE BROOM FINISH. SEE WSDOT STANDARD SPECIFICATIONS 8-14.
5. CURB RAMP WIDTH AND LANDINGS MAY BE REDUCED TO 4'-0" WITH APPROVAL FROM CITY ENGINEER.
6. USE OLYMPIA STANDARD PLAN 4-14 WHEN BICYCLE LANE IS PRESENT OR PLANNED OR OLYMPIA STANDARD PLAN 4-14A WHEN BICYCLE LANE IS NOT PRESENT OR PLANNED.
7. THE CURB RAMP MAXIMUM RUNNING SLOPE SHALL NOT REQUIRE THE RAMP LENGTH TO EXCEED 15 FEET TO AVOID CHASING THE SLOPE INDEFINITELY WHEN CONNECTING TO STEEP GRADES. WHEN APPLYING THE 15 FOOT MAXIMUM LENGTH THE RUNNING SLOPE OF THE CURB RAMP SHALL BE AS FLAT AS FEASIBLE. CURB RAMP SLOPE INCLUDING TOLERANCE NOT TO EXCEED 8.3%.

LEGEND

SLOPE IN EITHER DIRECTION

APPROVED BY	REVISED DATE	CITY OF OLYMPIA PARALLEL CURB RAMP TYPE A	STD. PLAN NO.
CITY ENGINEER	DATE		4-12D

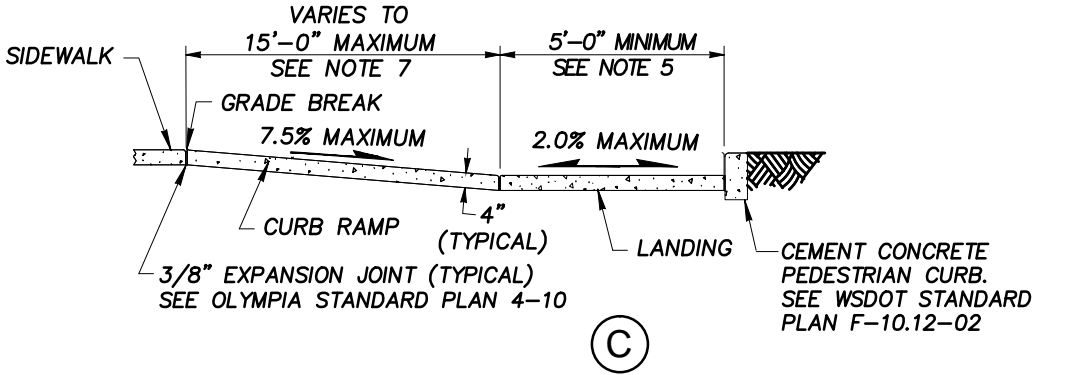
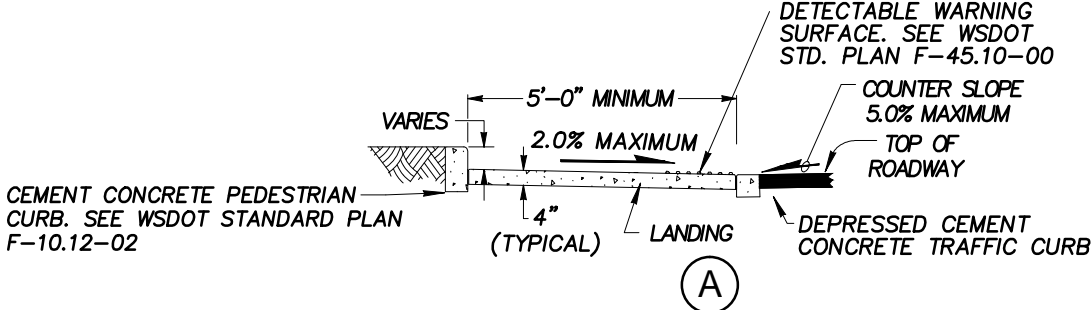
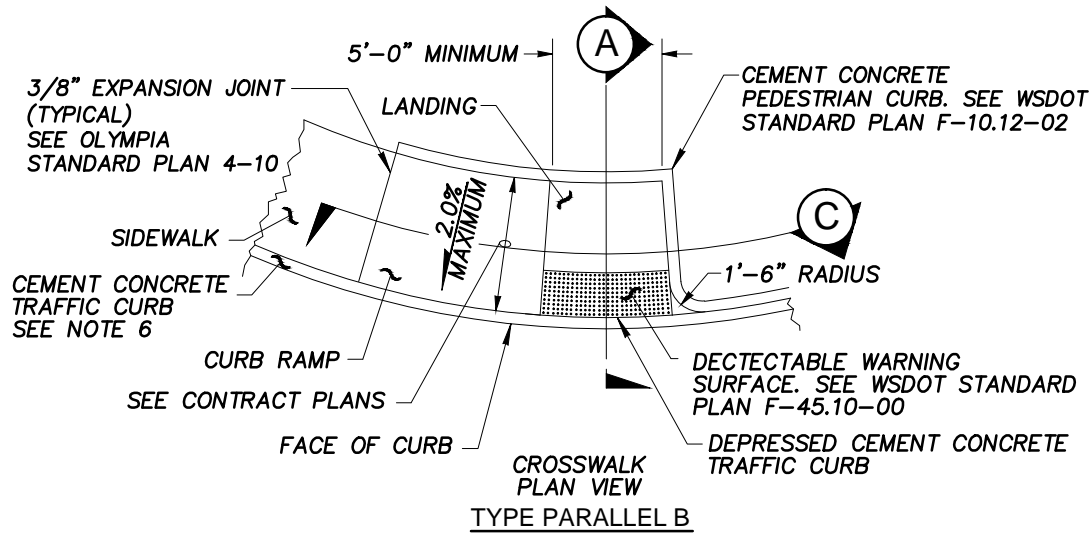

NOTES:

1. IT IS THE INTENT OF THE ENGINEERING DESIGN AND DEVELOPMENT STANDARDS TO HAVE CONSTRUCTED ACCESS RAMPS THAT MINIMIZE PEDESTRIAN CROSSING DISTANCES, AND POSITION PEDESTRIANS WHERE THEY CAN BEST BE SEEN BY ONCOMING TRAFFIC. CURB RAMP ORIENTATION WILL ALIGN PEDESTRIANS PARALLEL WITHIN THE LATERAL EXTENSION LINES OF THE SIDEWALK. INTERSECTION RADIUS LESS THAN 35' WILL USE TWO PERPENDICULAR CURB ACCESS RAMPS PER CORNER. WHERE INTERSECTION CORNERS ARE OFF-SET, CURB ACCESS RAMPS WILL ORIENTATE DIAGONALLY TO THE OPPOSING CURB ACCESS RAMP. LANDING BETWEEN ACCESS RAMPS WILL NOT BE LESS THAN 5' WITH A SLOPE NO GREATER THAN 2.0%. CENTER AND DIRECTION OF RAMP SHALL BE LOCATED WITHIN CROSSWALK LINES AS CLOSE AND PARALLEL TO CROSSWALK CENTERLINE AS POSSIBLE. SEE OLYMPIA STANDARD PLAN 4-32.
2. GRADE BREAKS AT THE TOP AND BOTTOM OF THE CURB RAMP WILL BE PERPENDICULAR TO THE DIRECTION OF THE RAMP. ANY TRIANGLE LANDING BETWEEN THE GRADE BREAK AND THE CURB WILL BE 2.0% MAXIMUM SLOPE. THE ENTIRE LENGTH OF THE GRADE BREAK BETWEEN THE TWO ADJACENT SURFACE PLANES SHALL BE FLUSH.
3. PLACED JUNCTION BOXES, ACCESS COVERS, OR OTHER APPURTENANCES IN CURB RAMP SHALL BE ADA COMPLIANT. DO NOT PLACE GRATING IN FRONT OF OR IN ANY PART OF THE CURB RAMP OR LANDING.
4. CURB RAMP LANDING, AND FLARES SHALL RECEIVE BROOM FINISH. SEE WSDOT STANDARD SPECIFICATIONS 8-14.
5. CURB RAMP WIDTH AND LANDINGS MAY BE REDUCED TO 4'-0" WITH APPROVAL FROM CITY ENGINEER.
6. USE OLYMPIA STANDARD PLAN 4-14 WHEN BICYCLE LANE IS PRESENT OR PLANNED OR OLYMPIA STANDARD PLAN 4-14A WHEN BICYCLE LANE IS NOT PRESENT OR PLANNED.
7. THE CURB RAMP MAXIMUM RUNNING SLOPE SHALL NOT REQUIRE THE RAMP LENGTH TO EXCEED 15 FEET TO AVOID CHASING THE SLOPE INDEFINITELY WHEN CONNECTING TO STEEP GRADES. WHEN APPLYING THE 15 FOOT MAXIMUM LENGTH THE RUNNING SLOPE OF THE CURB RAMP SHALL BE AS FLAT AS FEASIBLE. CURB RAMP SLOPE INCLUDING TOLERANCE NOT TO EXCEED 8.3%.

LEGEND
 SLOPE IN EITHER DIRECTION

APPROVED BY	REVISED DATE	CITY OF OLYMPIA PARALLEL CURB RAMP TYPE B	STD. PLAN NO.
CITY ENGINEER	DATE		4-12E

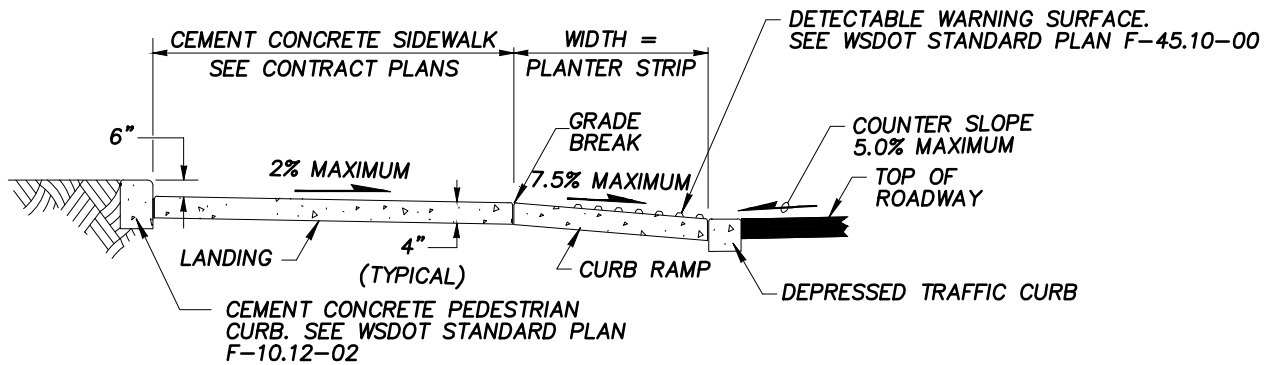
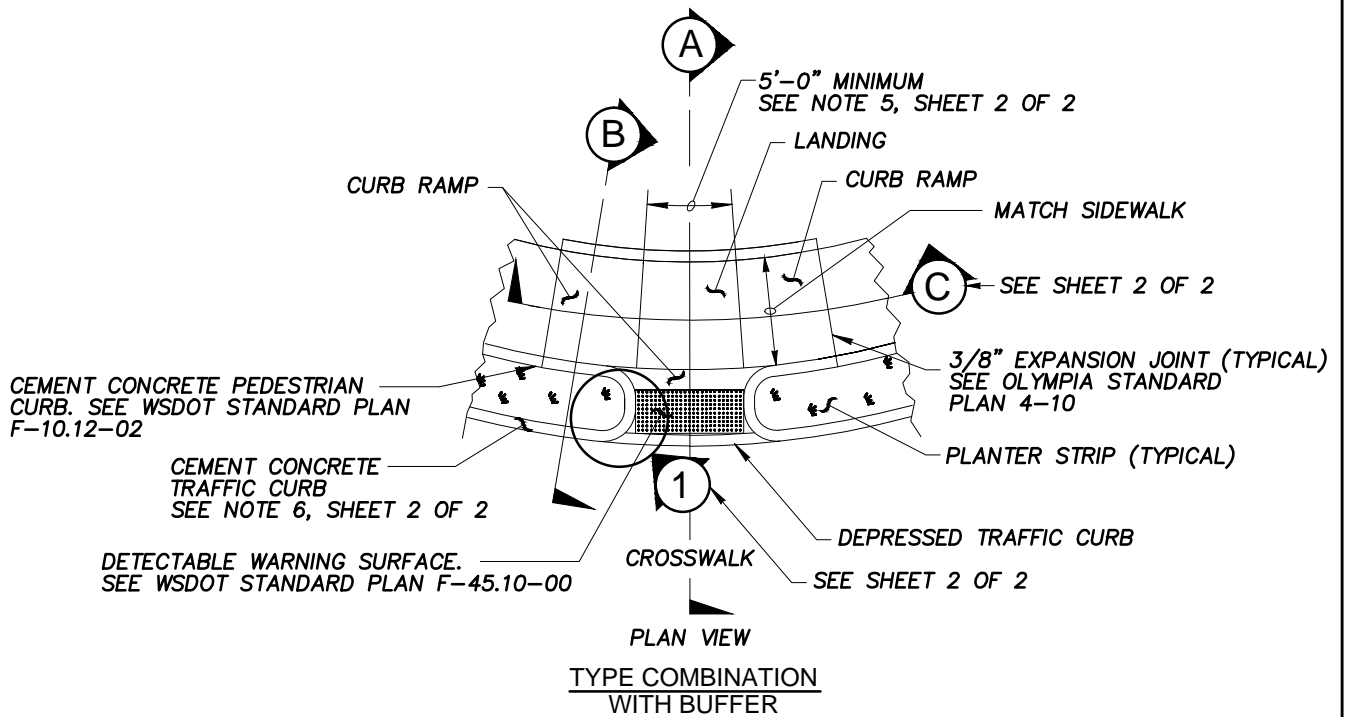

SECTION (A)

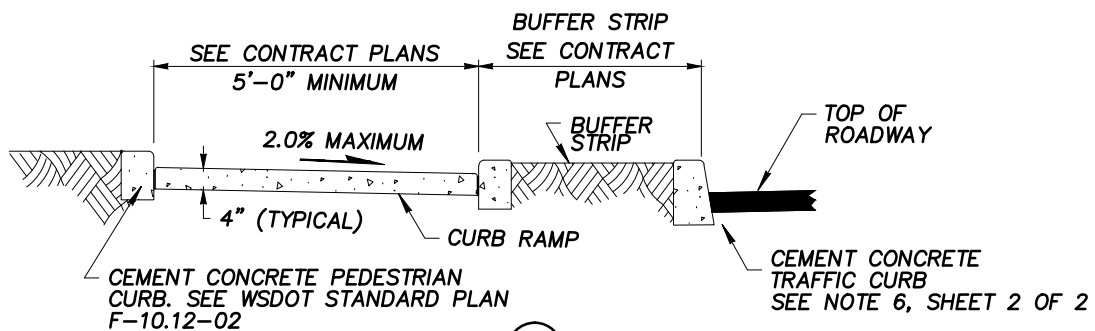

SECTION (B)

NOTE:
SEE SHEET 2 OF 2 FOR NOTES.

LEGEND
SLOPE IN EITHER DIRECTION

APPROVED BY	REVISED DATE	CITY OF OLYMPIA	STD. PLAN NO.
CITY ENGINEER	DATE	COMBINATION CURB RAMP	4-12F SHEET 1 OF 2

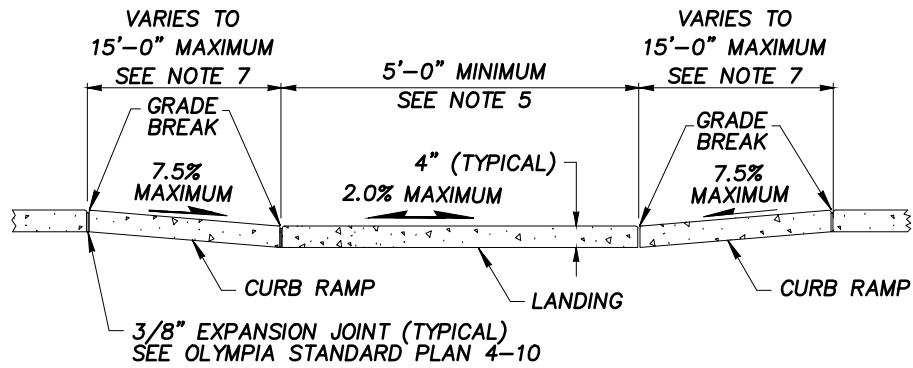

(C)

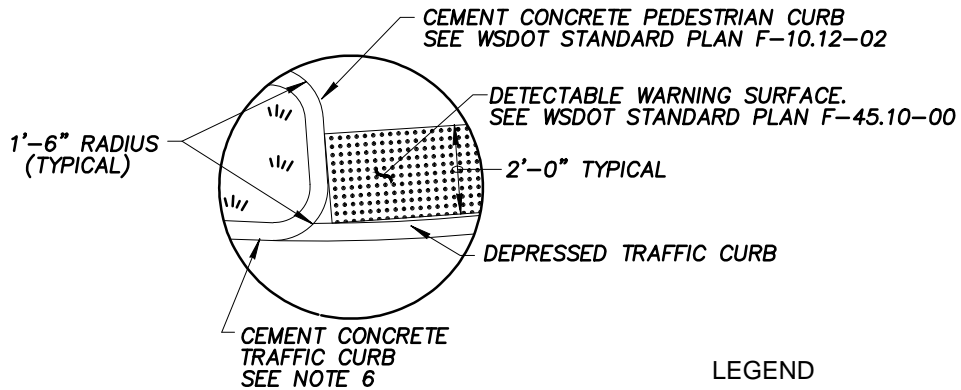

(1)

LEGEND

 SLOPE IN EITHER DIRECTION

NOTES:

1. IT IS THE INTENT OF THE ENGINEERING DESIGN AND DEVELOPMENT STANDARDS TO HAVE CONSTRUCTED ACCESS RAMPS THAT MINIMIZE PEDESTRIAN CROSSING DISTANCES, AND POSITION PEDESTRIANS WHERE THEY CAN BEST BE SEEN BY ONCOMING TRAFFIC. CURB RAMP ORIENTATION WILL ALIGN PEDESTRIANS PARALLEL WITHIN THE LATERAL EXTENSION LINES OF THE SIDEWALK. INTERSECTION RADIUS LESS THAN 35' WILL USE TWO PERPENDICULAR CURB ACCESS RAMPS PER CORNER. WHERE INTERSECTION CORNERS ARE OFF-SET, CURB ACCESS RAMPS WILL ORIENTATE DIAGONALLY TO THE OPPOSING CURB ACCESS RAMP. LANDING BETWEEN ACCESS RAMPS WILL NOT BE LESS THAN 5' WITH A SLOPE NO GREATER THAN 2.0%. CENTER AND DIRECTION OF RAMP SHALL BE LOCATED WITHIN CROSSWALK LINES AS CLOSE AND PARALLEL TO CROSSWALK CENTERLINE AS POSSIBLE. SEE OLYMPIA STANDARD PLAN 4-32.
2. GRADE BREAKS AT THE TOP AND BOTTOM OF THE CURB RAMP WILL BE PERPENDICULAR TO THE DIRECTION OF THE RAMP. ANY TRIANGLE LANDING BETWEEN THE GRADE BREAK AND THE CURB WILL BE 2.0% MAXIMUM SLOPE. THE ENTIRE LENGTH OF THE GRADE BREAK BETWEEN THE TWO ADJACENT SURFACE PLANES SHALL BE FLUSH.
3. PLACED JUNCTION BOXES, ACCESS COVERS, OR OTHER APPURTENANCES IN CURB RAMP SHALL BE ADA COMPLIANT. DO NOT PLACE GRATING IN FRONT OF OR IN ANY PART OF THE CURB RAMP OR LANDING.
4. CURB RAMP LANDING, AND FLARES SHALL RECEIVE BROOM FINISH. SEE WSDOT STANDARD SPECIFICATIONS 8-14.
5. CURB RAMP WIDTH AND LANDINGS MAY BE REDUCED TO 4'-0" WITH APPROVAL FROM CITY ENGINEER.
6. USE OLYMPIA STANDARD PLAN 4-14 WHEN BICYCLE LANE IS PRESENT OR PLANNED OR OLYMPIA STANDARD PLAN 4-14A WHEN BICYCLE LANE IS NOT PRESENT OR PLANNED.
7. THE CURB RAMP MAXIMUM RUNNING SLOPE SHALL NOT REQUIRE THE RAMP LENGTH TO EXCEED 15 FEET TO AVOID CHASING THE SLOPE INDEFINITELY WHEN CONNECTING TO STEEP GRADES. WHEN APPLYING THE 15 FOOT MAXIMUM LENGTH THE RUNNING SLOPE OF THE CURB RAMP SHALL BE AS FLAT AS FEASIBLE. CURB RAMP SLOPE INCLUDING TOLERANCE NOT TO EXCEED 8.3%.

APPROVED BY	REVISED DATE	CITY OF OLYMPIA	STD. PLAN NO.
CITY ENGINEER	DATE		COMBINATION CURB RAMP

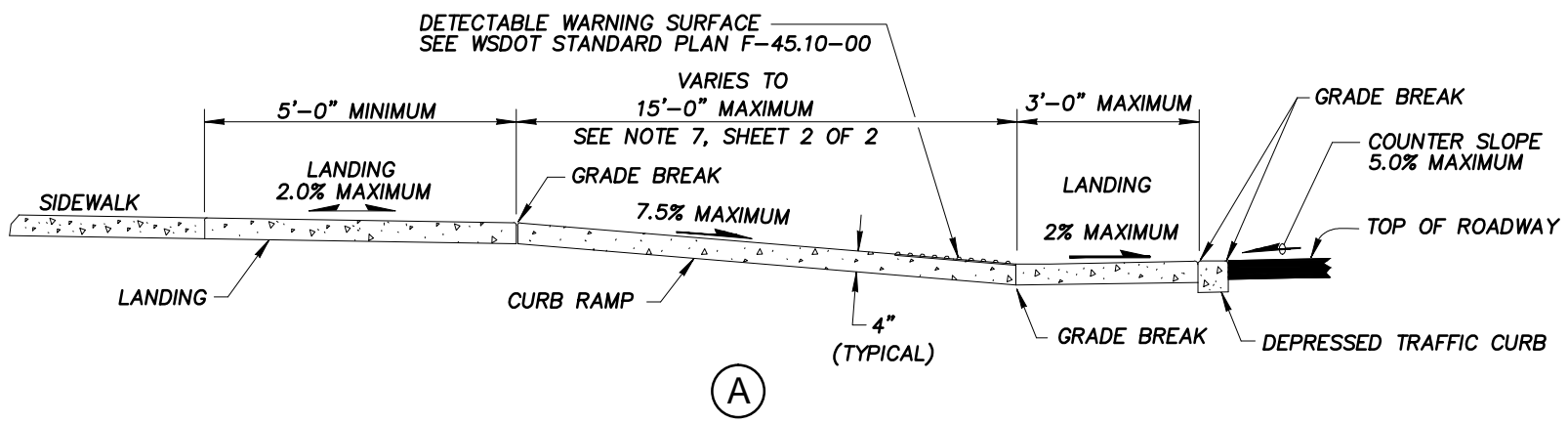
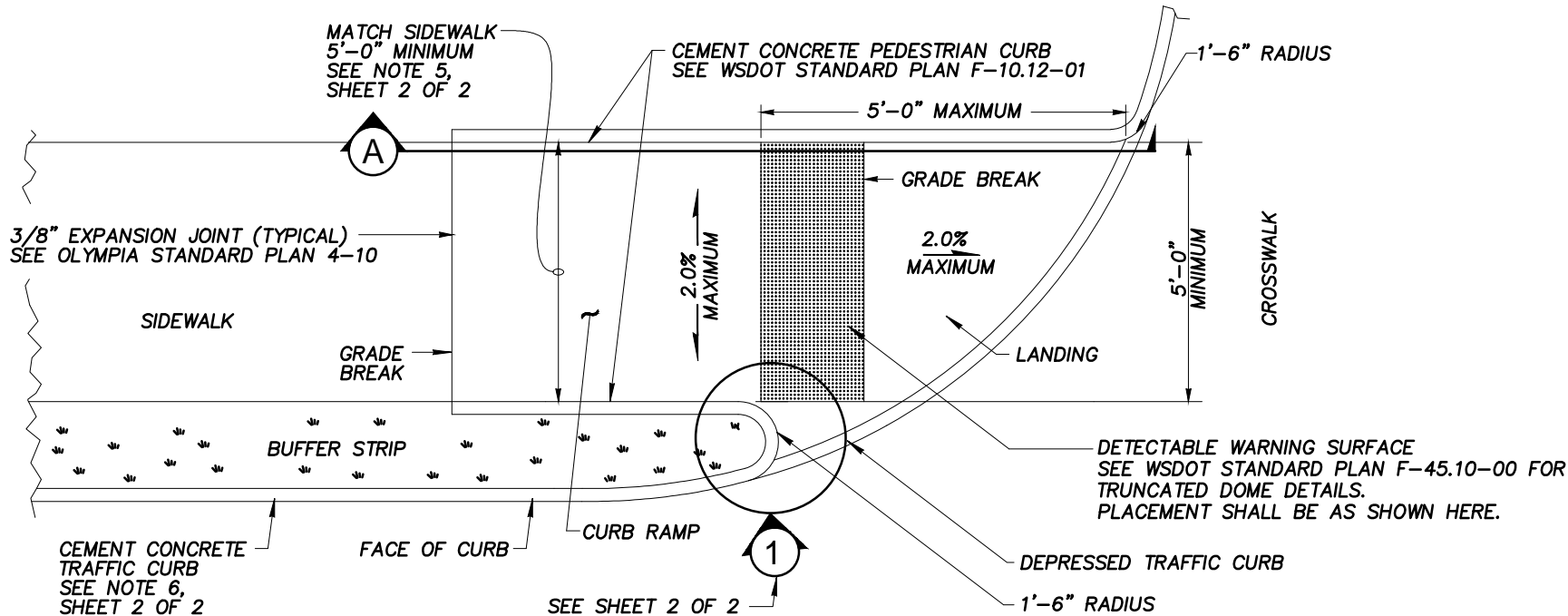

LEGEND

↔
SLOPE IN EITHER DIRECTION

NOTE:
SEE SHEET 2 OF 2 FOR NOTES.

APPROVED BY	REVISED DATE	CITY OF OLYMPIA	STD. PLAN NO.
CITY ENGINEER	DATE		4-12G SHEET 1 OF 2
		SINGLE DIRECTION CURB RAMP	4-12G.Dwg

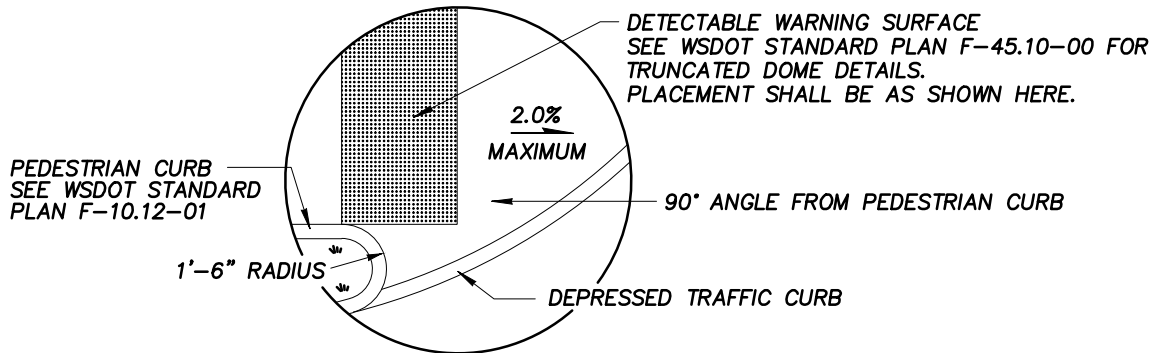

1

LEGEND

↔
SLOPE IN EITHER DIRECTION

NOTES:

1. IT IS THE INTENT OF THE ENGINEERING DESIGN AND DEVELOPMENT STANDARDS TO HAVE CONSTRUCTED ACCESS RAMPS THAT MINIMIZE PEDESTRIAN CROSSING DISTANCES, AND POSITION PEDESTRIANS WHERE THEY CAN BEST BE SEEN BY ONCOMING TRAFFIC. CURB RAMP ORIENTATION WILL ALIGN PEDESTRIANS PARALLEL WITHIN THE LATERAL EXTENSION LINES OF THE SIDEWALK. INTERSECTION RADIUS LESS THAN 35' WILL USE TWO PERPENDICULAR CURB ACCESS RAMPS PER CORNER. WHERE INTERSECTION CORNERS ARE OFF-SET, CURB ACCESS RAMPS WILL ORIENTATE DIAGONALLY TO THE OPPOSING CURB ACCESS RAMP. LANDING BETWEEN ACCESS RAMPS WILL NOT BE LESS THAN 5' WITH A SLOPE NO GREATER THAN 2.0%. CENTER AND DIRECTION OF RAMP SHALL BE LOCATED WITHIN CROSSWALK LINES AS CLOSE AND PARALLEL TO CROSSWALK CENTERLINE AS POSSIBLE. SEE OLYMPIA STANDARD PLAN 4-32.
2. GRADE BREAKS AT THE TOP AND BOTTOM OF THE CURB RAMP WILL BE PERPENDICULAR TO THE DIRECTION OF THE RAMP. ANY TRIANGLE LANDING BETWEEN THE GRADE BREAK AND THE CURB WILL BE 2.0% MAXIMUM SLOPE. THE ENTIRE LENGTH OF THE GRADE BREAK BETWEEN THE TWO ADJACENT SURFACE PLANES SHALL BE FLUSH.
3. PLACED JUNCTION BOXES, ACCESS COVERS, OR OTHER APPURTENANCES IN CURB RAMP SHALL BE ADA COMPLIANT. DO NOT PLACE GRATING IN FRONT OF OR IN ANY PART OF THE CURB RAMP OR LANDING.
4. CURB RAMP LANDING, AND FLARES SHALL RECEIVE BROOM FINISH. SEE WSDOT STANDARD SPECIFICATIONS 8-14.
5. CURB RAMP WIDTH AND LANDINGS MAY BE REDUCED TO 4'-0" WITH APPROVAL FROM CITY ENGINEER.
6. USE OLYMPIA STANDARD PLAN 4-14 WHEN BICYCLE LANE IS PRESENT OR PLANNED OR OLYMPIA STANDARD PLAN 4-14A WHEN BICYCLE LANE IS NOT PRESENT OR PLANNED.
7. THE CURB RAMP MAXIMUM RUNNING SLOPE SHALL NOT REQUIRE THE RAMP LENGTH TO EXCEED 15 FEET TO AVOID CHASING THE SLOPE INDEFINITELY WHEN CONNECTING TO STEEP GRADES. WHEN APPLYING THE 15 FOOT MAXIMUM LENGTH THE RUNNING SLOPE OF THE CURB RAMP SHALL BE AS FLAT AS FEASIBLE. CURB RAMP SLOPE INCLUDING TOLERANCE NOT TO EXCEED 8.3%.

APPROVED BY	REVISED DATE	CITY OF OLYMPIA	STD. PLAN NO.
CITY ENGINEER	DATE		4-12G1 SHEET 2 OF 2

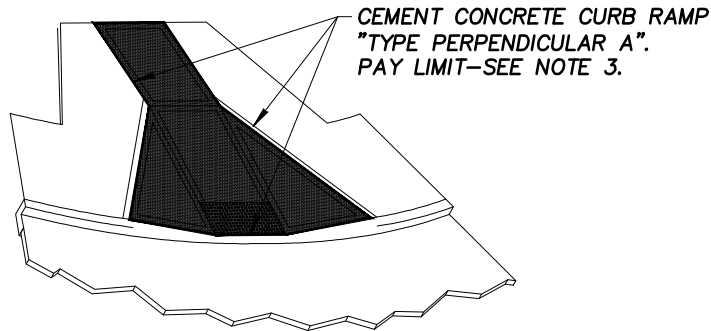

CEMENT CONCRETE CURB RAMP
"TYPE PERPENDICULAR A".
PAY LIMIT—SEE NOTE 3.

ISOMETRIC VIEW—TYPE PERPENDICULAR A

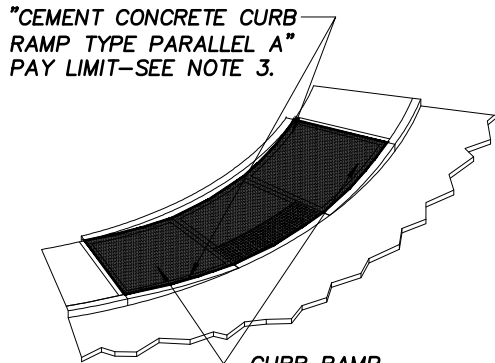

"CEMENT CONCRETE CURB
RAMP TYPE PARALLEL A"
PAY LIMIT—SEE NOTE 3.

— CURB RAMP
TRANSITION SLOPE

ISOMETRIC VIEW—TYPE PARALLEL A

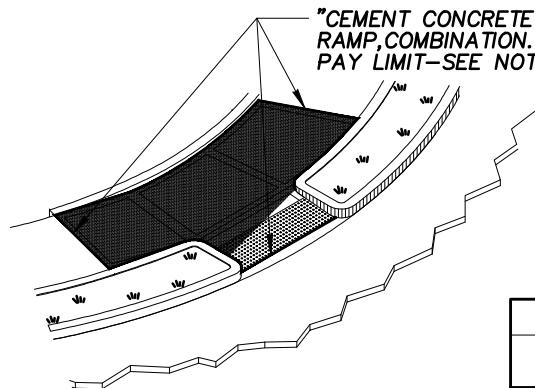

"CEMENT CONCRETE CURB
RAMP, COMBINATION."
PAY LIMIT—SEE NOTE 3.

ISOMETRIC VIEW —TYPE COMBINATION

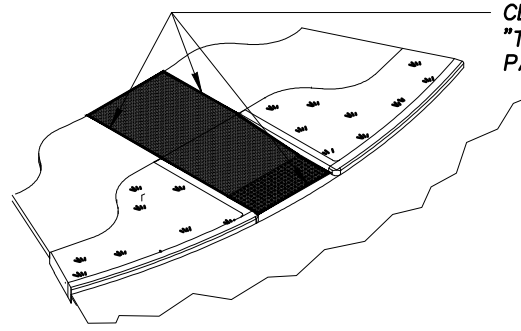

CEMENT CONCRETE CURB RAMP
"TYPE PERPENDICULAR B".
PAY LIMIT—SEE NOTE 3.

ISOMETRIC VIEW—TYPE PERPENDICULAR B

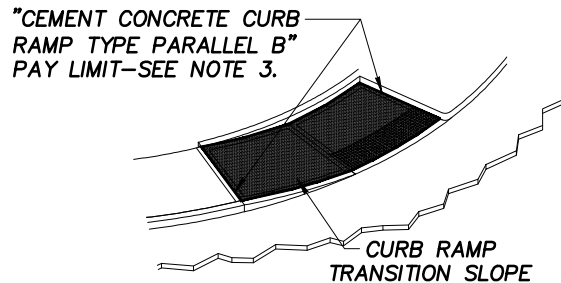

"CEMENT CONCRETE CURB
RAMP TYPE PARALLEL B"
PAY LIMIT—SEE NOTE 3.

— CURB RAMP
TRANSITION SLOPE

ISOMETRIC VIEW—TYPE PARALLEL B

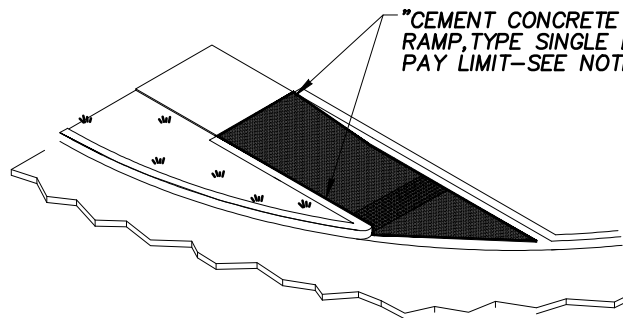

"CEMENT CONCRETE CURB
RAMP, TYPE SINGLE DIRECTION A".
PAY LIMIT—SEE NOTE 3.

ISOMETRIC VIEW—TYPE SINGLE DIRECTION A

NOTES:

1. SEE CONTRACT PLANS FOR THE CURB DESIGN SPECIFIED. SEE OLYMPIA STANDARD PLANS 4-14 (SERIES) FOR TRAFFIC CURB, CURB AND GUTTER, AND PEDESTRIAN CURB DETAILS.

2. SEE OLYMPIA STANDARD PLANS 4-9 (SERIES), 4-10 FOR CEMENT CONCRETE SIDEWALK DETAILS. SEE CONTRACT PLANS FOR WIDTH AND PLACEMENT OF SIDEWALK.

3. THE BID ITEM "CEMENT CONCRETE RAMP TYPE ____" DOES NOT INCLUDE THE ADJACENT CURB, CURB AND GUTTER, PEDESTRIAN CURB OR SIDEWALKS.

4. WHEN APPLYING THE 15' MAXIMUM LENGTH, THE RUNNING SLOPE OF THE CURB RAMP SHALL BE AS FLAT AS FEASIBLE.

5. THIS STANDARD PLAN IS APPLICABLE ONLY FOR PUBLIC WORKS PROJECTS.

APPROVED BY	REVISED DATE	CITY OF OLYMPIA	STD. PLAN NO.
CITY ENGINEER	DATE		CURB RAMP PAY LIMITS

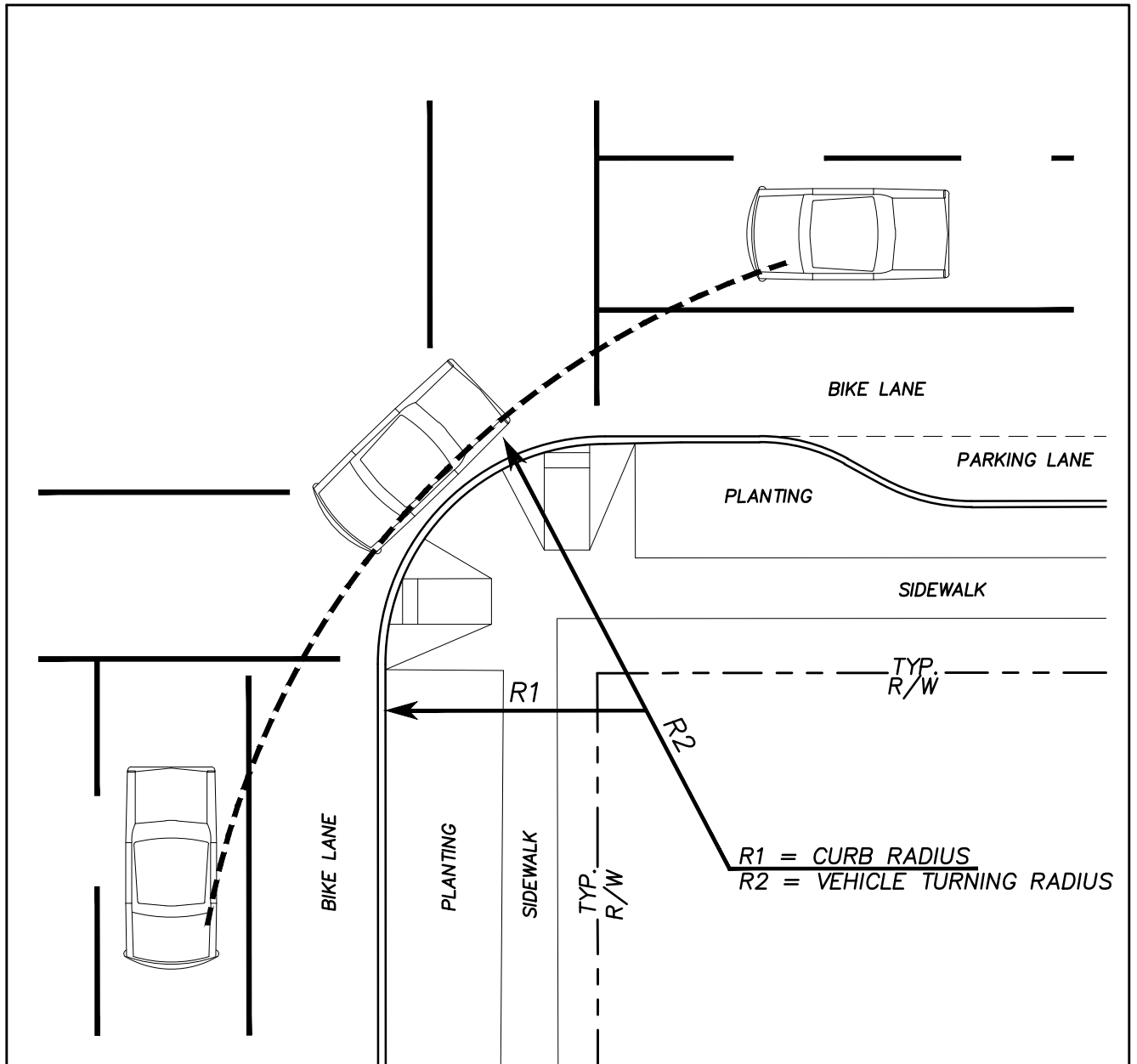

NOTES:

1. SEE MINIMUM STREET DESIGN STANDARDS TABLE 1 FOR VEHICLE TURNING RADIUS DIMENSION PER FUNCTIONAL STREET CLASSIFICATION.
2. REFER TO ENGINEERING DEVELOPMENT DESIGN STANDARDS CHAPTER 4 TABLE 2, MINIMUM STREET DESIGN STANDARDS FOOTNOTE 7 FOR ADDITIONAL GUIDANCE ON TURNING RADIUS DESIGN.

APPROVED BY	REVISED DATE	CITY OF OLYMPIA	STD. PLAN NO.
	6/11/2012	INTERSECTION RADII	4-13
CITY ENGINEER			

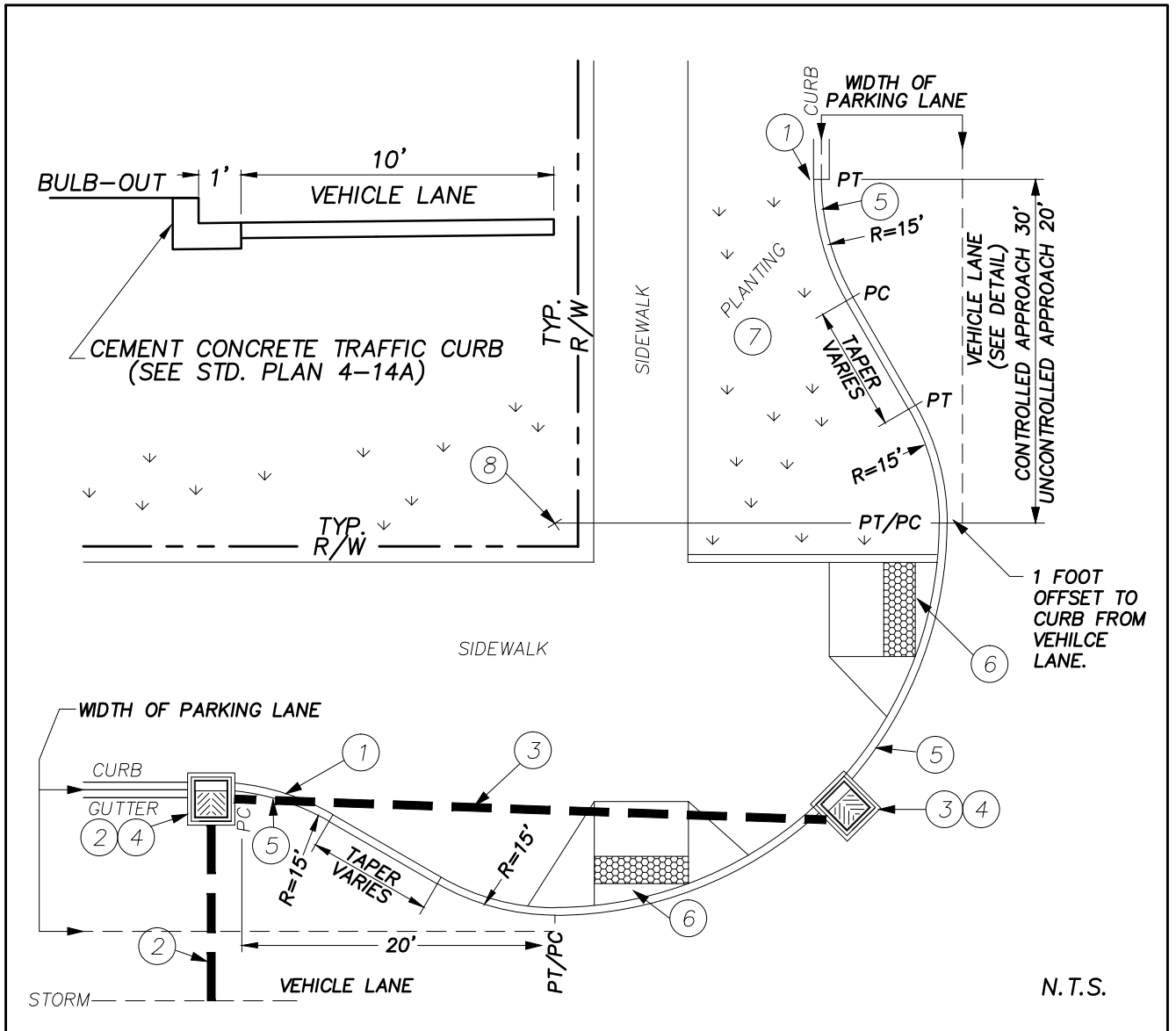

N. T. S.

NOTES:

1. SAW CUT AND REMOVE EXISTING CONCRETE CURB OR SURFACE.
2. IF EXISTING STORM DRAINAGE LINE EXISTS INSTALL 12" STORM SEWER ON THE UPHILL SIDE OF ROUNDED CORNER AS NEEDED FOR DRAINAGE. MAINTAIN 2' MINIMUM COVER OVER PIPE. GRADE TO DRAIN.
3. IF NO STORM DRAINAGE LINE EXISTS INSTALL 12" STORM SEWER MAINTAIN 2' OF MINIMUM COVER OVER STORM SEWER PIPE. STORM PIPE SLOPE TO MATCH GUTTER GRADE.
4. CATCH BASIN TYPE 1L TYP. (SEE W.S.D.O.T. STANDARD PLAN B-5.40-00) HOODED CATCH BASIN FRAME & GRATE (SEE CITY OF OLYMPIA STANDARD PLANS 5-9 AND 5-9A)
5. CEMENT CONCRETE TRAFFIC CURB (SEE CITY OF OLYMPIA STANDARD PLAN 4-14)
6. PERPEDICULAR CURB OR COMBINATION RAMP. (SEE CITY OF OLYMPIA STANDARD PLAN 4-12A OR 4-12B)
7. 1' DEEP TYPE C TOP SOIL FOR LANDSCAPING.
8. RADIUS VARIES - SEE E.D.D.S. CHAPTER 4, TABLE 2 - INTERSECTION RADII.

APPROVED BY	REVISED DATE	CITY OF OLYMPIA CURB BULB-OUT ADJACENT TO VEHICLE LANE	STD. PLAN NO.
CITY ENGINEER	5/09/2011		4-13A

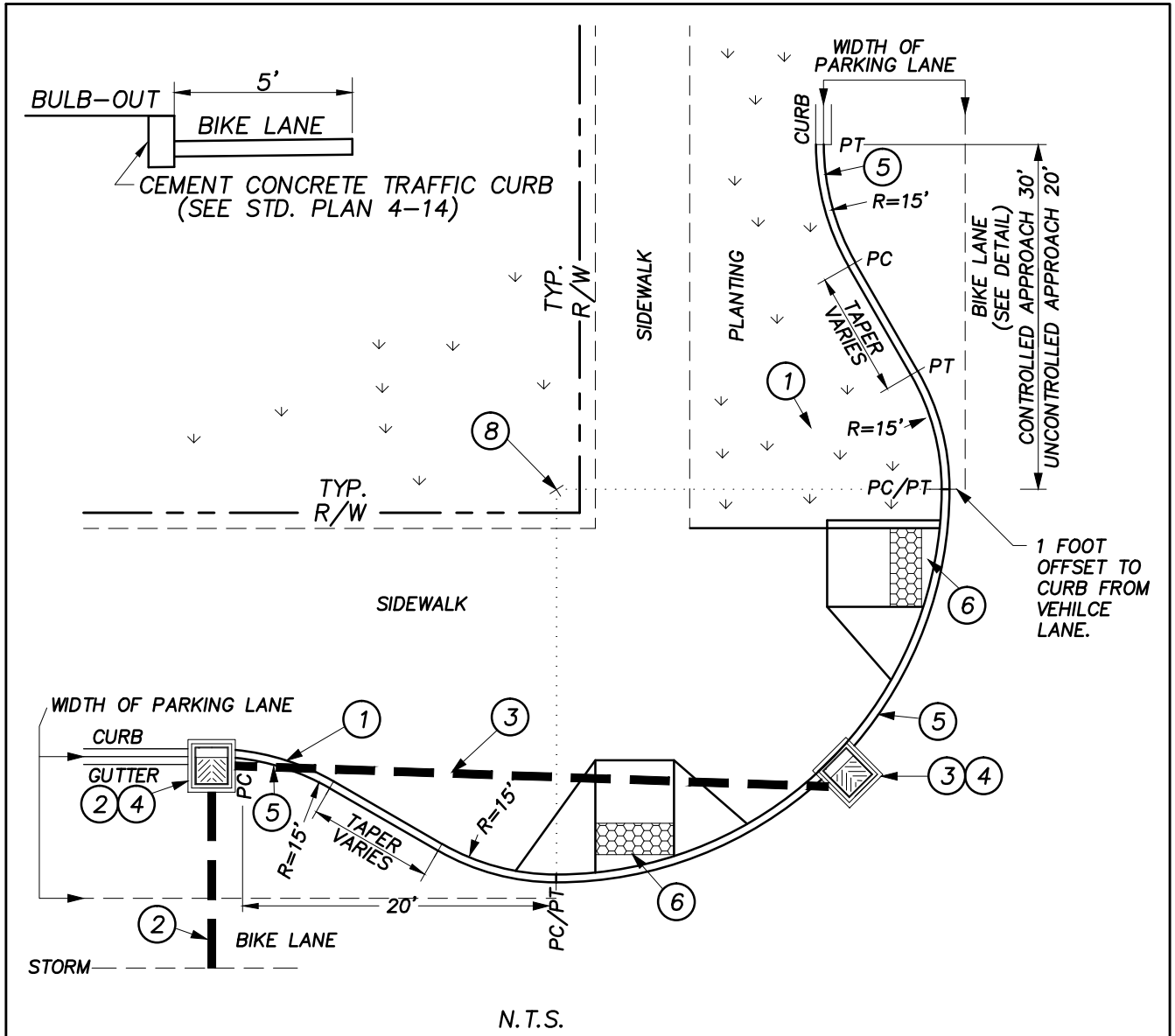

N.T.S.

NOTES:

1. SAW CUT AND REMOVE EXISTING CONCRETE CURB OR SURFACE.
2. IF EXISTING STORM DRAINAGE LINE EXISTS INSTALL 12" STORM SEWER ON THE UPHILL SIDE OF ROUNDED CORNER AS NEEDED FOR DRAINAGE. MAINTAIN 2' MINIMUM COVER OVER PIPE. GRADE TO DRAIN.
3. IF NO STORM DRAINAGE LINE EXISTS INSTALL 12" STORM SEWER MAINTAIN 2' OF MINIMUM COVER OVER STORM SEWER PIPE. STORM PIPE SLOPE TO MATCH GUTTER GRADE.
4. CATCH BASIN TYPE 1L TYP. (SEE W.S.D.O.T. STANDARD PLAN B-5.40-00) HOODED CATCH BASIN FRAME & GRATE (SEE CITY OF OLYMPIA STANDARD PLANS 5-9 AND 5-9A)
5. CEMENT CONCRETE TRAFFIC CURB (SEE CITY OF OLYMPIA STANDARD PLAN 4-14)
6. PERPEDICULAR CURB OR COMBINATION RAMP. (SEE CITY OF OLYMPIA STANDARD PLAN 4-12A OR 4-12B)
7. 1' DEEP TYPE C TOP SOIL FOR LANDSCAPING.
8. RADIUS VARIES - SEE E.D.D.S. CHAPTER 4, TABLE 2 - INTERSECTION RADII.

APPROVED BY	REVISED DATE	CITY OF OLYMPIA CURB BULB-OUT ADJACENT TO BIKE LANE	STD. PLAN NO.
CITY ENGINEER	5/09/2011		4-13A1

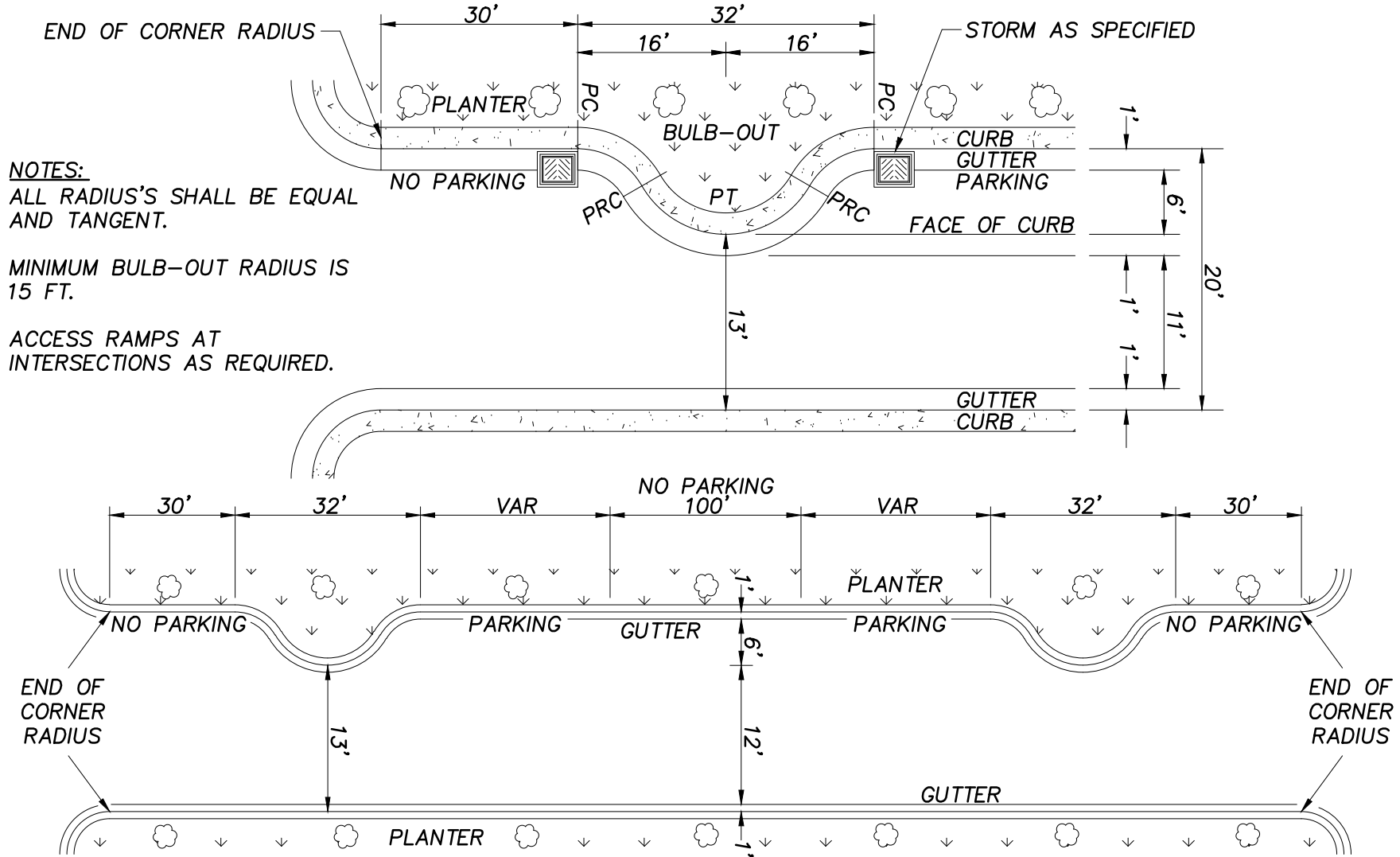

NOTES:
 ALL RADIUS'S SHALL BE EQUAL AND TANGENT.
 MINIMUM BULB-OUT RADIUS IS 15 FT.
 ACCESS RAMPS AT INTERSECTIONS AS REQUIRED.

N.T.S.

APPROVED BY	REVISED DATE	CITY OF OLYMPIA LOCAL ACCESS STREET PARKING BULB-OUT	STD. PLAN NO.
CITY ENGINEER	12/12/06		4-13B

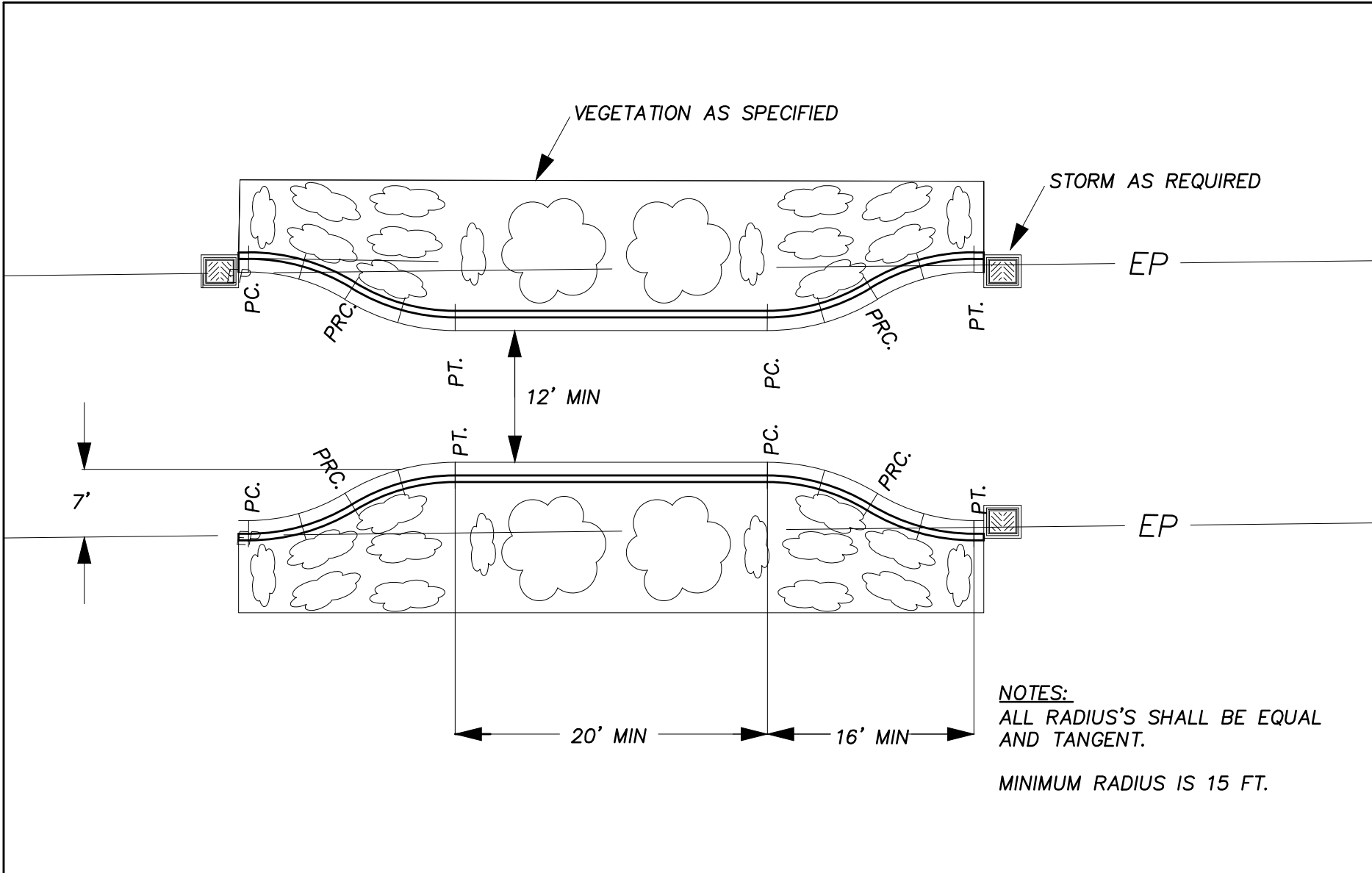

NOTES:
 ALL RADIUS'S SHALL BE EQUAL
 AND TANGENT.

MINIMUM RADIUS IS 15 FT.

APPROVED BY	REVISED DATE	CITY OF OLYMPIA	STD. PLAN NO.
	7/5/06	ONE-LANE NARROW POINT	4-13C
CITY ENGINEER			

ANGLE POINT NOTES:

- ③ IF NO STORM DRAINAGE LINE EXISTS, INSTALL 12" STORM SEWER PIPE AND CATCHBASINS PER DETAIL. MAINTAIN 2' MINIMUM COVER OVER PIPE. SLOPE TO MATCH GUTTER GRADE.
- ③A IF AN STORM DRAINAGE LINE EXISTS, INSTALL CATCHBASINS ON THE UPHILL SIDE OF THE ANGLE POINTS. CONNECT TO EXISTING STORM LINE WITH 12" STORM SEWER PIPE. MAINTAIN 2' MINIMUM COVER OVER PIPE, GRADE TO DRAIN.
- ⑤ CEMENT CONCRETE TRAFFIC CURB (SEE CITY OF OLYMPIA STANDARD PLAN 4-14) INSTALL EXPANSION JOINTS AT EACH END & 10'± ON CENTER
- ⑥ 1' TOP SOIL, TYPE C OR AS DIRECTED BY ENGINEER.
- ⑦ LANDSCAPING
- ⑧ DOUBLE YELLOW CENTER STRIPE WITH RPM'S AS LOCATED IN THE FIELD BY THE ENGINEER SEE CITY OF OLYMPIA STANDARD PLAN 4-27B.

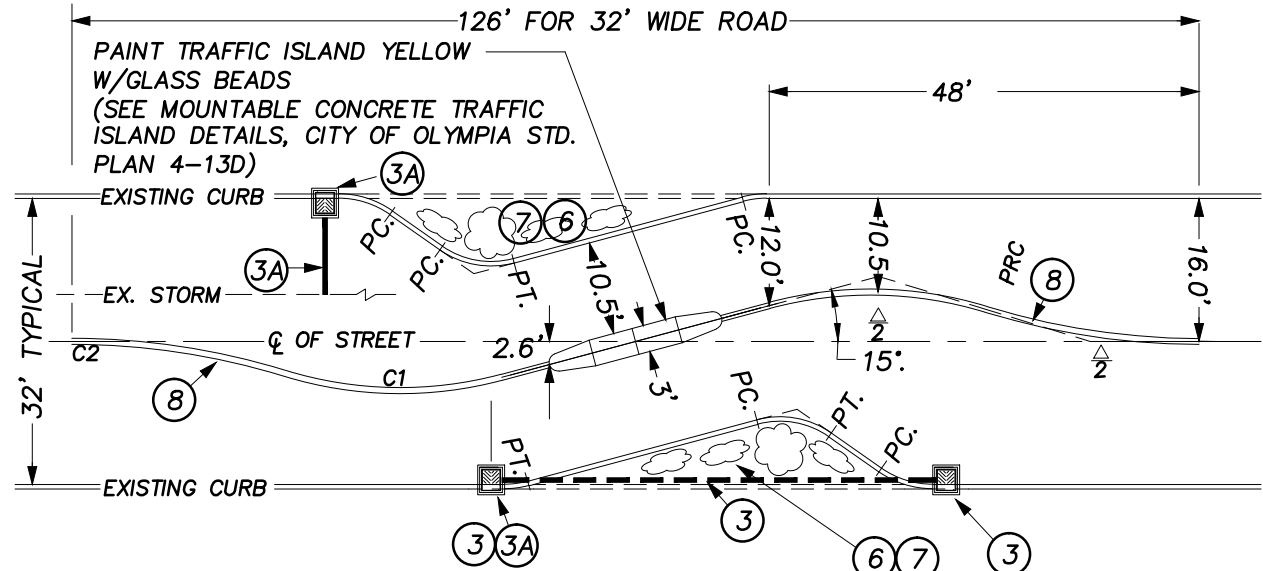

**ANGLE POINT W/ISLAND
N.T.S.**

**ANGLE POINT BULBOUTS
(SEE CITY OF OLYMPIA
STD. PLAN 4-13C1)**

CURVE TABLE

NO.	RADIUS	LENGTH
C1	44	24.6
C2	81	24.2

APPROVED BY	REVISED DATE	CITY OF OLYMPIA	STD. PLAN NO.
	4/12/2011	TWO-WAY ANGLE SLOW POINT	4-13C1 1 OF 2
CITY ENGINEER			

ANGLE POINT NOTES:

③ IF NO STORM DRAINAGE LINE EXISTS, INSTALL 12" STORM SEWER PIPE AND CATCHBASINS PER DETAIL. MAINTAIN 2' MINIMUM COVER OVER PIPE. SLOPE TO MATCH GUTTER GRADE.

③A IF AN STORM DRAINAGE LINE EXISTS, INSTALL CATCHBASINS ON THE UPHILL SIDE OF THE ANGLE POINTS. CONNECT TO EXISTING STORM LINE WITH 12" STORM SEWER PIPE. MAINTAIN 2' MINIMUM COVER OVER PIPE, GRADE TO DRAIN.

⑤ CEMENT CONCRETE TRAFFIC CURB (SEE CITY OF OLYMPIA STANDARD PLAN 4-14) INSTALL EXPANSION JOINTS AT EACH END & 10'± ON CENTER

⑥ 1' TOP SOIL, TYPE C OR AS DIRECTED BY ENGINEER.

⑦ LANDSCAPING

⑧ DOUBLE YELLOW CENTER STRIPE WITH RPM'S AS LOCATED IN THE FIELD BY THE ENGINEER SEE CITY OF OLYMPIA STANDARD PLAN 4-27B.

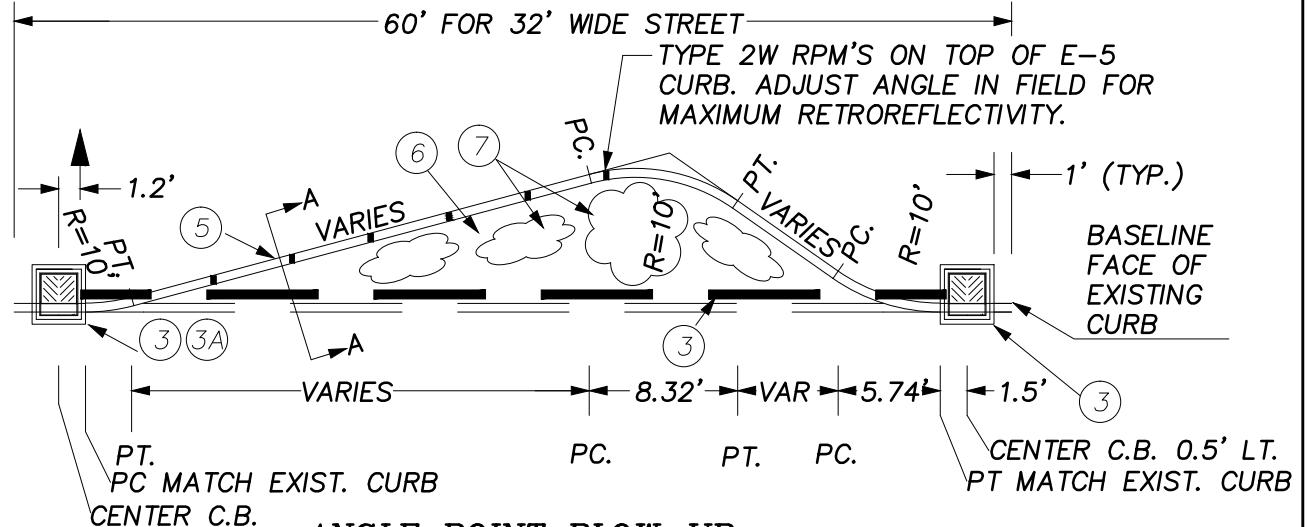

ANGLE POINT BLOW-UP
N.T.S.

NOTE: DIMENSIONS MAY VARY TO MEET FIELD CONDITION

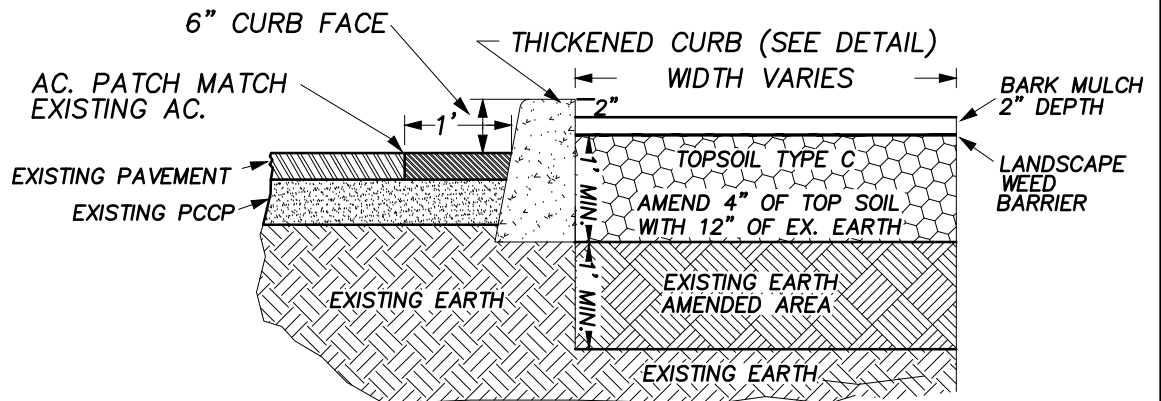

ANGLE POINT, SECTION A-A
N.T.S.

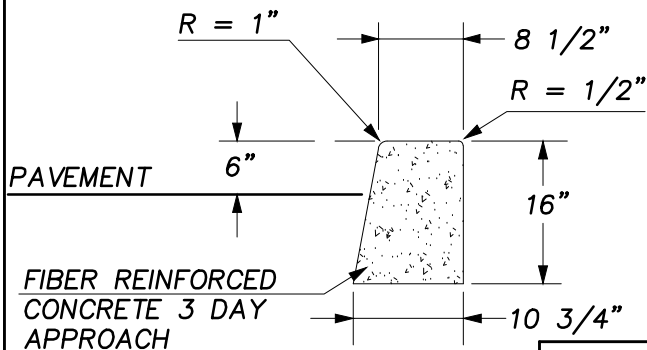

THICKENED CURB

APPROVED BY	REVISED DATE	CITY OF OLYMPIA	STD. PLAN NO.
CITY ENGINEER	2/25/08	TWO-WAY ANGLE SLOW POINT	4-13C2 SHEET 2/2

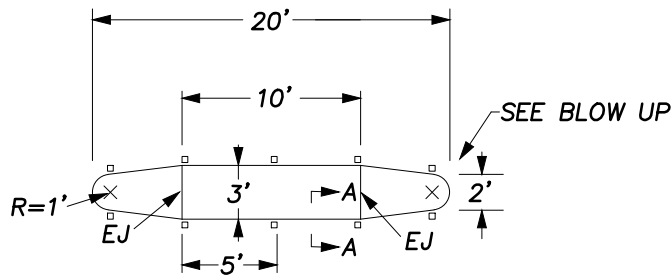

EJ=EXPANSION JOINTS (3/8" WITH 1/2" RADIUS TYPICAL)

MOUNTABLE CONCRETE ISLAND DETAIL
N.T.S.

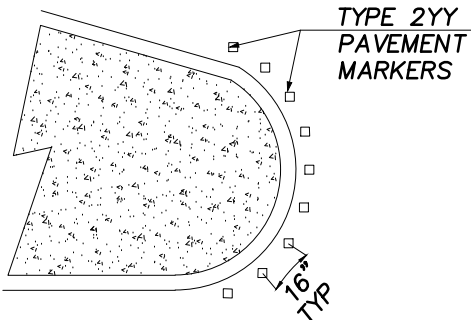

MEDIAN CHANNELIZATION END DETAIL
(NTS)

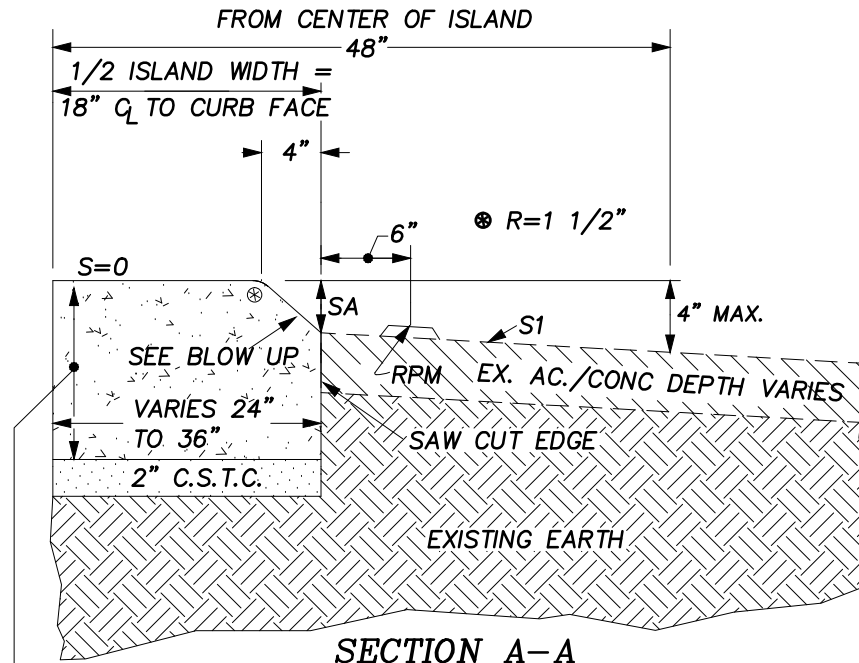

SECTION A-A
N.T.S.

12" MINIMUM OF 3 DAY APPROACH CONCRETE OR MATCH EX. DEPTH OF AC./ CONCRETE ROADWAY WHICH EVER IS GREATER. (BROOM FINISH)

SA=CURB HEIGHT 3 1/2" MINIMUM TO 4" MAXIMUM
S1= EX. AC. SLOPE VARIES

NOTES

1. MAINTAIN 10.5' MIN. LANE WIDTH AT ALL TIMES. FROM CURB FACE TO CURB FACE.
2. CENTER NEW ISLAND BETWEEN EXISTING CURBS AND EXISTING MOUNTABLE CURB ISLAND
3. CONCRETE TO BE POURED TO AC. SAW CUT EDGE. AC. PATCHING SHALL NOT BE ALLOWED.
4. RPMS TYPE 2 YY

APPROVED BY	REVISED DATE	CITY OF OLYMPIA	STD. PLAN NO.
	3/22/2011	MOUNTABLE CONCRETE TRAFFIC ISLAND FOR TWO-WAY ANGLE SLOW POINT	4-13D
CITY ENGINEER			

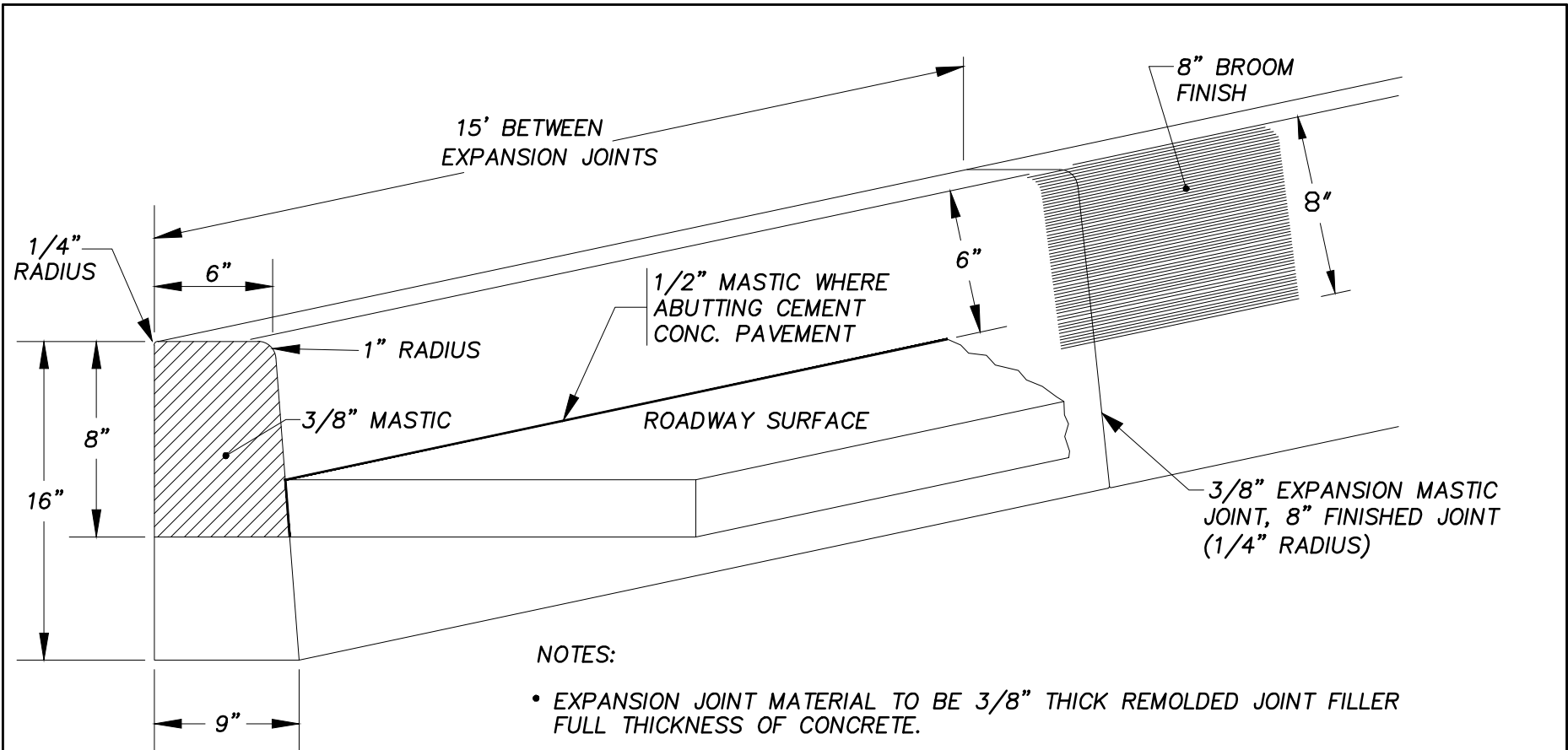

NOTES:

- EXPANSION JOINT MATERIAL TO BE 3/8" THICK REMOLDED JOINT FILLER FULL THICKNESS OF CONCRETE.
- FORM AND SUBGRADE INSPECTION REQUIRED BEFORE POURING CONCRETE.
- JOINTS SHALL BE TROWELED AND FINISHED FORMED, PERPENDICULAR TO STREET AND EXPOSED
- CONCRETE SHALL BE CLASS 3000
- BROOM FINISH TO BE PARALLEL TO STREET
- USE ON STREET CLASIFICATIONS WHERE BIKE LANE IS REQUIRED OR PLANNED.

APPROVED BY	REVISED DATE	CITY OF OLYMPIA CEMENT CONCRETE TRAFFIC CURB	STD. PLAN NO.
CITY ENGINEER	10/27/2008		4-14

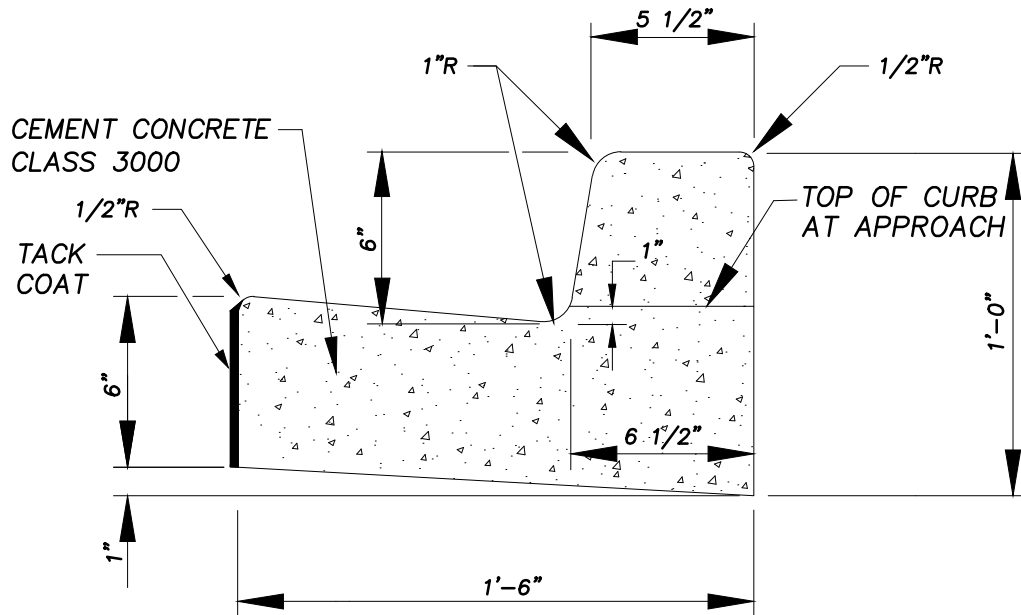

NOTES:

- CANNOT BE INSTALLED ADJACENT TO BIKE LANE.
 - USE CEMENT CONCRETE TRAFFIC CURB (4-14) INSTEAD.
- REFER TO EDDS CHAPTER 4, STREET CLASSIFICATIONS FOR CURB AND GUTTER PLACEMENT.
- SEE ALSO CITY COMPREHENSIVE PLAN – BIKE PLAN – 6-2.
- EXPANSION JOINT MATERIAL TO BE 3/8" THICK PREMOLDED JOINT FILLER FULL THICKNESS OF CONCRETE SPACING.
- FORM AND SUBGRADE INSPECTION REQUIRED BEFORE POURING CONCRETE.

APPROVAL OF
CITY ENGINEER REQUIRED

APPROVED BY	REVISED DATE	CITY OF OLYMPIA	STD. PLAN NO.
	10/28/08	CEMENT CONCRETE CURB & GUTTER	4-14A
CITY ENGINEER			

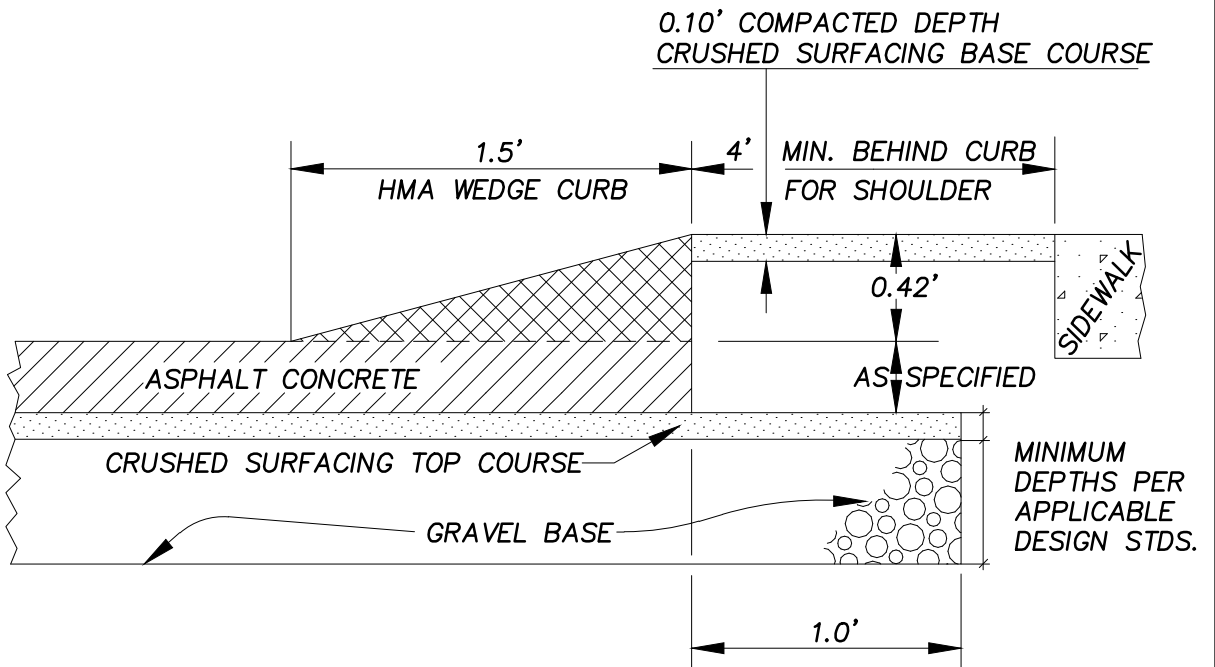

NOTES:

- ASPHALT CONCRETE WEDGE CURB HAS LIMITED APPLICATION. APPROVAL FROM THE PUBLIC WORKS DEPARTMENT IS REQUIRED PRIOR TO DESIGN AND CONSTRUCTION.

APPROVED BY	REVISED DATE	CITY OF OLYMPIA	STD. PLAN NO.
	2/26/08	TYPE "W" HMA WEDGE CURB	4-14B
CITY ENGINEER			

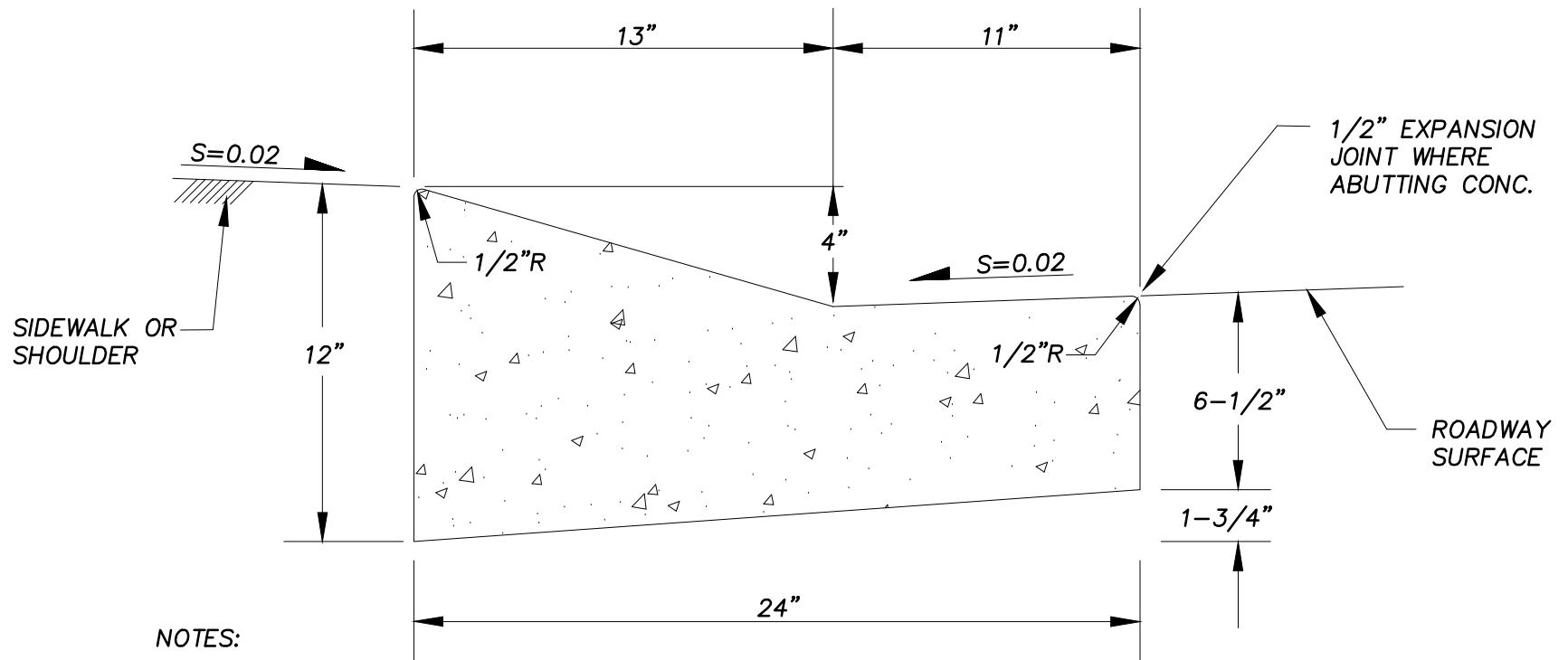

NOTES:

- CEMENT CONCRETE WEDGE CURB & GUTTER HAS LIMITED APPLICATION. APPROVAL FROM PUBLIC WORKS DEPARTMENT IS REQUIRED PRIOR TO DESIGN AND CONSTRUCTION.
- FORM AND SUBGRADE INSPECTION REQUIRED BEFORE POURING CONCRETE.
- CONCRETE SHALL BE CLASS 3000 PORTLAND CEMENT CONCRETE
- DUMMY JOINTS SHALL BE PLACED ON 15 FT. CENTERS UNLESS ABUTTING SIDEWALKS, WHERE JOINTS SHALL BE ALIGNED WITH EXISTING SIDEWALK DUMMY JOINTS, THROUGH JOINTS, ETC.
- EXPANSION JOINT MATERIAL TO BE 3/8" THICK PREMOLDED JOINT FILLER FULL THICKNESS OF CONCRETE SPACING.

APPROVED BY	REVISED DATE	CITY OF OLYMPIA	STD. PLAN NO.
	7/7/06	CEMENT CONCRETE WEDGE CURB & GUTTER	4-14C
CITY ENGINEER			

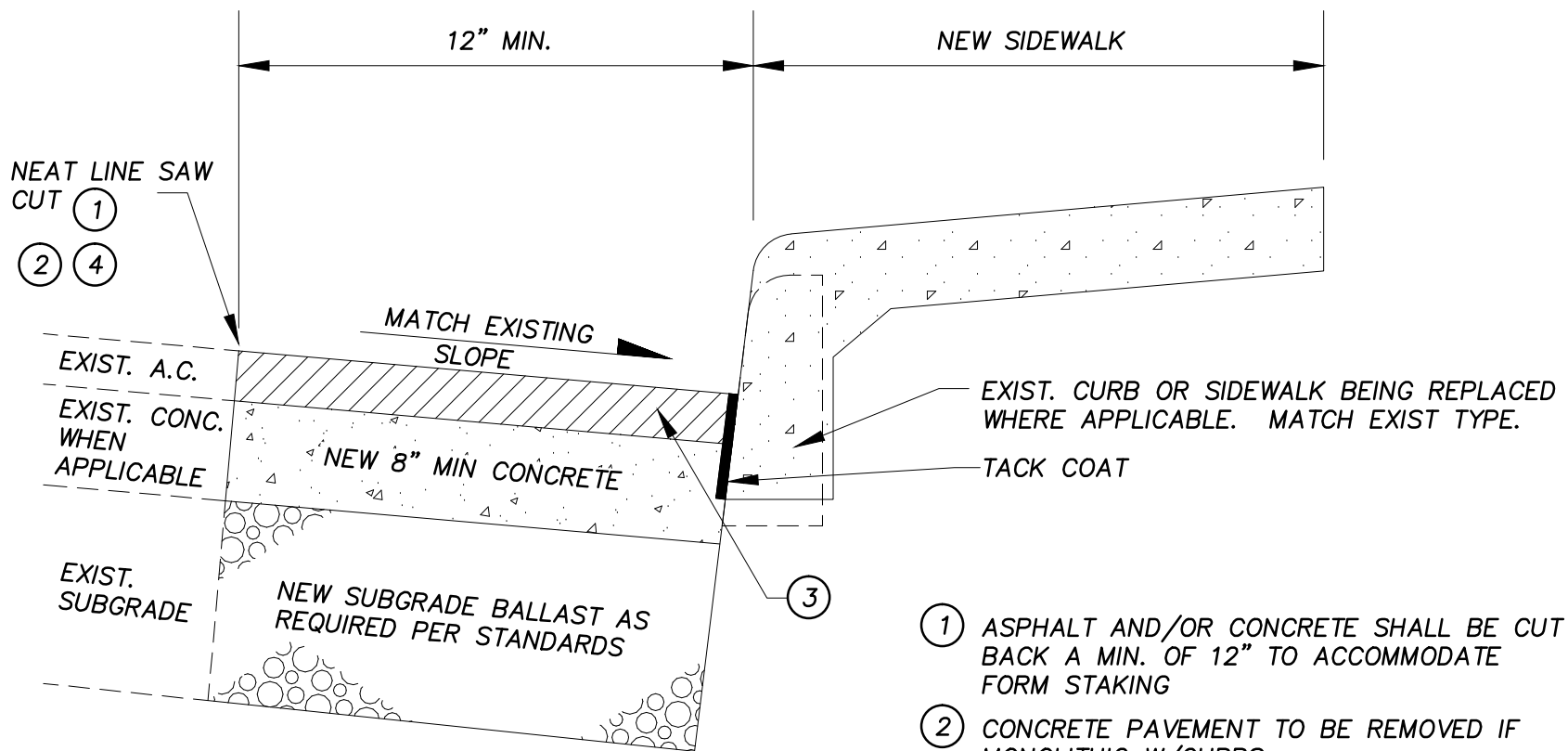

- ① ASPHALT AND/OR CONCRETE SHALL BE CUT BACK A MIN. OF 12" TO ACCOMMODATE FORM STAKING
- ② CONCRETE PAVEMENT TO BE REMOVED IF MONOLITHIC W/CURBS
- ③ MIN. OF 3" A.C. ON LOCAL & COLLECTOR
4" A.C. ON ARTERIAL
- ④ SEAL EDGES WITH EMULSIFIED ASPHALT GRADE CSS-1 TACK. ALL JOINTS SHALL BE SEALED USING PAVING ASPHALT AR4000W.

APPROVED BY	REVISED DATE	CITY OF OLYMPIA REPLACEMENT OF EXISTING CURB AND/OR SIDEWALK TYPICAL PAVEMENT PATCHING	STD. PLAN NO.
	7/7/06		4-14D
CITY ENGINEER			

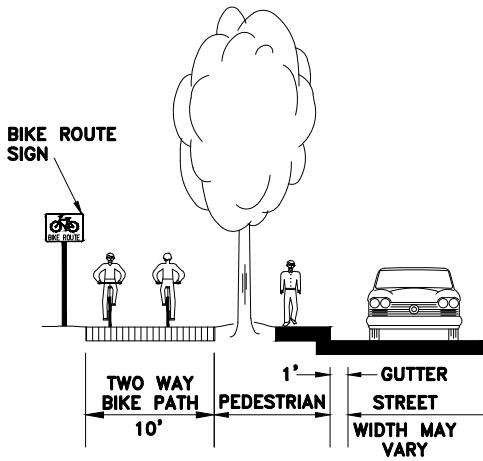

CLASS I BIKE PATH

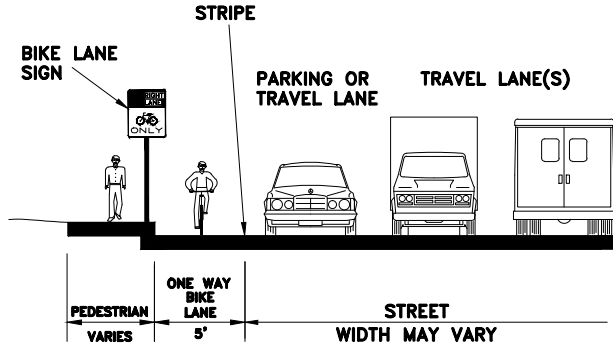

CLASS II BIKE LANE

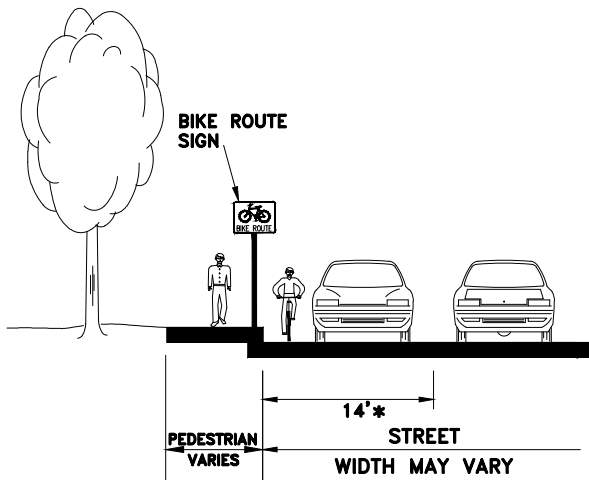

CLASS III BIKE ROUTE

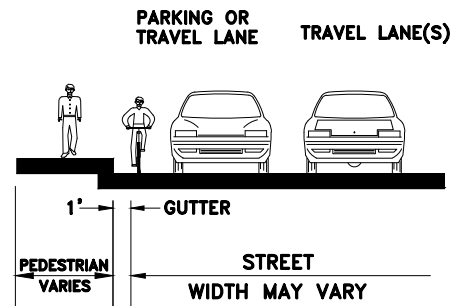

CLASS IV SHARED ROADWAY

* WIDEN VEHICLE TRAVEL LANE

APPROVED BY	REVISED DATE	CITY OF OLYMPIA	STD. PLAN NO.
CITY ENGINEER	12/12/06	BIKEWAY CLASSES	4-16

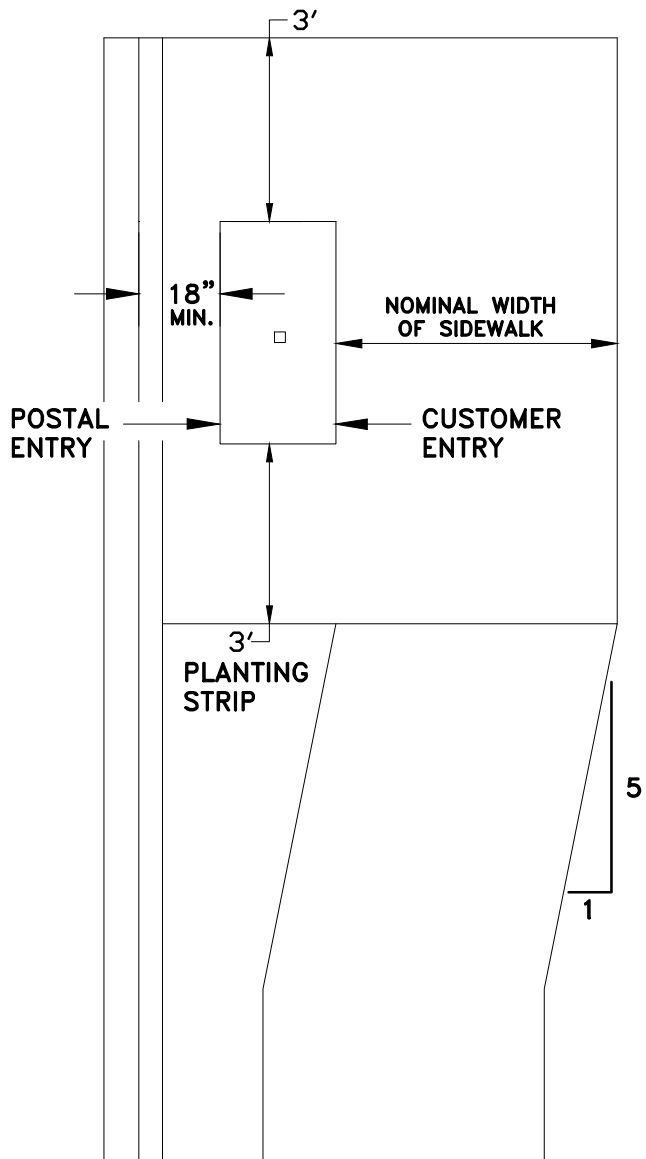
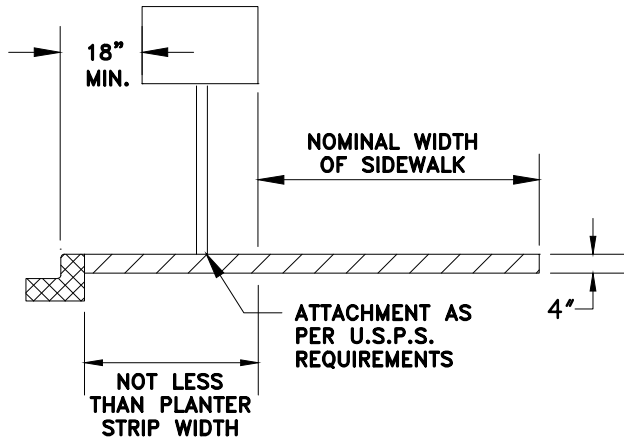

GENERAL NOTES:

1. SEE DEVELOPMENT GUIDELINE 4G.070 FOR ADDITIONAL REQUIREMENTS.
2. LOCATE OUTSIDE INTERSECTION SIGHT-DISTANCE OBSTRUCTION AREAS.

APPROVED BY	REVISED DATE	CITY OF OLYMPIA	STD. PLAN NO.
	12/04/92	MAIL BOX CLUSTER	4-18
CITY ENGINEER			

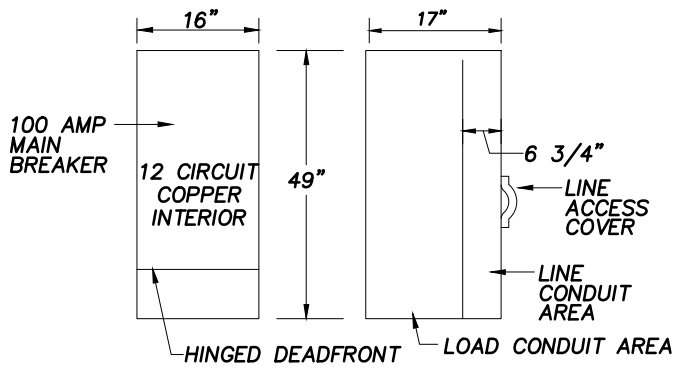

MILBANK CP3B-11C15AALSP2

OR APPROVED EQUAL

THE UNIT SHALL CONTAIN THE FOLLOWING
 ADDITIONAL EQUIPMENT:
 MECHANICAL CONTACTOR FOR EACH STREETLIGHT CIRCUIT
 ONE TEST SWITCH
 ONE PHOTOCELL
 5TH JAW IN 9 O'CLOCK POSITION
 THE UNIT SHALL BE SET UP TO ACCEPT:
 ONE TIME CLOCK

SPECIFICATIONS

1. STANDARD VOLTAGE IS 120/240V 1Ø3W
2. CALTRANS TYPE 3B SERVICE OR U.L. APPROVED EQUAL.
3. TYPE 3R RAINPROOF ENCLOSURE
4. ALUMINUM ANNOXIDIZED CONSTRUCTION.
5. INTERIORS WILL ACCEPT PLUG-IN BREAKERS (BRYANT, G.E., WESTINGHOUSE, ITE, CROUSE-HINDS)
6. DETACHABLE PADMOUNT SUB-BASE
7. COPPER BUSSED INTERIOR HAS PROVISIONS FOR TWELVE FULL ONE-INCH POLES.
8. SUITABLE FOR USE WITHOUT A MAIN WHEN NO MORE THAN SIX SERVICE DISCONNECTS ARE INSTALLED AND USED IN ACCORDANCE WITH ARTICLE 384 OF THE NEC.

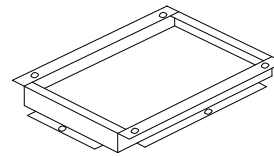

PADMOUNT BASE BEFORE INSTALLATION ON OR IN CONCRETE FOUNDATION

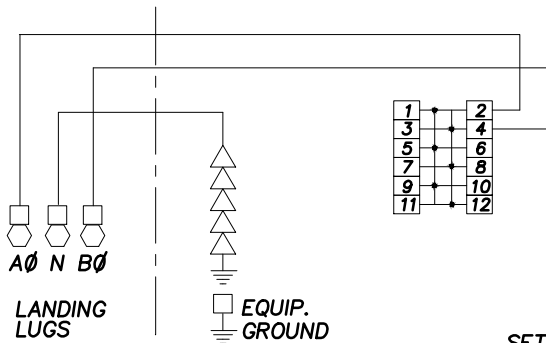

WIRING DIAGRAM

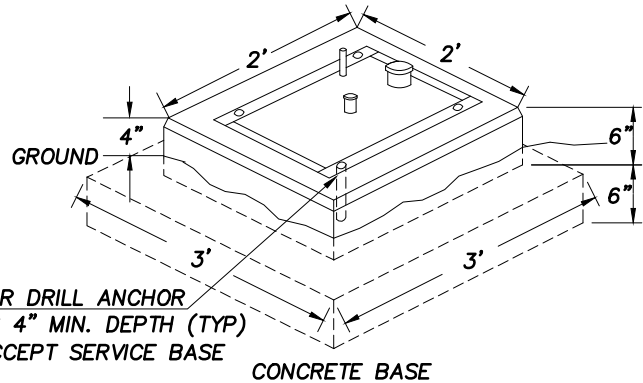

CONCRETE BASE

FOUNDATION

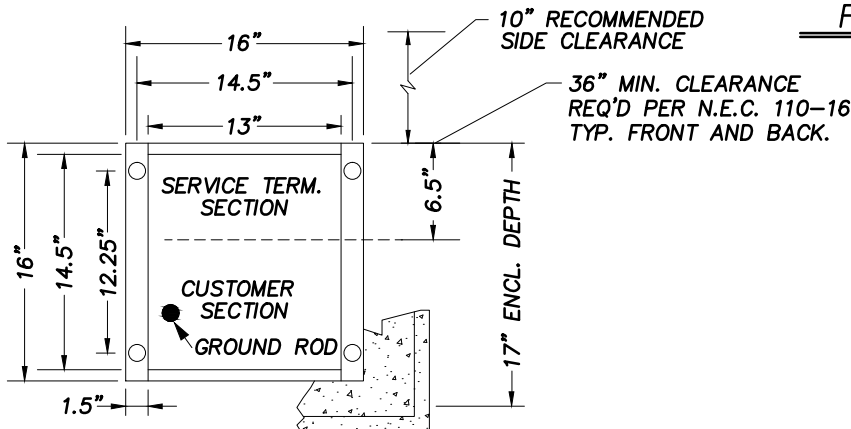

FLOOR PLAN

APPROVED BY	REVISED DATE	CITY OF OLYMPIA	STD. PLAN NO.
CITY ENGINEER	3/22/2011	SERVICE DISCONNECT FOR STREETLIGHTS & TRAFFIC SIGNALS	4-19

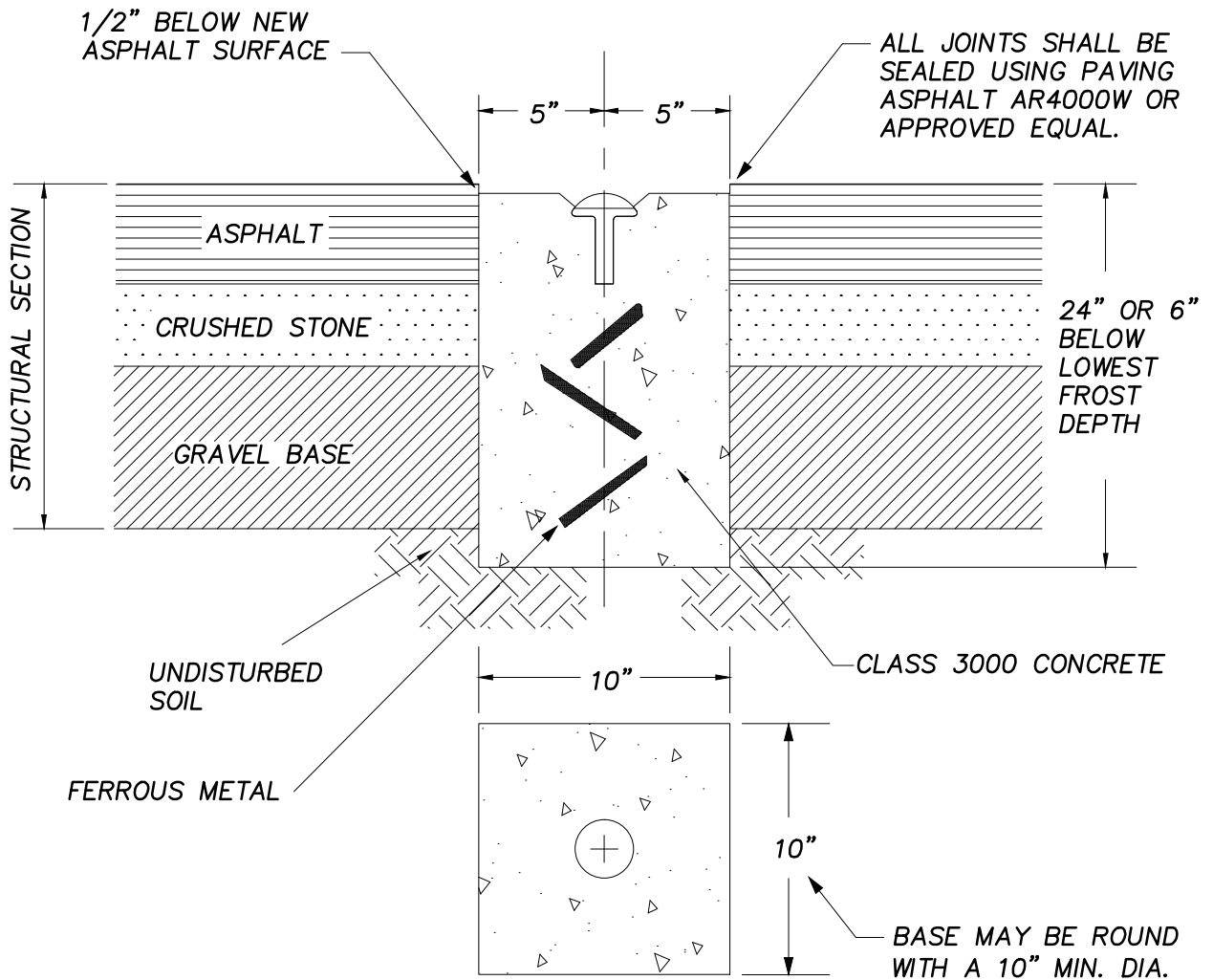

GENERAL NOTES:

1. THIS MONUMENT TO BE USED PRIMARILY IN BITUMINOUS OR ASPHALT CONCRETE PAVEMENT AND CENTERLINE MEDIAN LANDSCAPED AREAS. PRIMARILY USED IN SUBDIVISIONS AND MINOR ARTERIALS.
2. CONCRETE BASE DIMENSIONS SHOWN ARE MINIMUM. CONCRETE BASE NEED NOT BE FORMED.
3. CAP SHALL BE A 2" OR LARGER BRASS PLUG MARKER.
4. CONCRETE TO BE PLACED ON A FIRM AND UNYIELDING FOUNDATION.
5. TOP OF CONCRETE SHALL BE TROWELLED SMOOTH WITH THE BRASS DISC SET IN CENTER AND LEVEL. THE BRASS DISC SHALL BE RECESSED TO PREVENT DAMAGE FROM VEHICLES AND MAINTENANCE EQUIPMENT.
6. THE LETTERING ON THE BRASS DISC SHALL BE ORIENTED NORTH.
7. THE CORNER MARK "X" OR HOLE PUNCH SHALL BE WITHIN 1/2" OF DISC CENTER.
8. ALL CONSTRUCTION AND MATERIALS SHALL MEET THE SPECIFICATIONS AND BE APPROVED BY THE CITY ENGINEER.

APPROVED BY	REVISED DATE	CITY OF OLYMPIA	STD. PLAN NO.
	10/10/2011	POURED IN PLACE MONUMENT	4-20
CITY ENGINEER			

MONUMENTS IN UNPAVED AREAS ARE NOT REQUIRED TO BE SET PER THIS DETAIL.

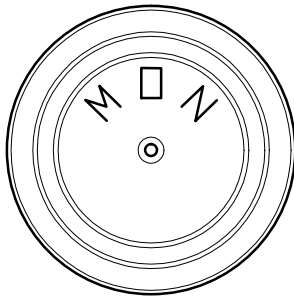

PLAN VIEW

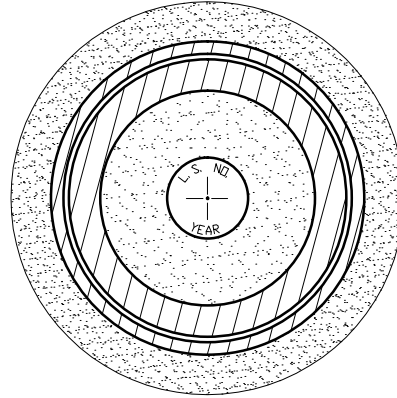

PLAN VIEW

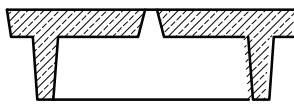

CROSS SECTION VIEW
MONUMENT COVER

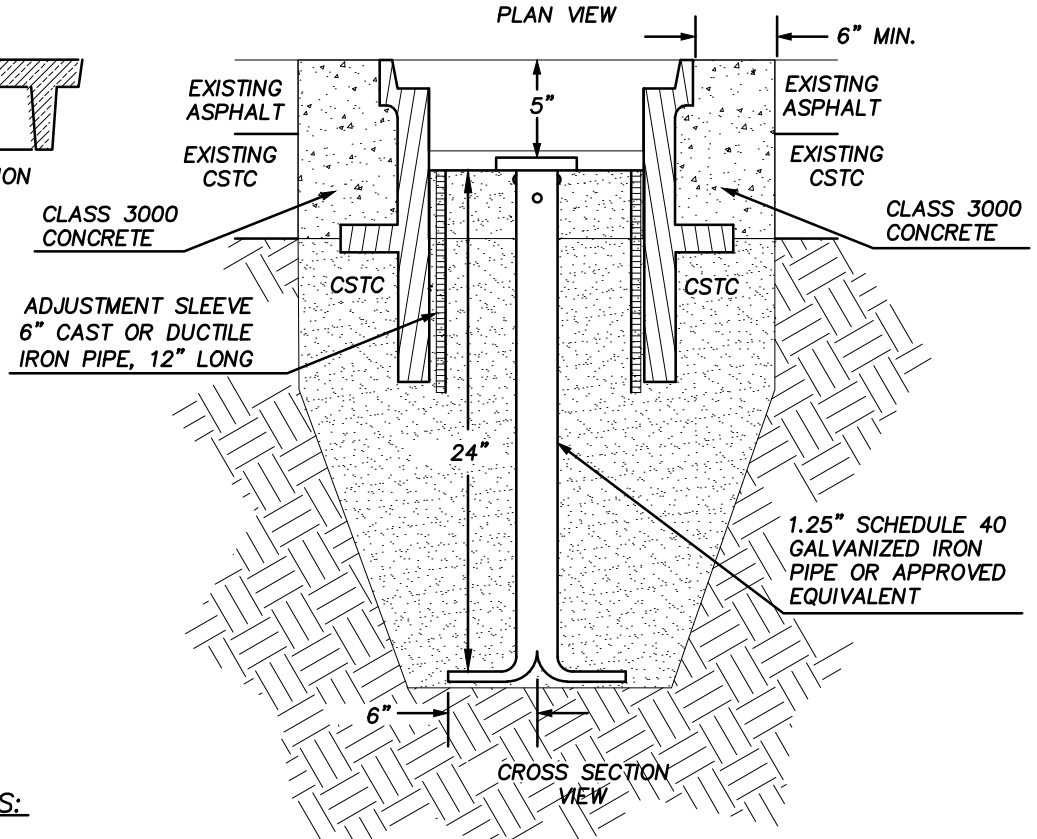

GENERAL NOTES:

1. THIS MONUMENT TO BE USED PRIMARILY IN COLLECTORS AND MAJOR ARTERIALS.
2. BRASS OR ALUMINUM CAP SHALL BE 2" OR LARGER.
3. AREA EXCAVATED TO INSTALL MONUMENT SHALL BE BACKFILLED WITH CSTC TO WITHIN 9 INCHES OF FINISHED GRADE (THE BOTTOM OF THE MONUMENT CASE) AND COMPACTED TO 95% OF MAXIMUM DENSITY. THE VOID INSIDE THE MONUMENT CASE SHALL ALSO BE FILLED WITH CSTC TO THE BOTTOM OF THE BRASS/ALUMINUM CAP.
4. ADJUST MONUMENT CASE IN ASPHALT TO 1/4 INCH BELOW FINISH GRADE.
5. "MON" SHALL BE CAST INTO THE LID.
6. THE LETTERING ON THE BRASS DISC SHALL BE ORIENTED NORTH.
7. THE CORNER MARK "X" OR HOLE PUNCH SHALL BE WITHIN 1/2" OF DISC CENTER.
8. ALL CONSTRUCTION AND MATERIALS SHALL MEET THE SPECIFICATIONS AND BE APPROVED BY THE CITY ENGINEER.

APPROVED BY	REVISED DATE	CITY OF OLYMPIA	STD. PLAN NO.
CITY ENGINEER	10/10/2011	CASE MONUMENT	4-23A

MONUMENTS IN UNPAVED AREAS ARE NOT REQUIRED TO BE SET PER THIS DETAIL.

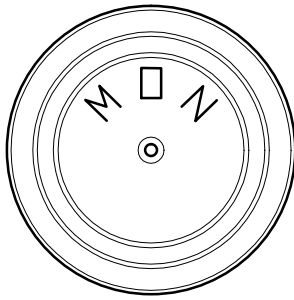

PLAN VIEW

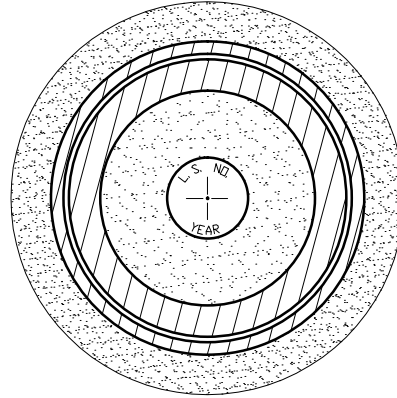

PLAN VIEW

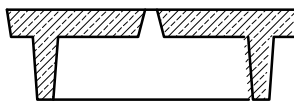

CROSS SECTION VIEW
MONUMENT COVER

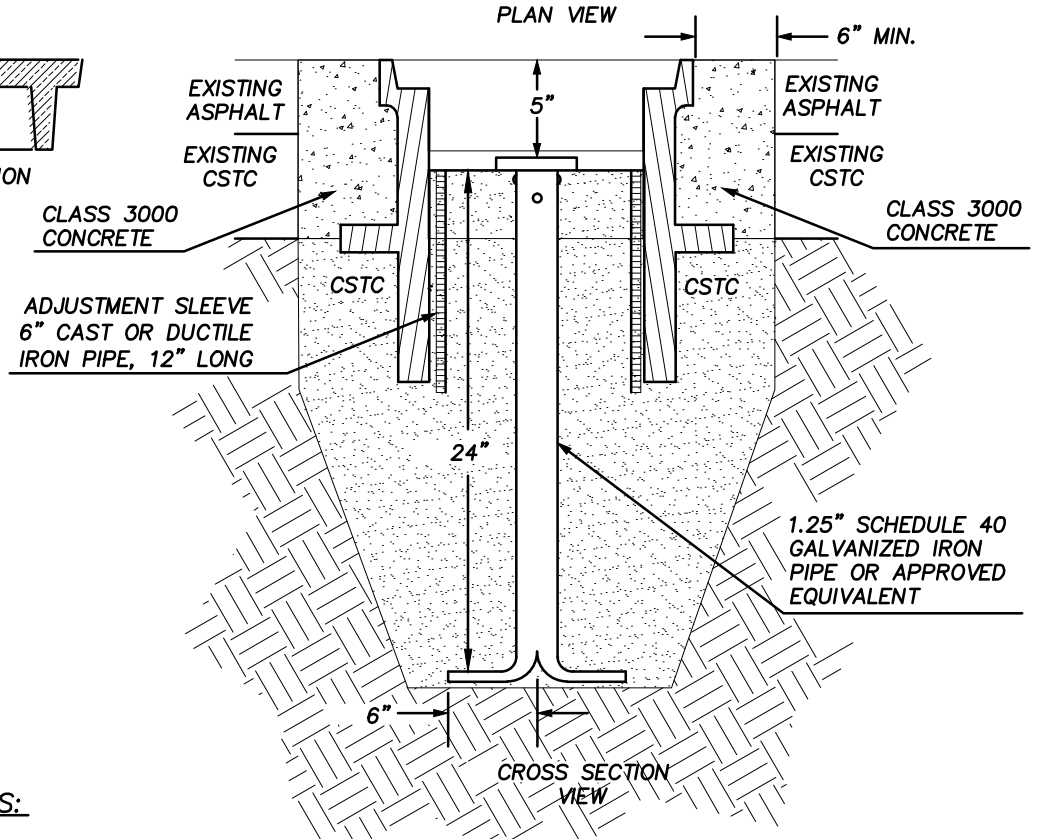

GENERAL NOTES:

1. THIS MONUMENT TO BE USED PRIMARILY IN COLLECTORS AND MAJOR ARTERIALS.
2. BRASS OR ALUMINUM CAP SHALL BE 2" OR LARGER.
3. AREA EXCAVATED TO INSTALL MONUMENT SHALL BE BACKFILLED WITH CSTC TO WITHIN 9 INCHES OF FINISHED GRADE (THE BOTTOM OF THE MONUMENT CASE) AND COMPACTED TO 95% OF MAXIMUM DENSITY. THE VOID INSIDE THE MONUMENT CASE SHALL ALSO BE FILLED WITH CSTC TO THE BOTTOM OF THE BRASS/ALUMINUM CAP.
4. ADJUST MONUMENT CASE IN ASPHALT TO 1/4 INCH BELOW FINISH GRADE.
5. "MON" SHALL BE CAST INTO THE LID.
6. THE LETTERING ON THE BRASS DISC SHALL BE ORIENTED NORTH.
7. THE CORNER MARK "X" OR HOLE PUNCH SHALL BE WITHIN 1/2" OF DISC CENTER.
8. ALL CONSTRUCTION AND MATERIALS SHALL MEET THE SPECIFICATIONS AND BE APPROVED BY THE CITY ENGINEER.

APPROVED BY	REVISED DATE	CITY OF OLYMPIA	STD. PLAN NO.
CITY ENGINEER	10/10/2011	CASE MONUMENT	4-23A

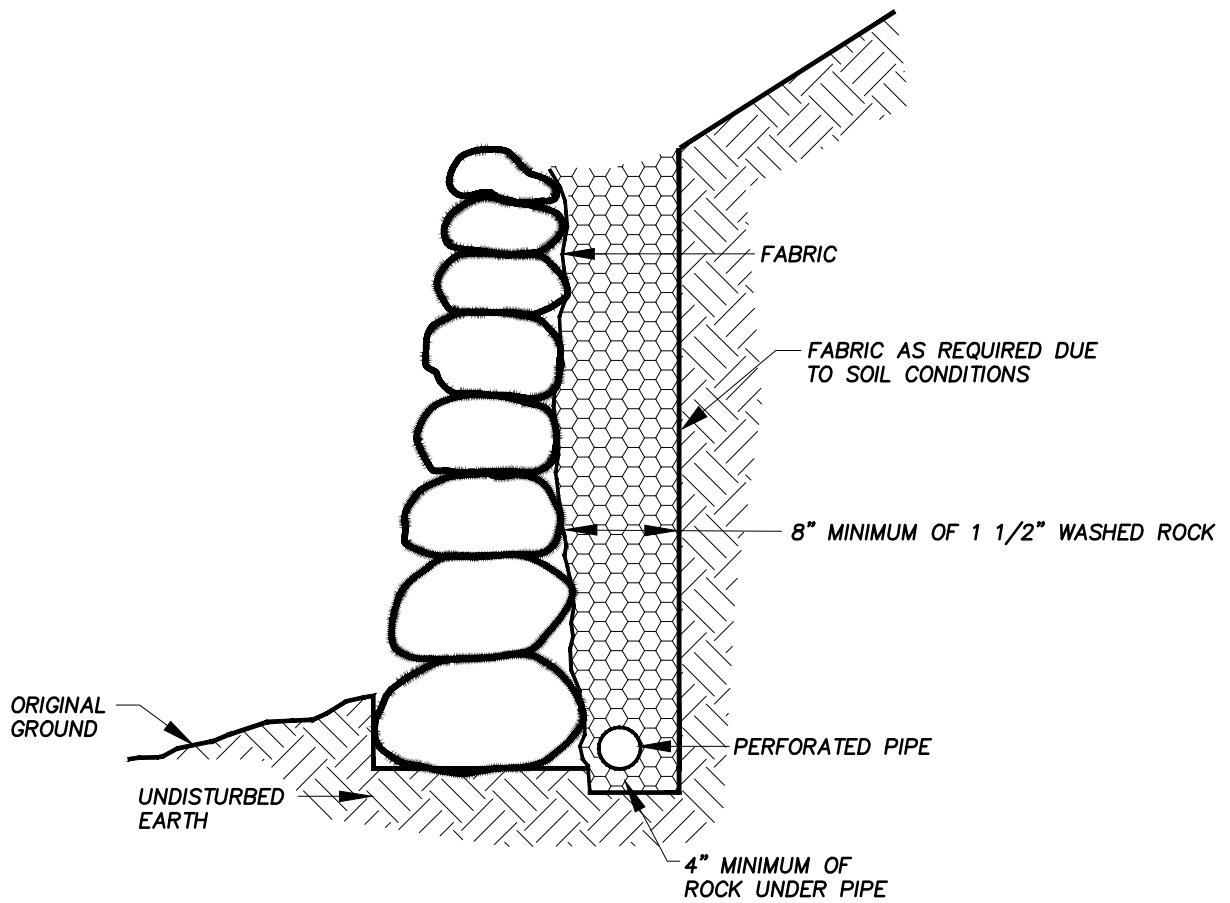

NOTE:

DESIGN FOR ROCK RETAINING WALL AND DRAINAGE SYSTEM, INCLUDING PERFORATED PIPE DIAMETER, SHALL CARRY THE SEAL OF CIVIL ENGINEER EXPERIENCED IN SOIL MECHANICS.

APPROVED BY	REVISED DATE	CITY OF OLYMPIA	STD. PLAN NO.
	6/07/2012	ROCK RETAINING WALL DRAINAGE	4-26
CITY ENGINEER			

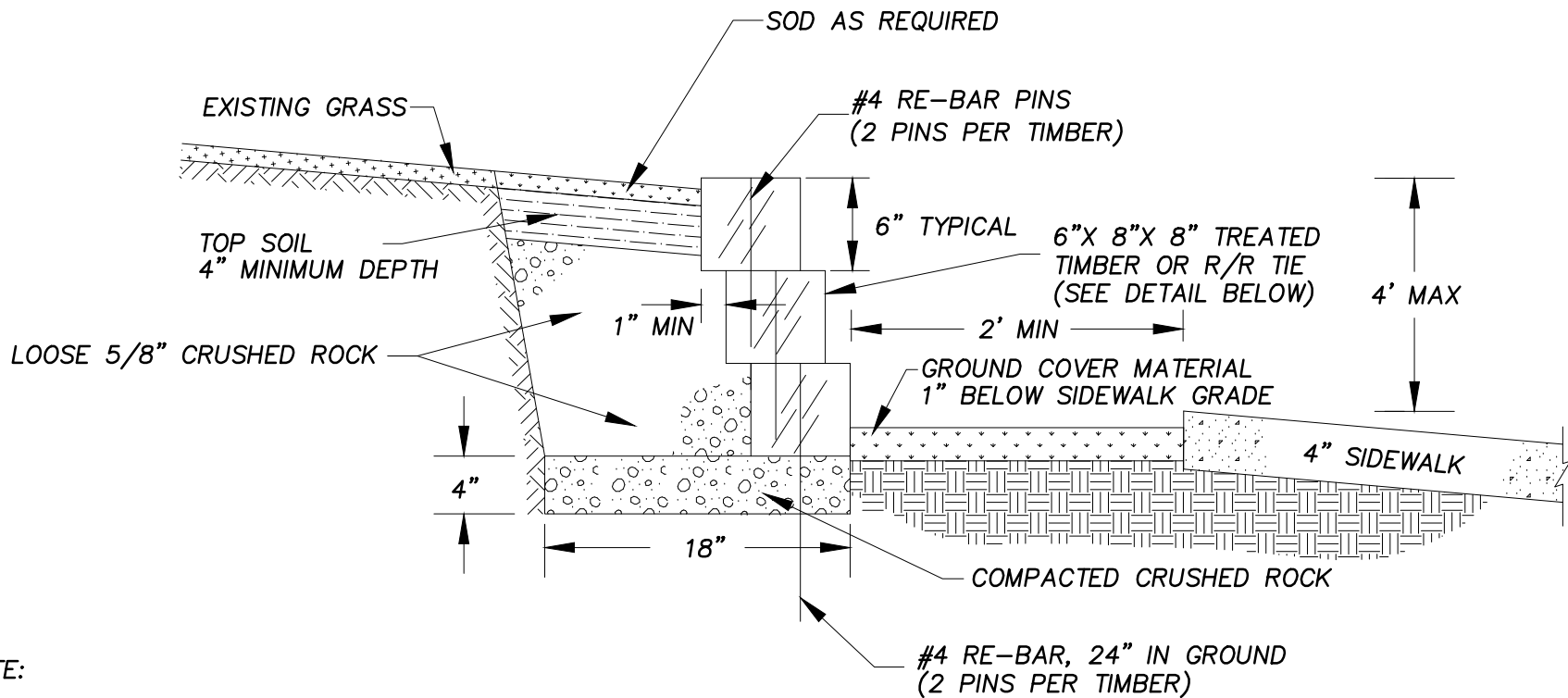

NOTE:

- PRE DRILL ALL RE-BAR HOLES
- SIMILAR DESIGN SHALL BE USED WHEN GROUND ELEVATION IS LOWER THAN BACK OF SIDEWALK.

TIMBER DETAIL:

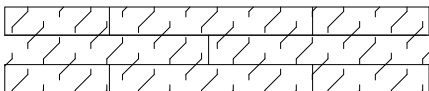

APPROVED BY	REVISED DATE	CITY OF OLYMPIA	STD. PLAN NO.
	7/18/06	LANDSCAPE TIMBERS	4-26A
CITY ENGINEER			

TYPICAL CENTERLINE PAVEMENT MARKING DETAIL

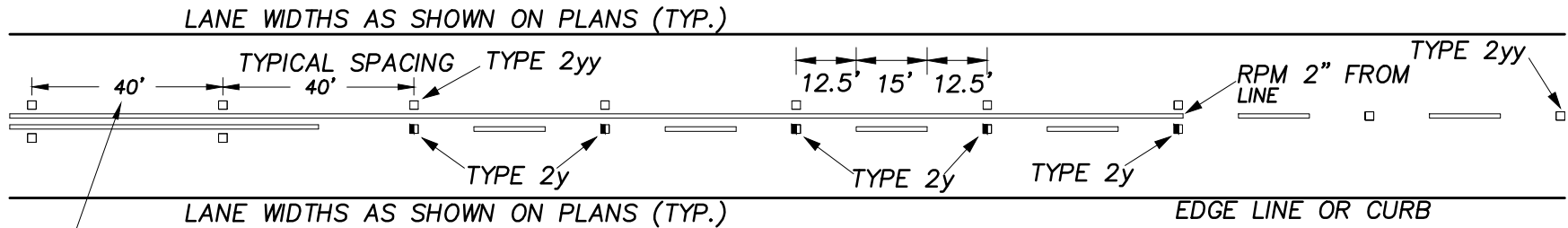

SEE NOTE 2 FOR RPM SPACING ON CURVE.

TYPICAL LANE STRIPING

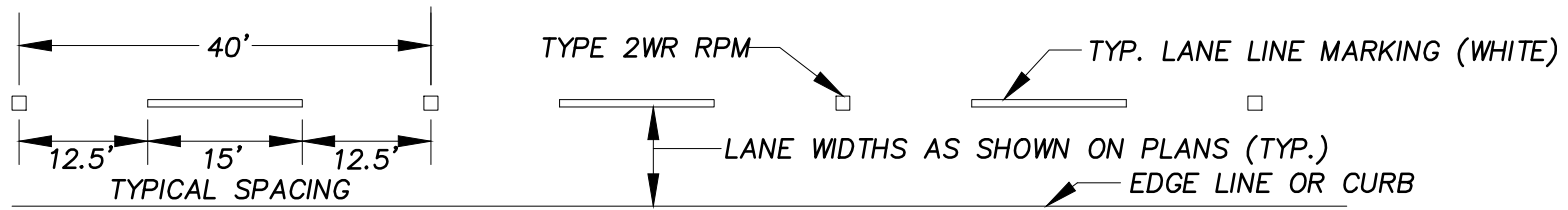

NOTES:

1. RAILROAD CROSSING MARKINGS, WHERE APPLICABLE, SHALL CONFORM TO THE MUTCD AND WSDOT STANDARD PLAN M-11.10-01. THE "STANDARD SYMBOL" SHALL BE USED.
2. RAISED PAVEMENT MARKERS (RPM) TYPES 2YY, 2Y AND 2WR SHALL BE SPACED AT 20 FOOT INTERVALS ON HORIZONTAL CURVES OF RADIUS 1000 FEET OR LESS, OR AS DIRECTED BY THE ENGINEER.

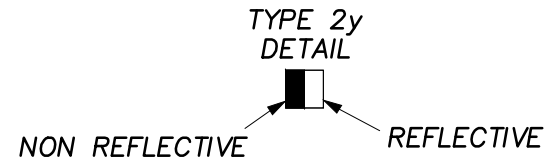

APPROVED BY	REVISED DATE	CITY OF OLYMPIA	STD. PLAN NO.
CITY ENGINEER	9/26/2011	STRIPING DETAIL	4-27A

TYPICAL RIGHT TURN LANE STRIPING

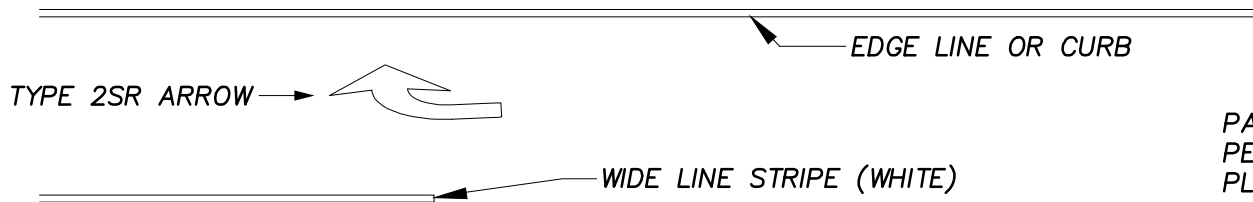

PAVEMENT WORDS AND SYMBOLS PER M.U.T.C.D. AND SHALL BE PLASTIC.

TYPICAL LEFT TURN LANE STRIPING

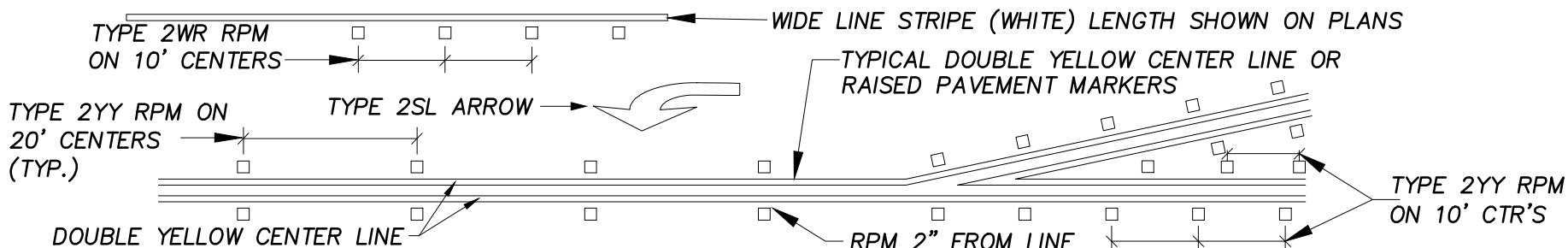

TRAFFIC ARROW PLACEMENT

TURN LANE LENGTH (L)	DISTANCE FROM STOP LINE OR CROSSWALK (FEET)			
	FIRST ARROW	SECOND ARROW	THIRD ARROW	FOURTH ARROW
UP TO 75 FT.	L	N/A	N/A	N/A
>75 FT. & UP TO 150 FT.	50	L	N/A	N/A
>150 FT. & UP TO 250 FT.	50	$50+(L-50)/2$	L	N/A
>250 FT. & UP TO 350 FT.	50	$50+(L-50)/3$	$50+2(L-50)/3$	L

INSTALL "ONLY" IF DIRECTED BY ENGINEER.

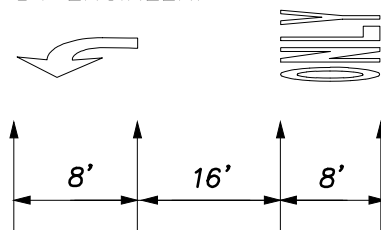

(TYP)

NOTE: RAILROAD CROSSING MARKINGS SHALL CONFORM TO THE M.U.T.C.D. AND W.S.D.O.T. STANDARD PLAN H-5C.

APPROVED BY	REVISED DATE	CITY OF OLYMPIA	STD. PLAN NO.
	3/22/2011	STRIPING DETAIL	4-27B
CITY ENGINEER			

TWO WAY LEFT TURN LANE

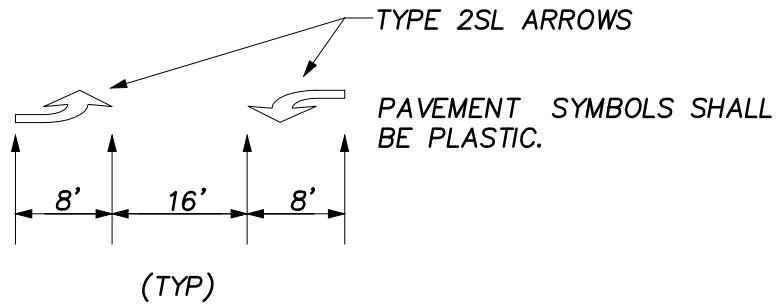
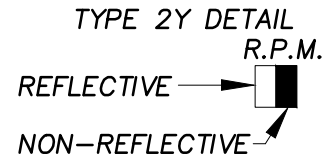
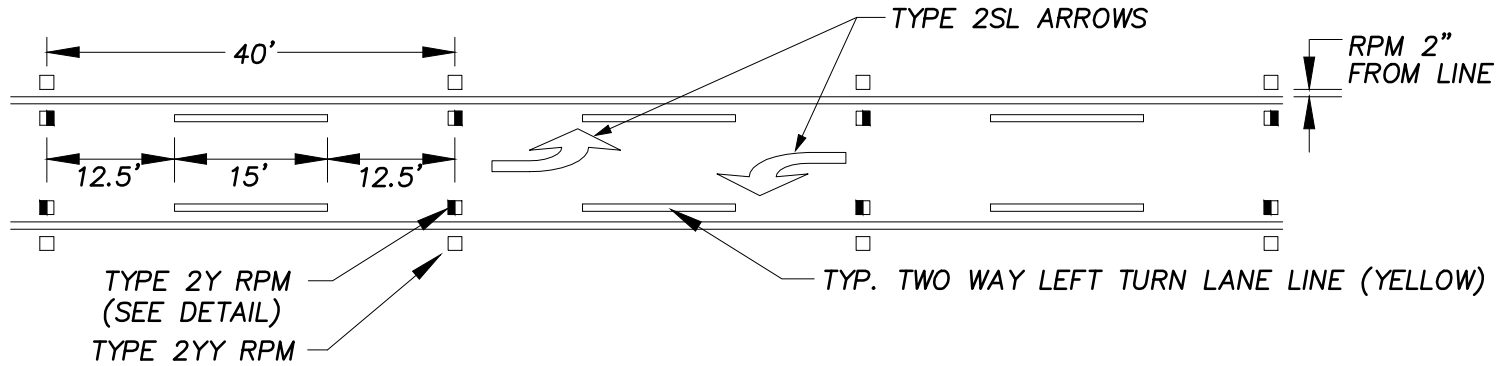

TWO WAY TURN LANE ARROW PLACEMENT
 1) 50 FT. FROM START AND END OF LANE.
 NUMBER OF ARROWS IN BETWEEN SHALL BE
 DETERMINED BY $\frac{\text{TOTAL LANE DISTANCE} - 100}{300}$

2) ARROWS SHALL BE EVENLY SPACED.

NOTES: RAILROAD CROSSING
 MARKINGS SHALL CONFORM TO
 MANUAL ON UNIFORM TRAFFIC
 CONTROL DEVICES (M.U.T.C.D.)

APPROVED BY	REVISED DATE	CITY OF OLYMPIA	STD. PLAN NO.
CITY ENGINEER	2/09/09	STRIPING DETAIL	4-27C

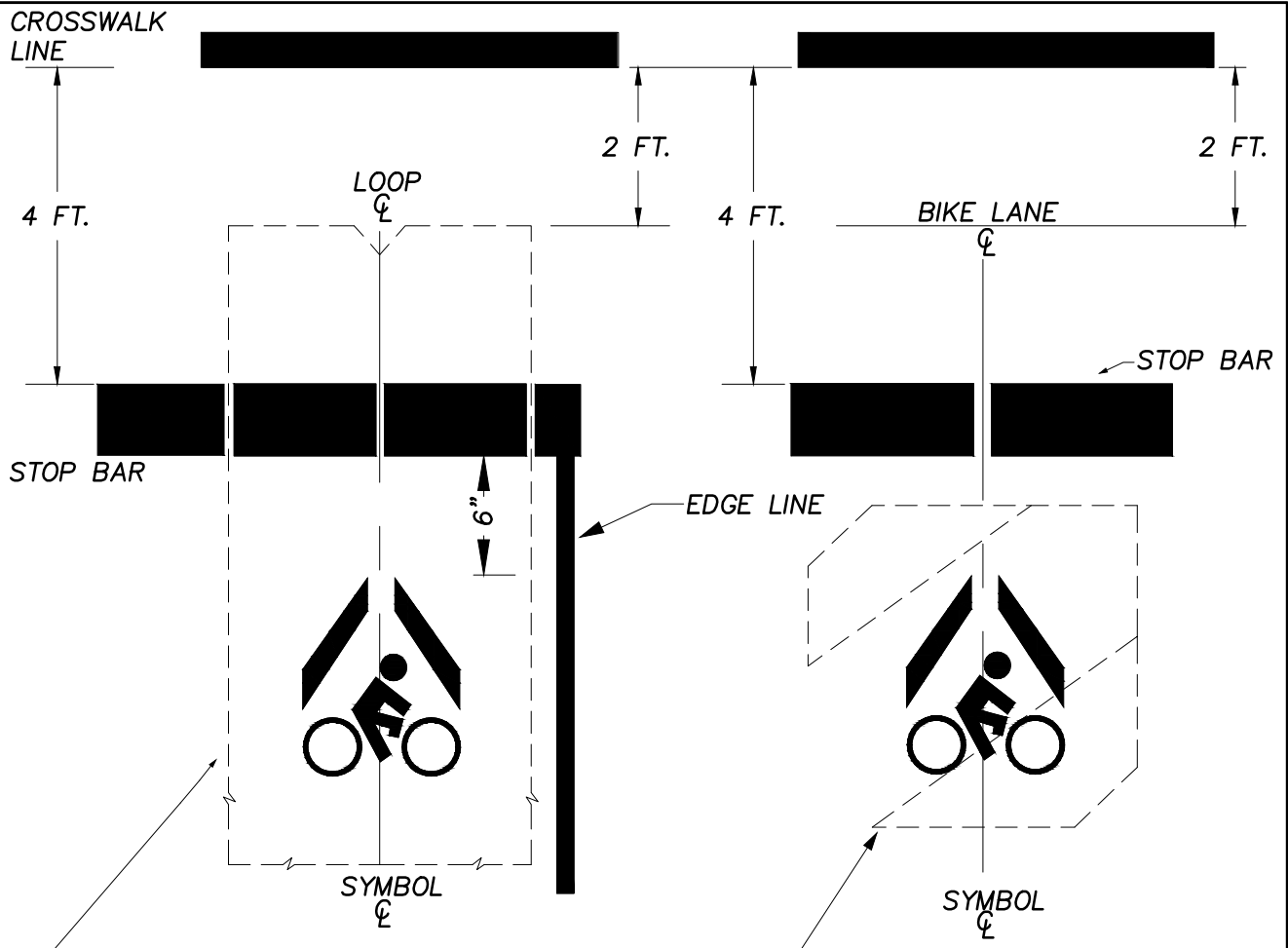

TYPE 1 BIKE LOOP
 NOTE: PLACE SYMBOL 6" FROM STOP BAR. IF NO STOP BAR PLACE 2 1/2' FROM CROSSWALK LINE.

TYPE "D" LOOP FOR BIKE LANE
 NOTE: PLACE SYMBOL 6" FROM STOP BAR. IF NO STOP BAR PLACE 6" FROM CROSSWALK LINE.

CYCLE DETECTOR SYMBOL LOCATION

STOP BAR: INSTALL STOP BAR ONLY IF SHOWN ON STRIPING PLANS OR IF DIRECTED BY THE ENGINEER.

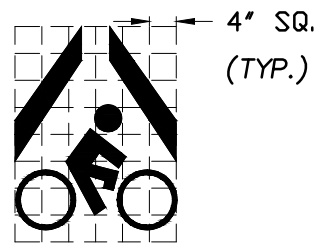

CYCLE DETECTOR SYMBOL

APPROVED BY	REVISED DATE	CITY OF OLYMPIA	STD. PLAN NO.
	7/24/06	CYCLE DETECTOR SYMBOLS	4-27D
CITY ENGINEER			

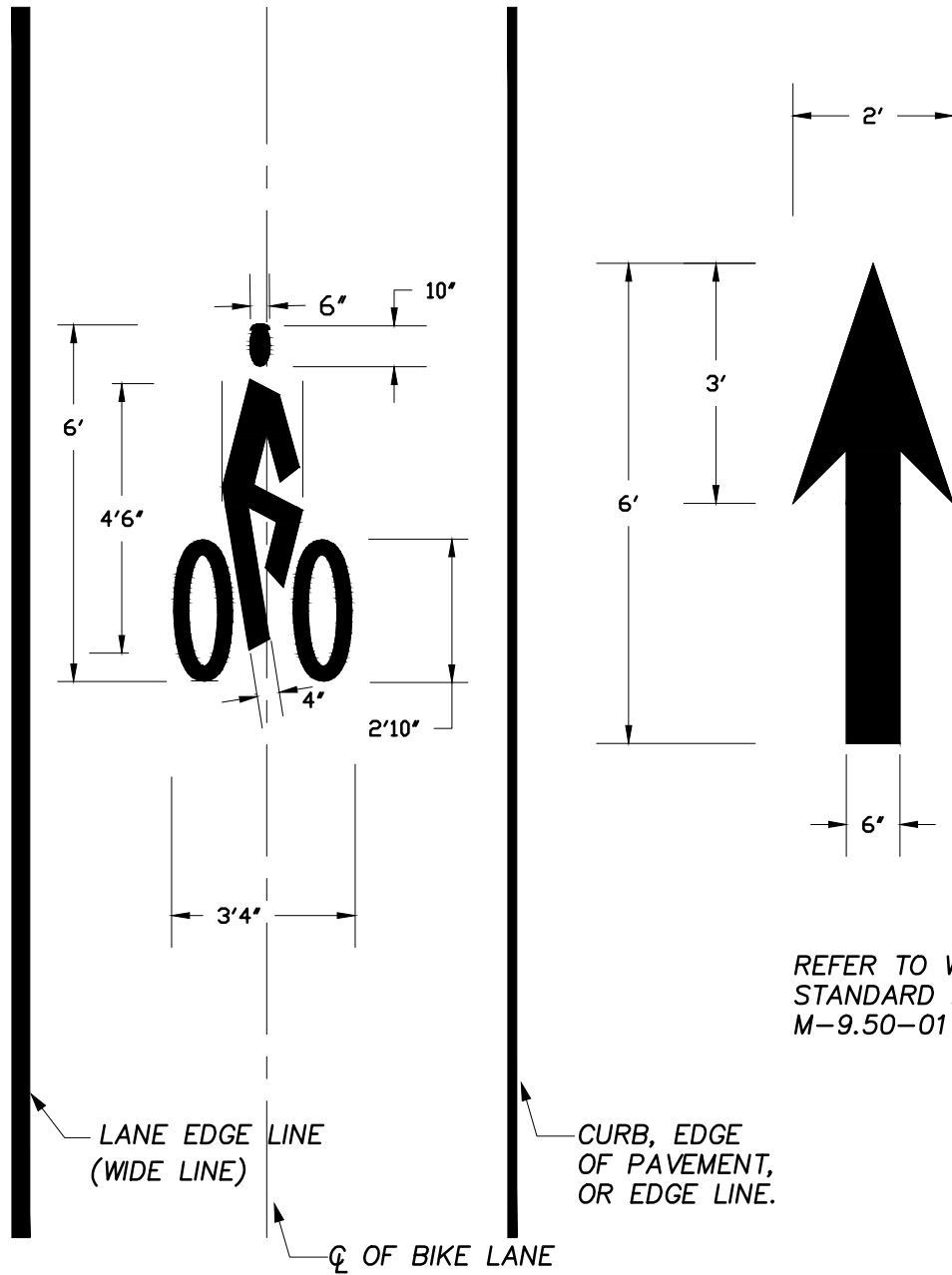

REFER TO WSDOT
STANDARD PLAN
M-9.50-01

TYPICAL BICYCLE LEGEND LAYOUT

BICYCLE LEGEND:
THE BICYCLE LEGEND CONSISTS OF
ONE- (6) FOOT-HIGH ARROW
INDICATING THE DIRECTION OF TRAVEL,
ONE- (6) FOOT-HIGH BICYCLE SYMBOL.

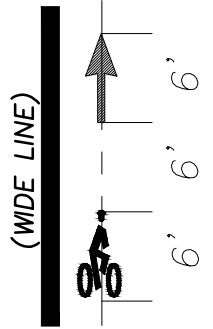

N. T. S.

APPROVED BY	REVISED DATE	CITY OF OLYMPIA	STD. PLAN NO.
	2/26/08	DESIGNATED BICYCLE LANE SYMBOL	4-27E
CITY ENGINEER			

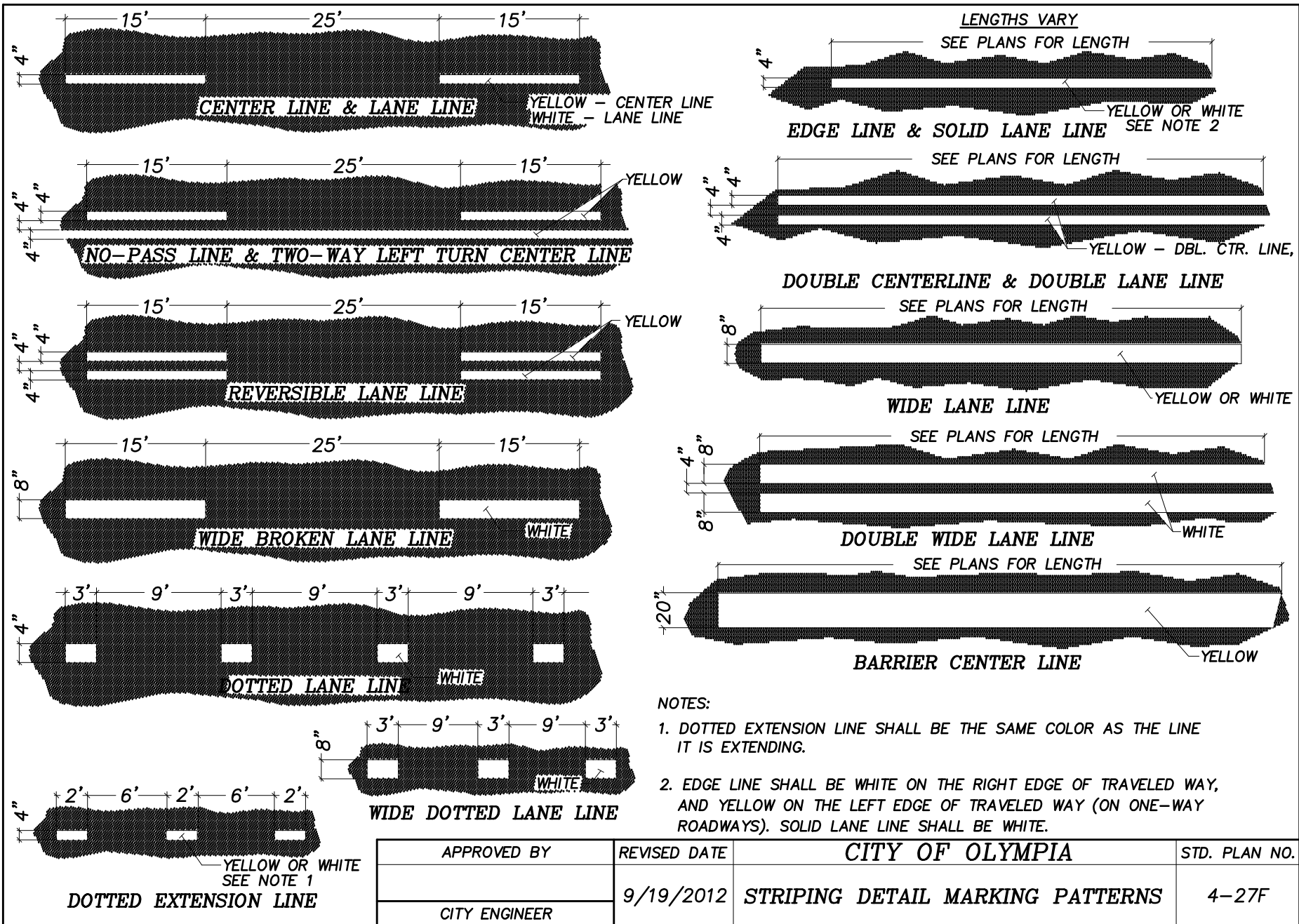

NOTES:

1. DOTTED EXTENSION LINE SHALL BE THE SAME COLOR AS THE LINE IT IS EXTENDING.
2. EDGE LINE SHALL BE WHITE ON THE RIGHT EDGE OF TRAVELED WAY, AND YELLOW ON THE LEFT EDGE OF TRAVELED WAY (ON ONE-WAY ROADWAYS). SOLID LANE LINE SHALL BE WHITE.

APPROVED BY	REVISED DATE	CITY OF OLYMPIA	STD. PLAN NO.
CITY ENGINEER	9/19/2012	STRIPING DETAIL MARKING PATTERNS	4-27F

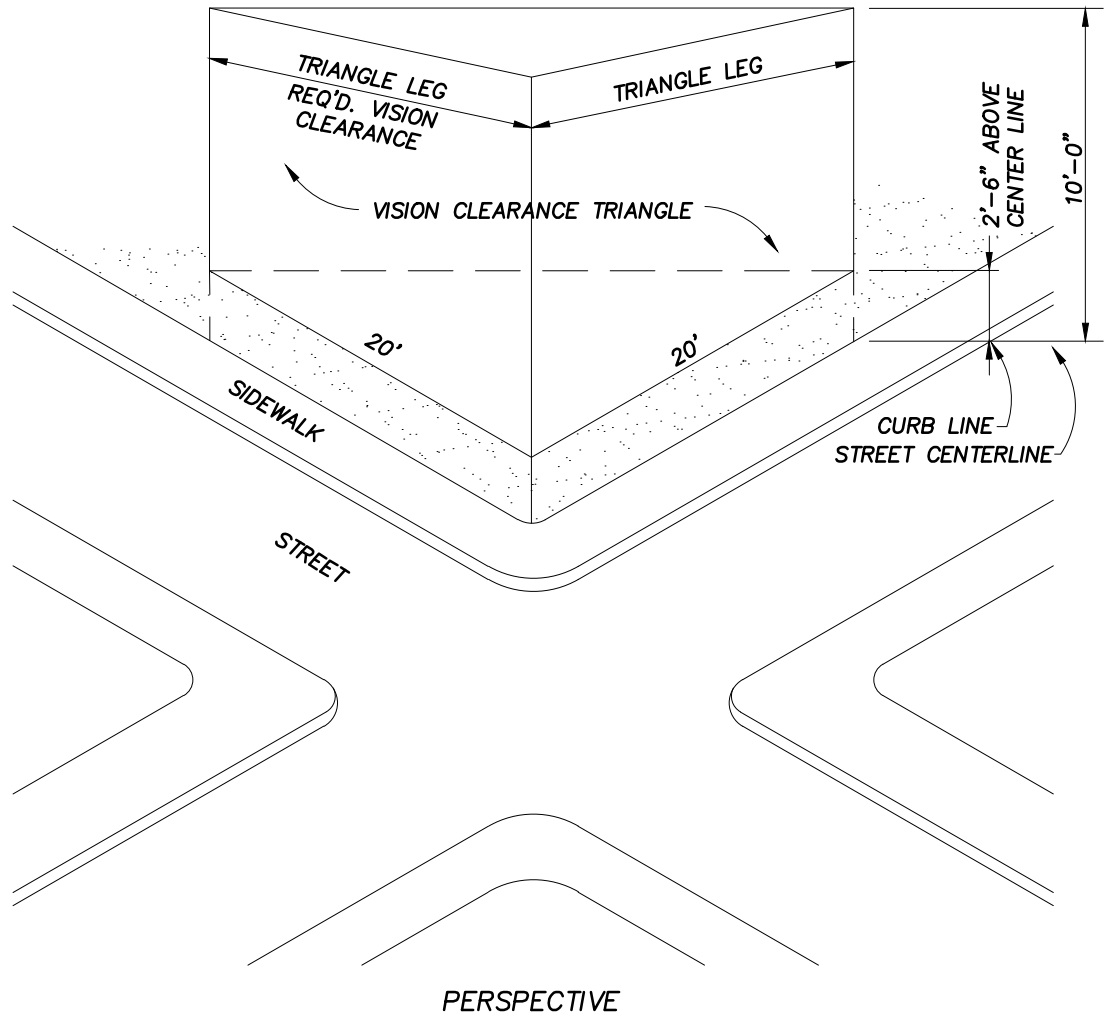
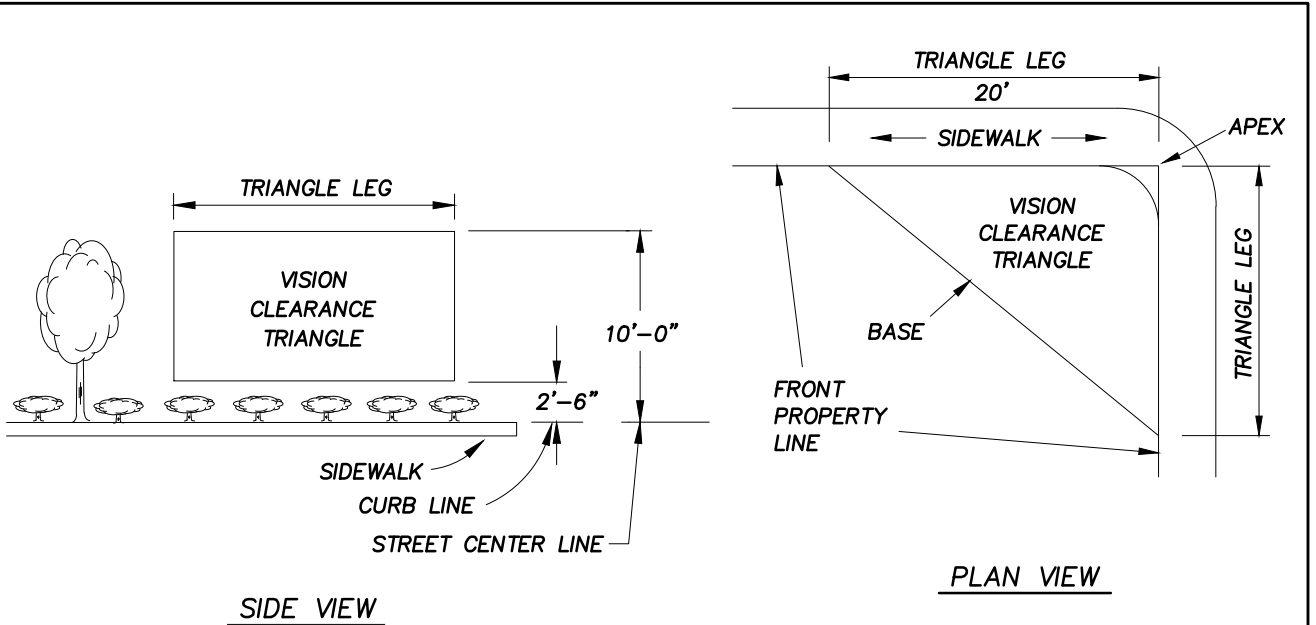

APPROVED BY	REVISED DATE	CITY OF OLYMPIA	STD. PLAN NO.
CITY ENGINEER	1/15/93	VISION CLEARANCE TRIANGLE	4-29

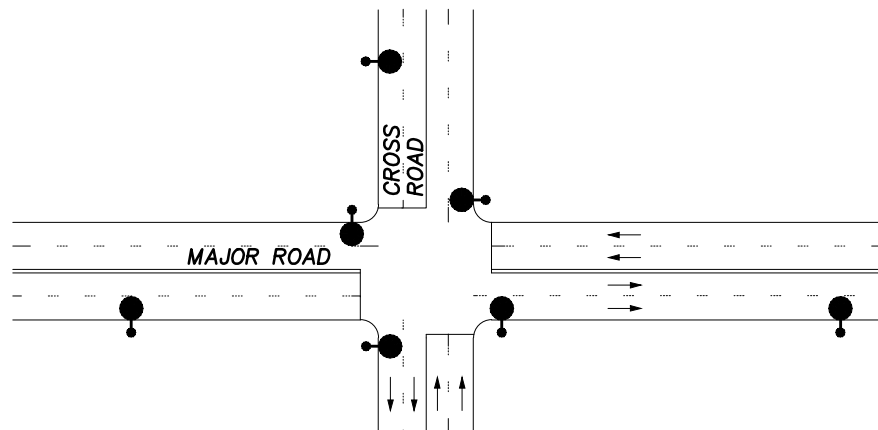
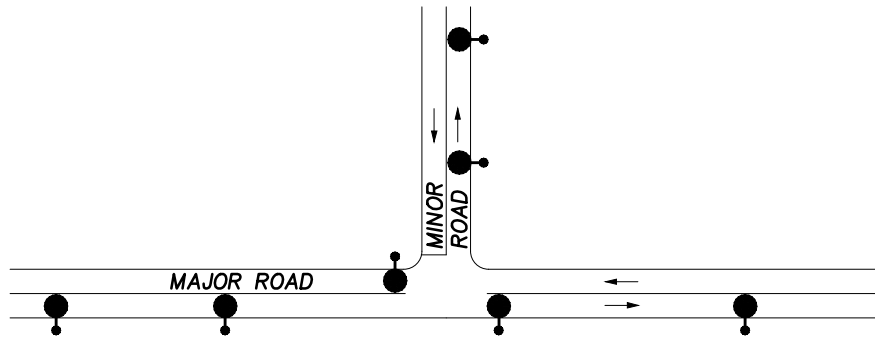
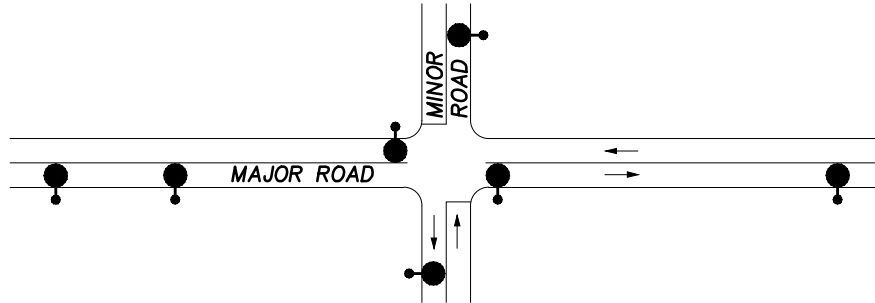
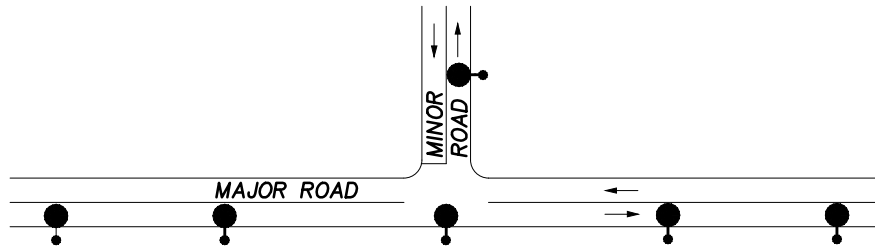

APPROVED BY	REVISED DATE	CITY OF OLYMPIA	STD. PLAN NO.
	4/21/97	TYPICAL STREET LIGHT LAYOUTS	4-30
CITY ENGINEER			

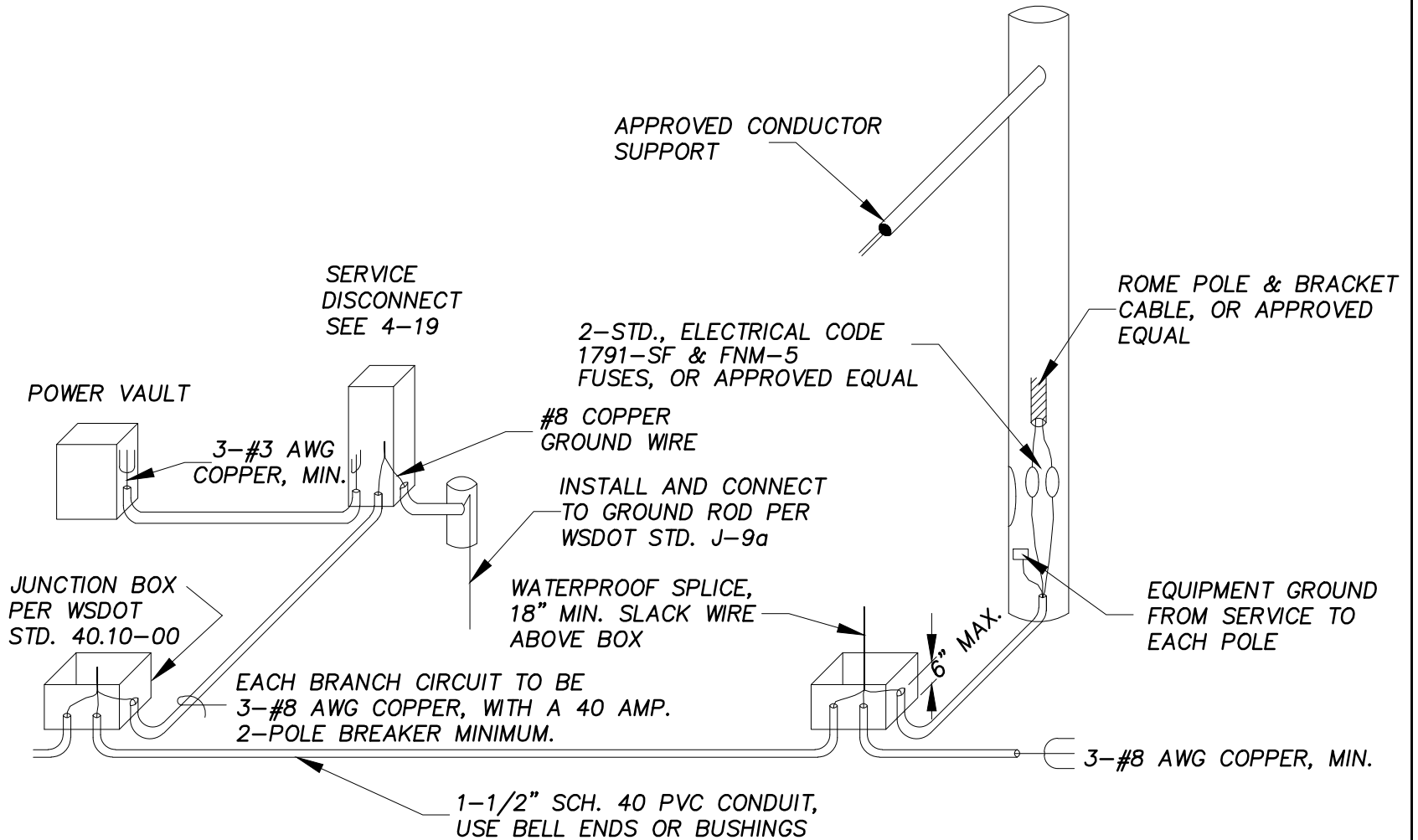

APPROVED BY	REVISED DATE	CITY OF OLYMPIA TYPICAL STREET LIGHT INSTALLATION	STD. PLAN NO.
CITY ENGINEER	1/24/2011		4-31

NOTES:

- ① ALL REINFORCING STEEL SHALL HAVE 2-1/2" CLEAR COVER OF CONCRETE.
- ② PROVIDE WATER TIGHT GROUT JOINT BETWEEN BASE OF POLE AND CONCRETE.
- ③ PROVIDE 3/8" EXPANSION JOINT WHEN PLACED IN A SIDEWALK AREA. (TYP)
- ④ 1-1/2" MINIMUM CONDUIT. TYPE AND SIZE CONDUIT BETWEEN BASES AS SHOWN ON THE PLANS. USE OF NON-METALLIC CONDUIT IS PERMISSABLE. CONDUIT SHALL BE PLACED WITHIN THE BACK OR FRONT 12" OF NEW OR PROPOSED SIDEWALK LINE UNLESS OTHERWISE APPROVED.
- ⑤ ANCHOR BOLTS AND BOLT CIRCLE TO MEET MANUFACTURE SPECIFICATIONS. SET BOLT HEIGHT TO PERMIT DOUBLE LOCKNUT FOR ADJUSTMENT.

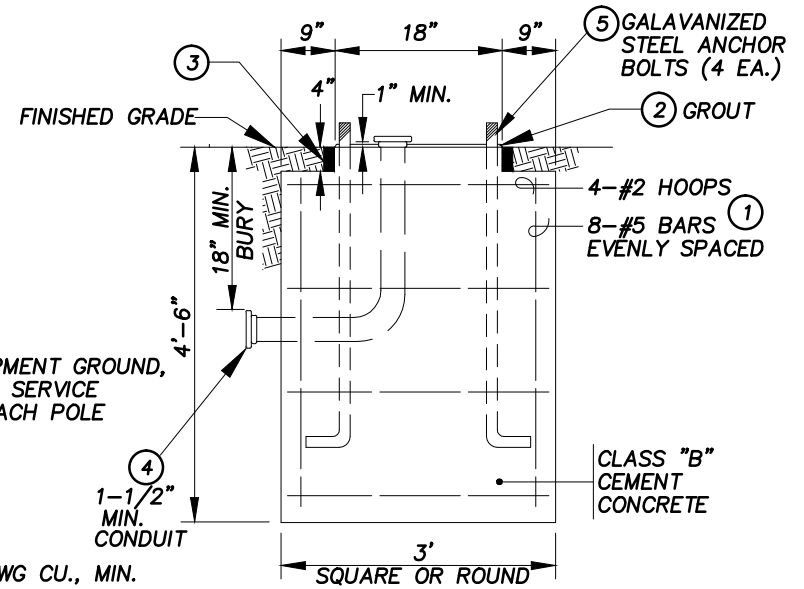
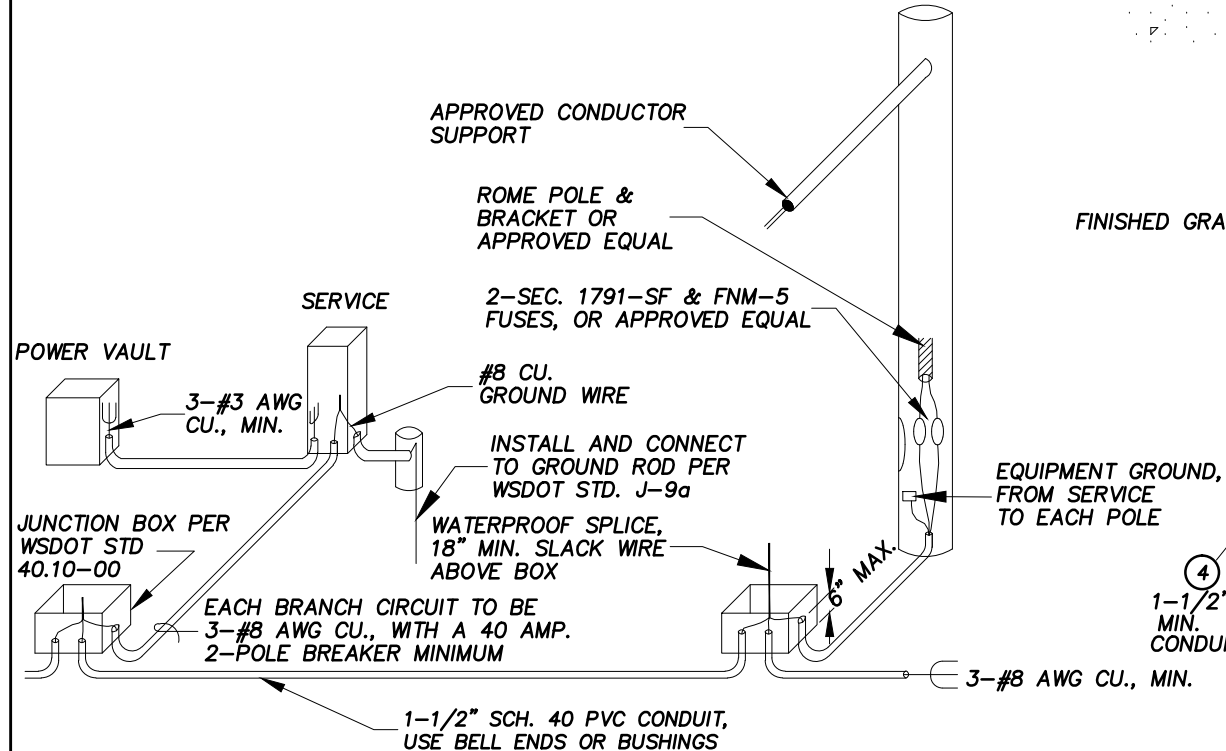
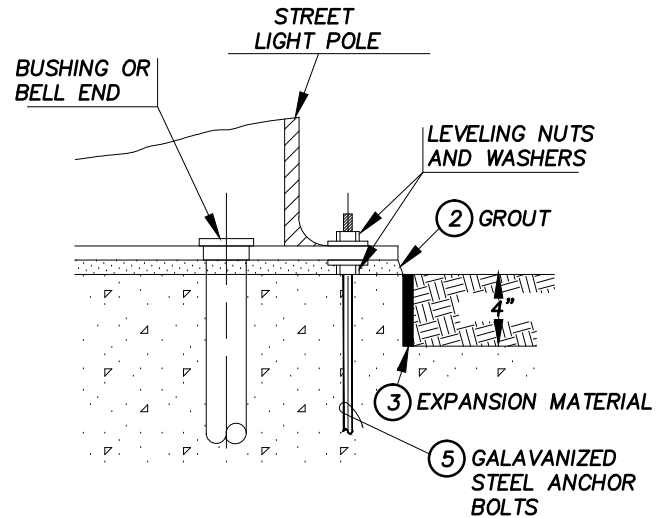

TYPICAL BASE DETAIL

TYPICAL STREET LIGHT INSTALLATION

APPROVED BY	REVISED DATE
CITY ENGINEER	1/24/2011

CITY OF OLYMPIA
STREET LIGHT INSTALLATION
DETAILS COMBINED

STD. PLAN NO.
4-31A

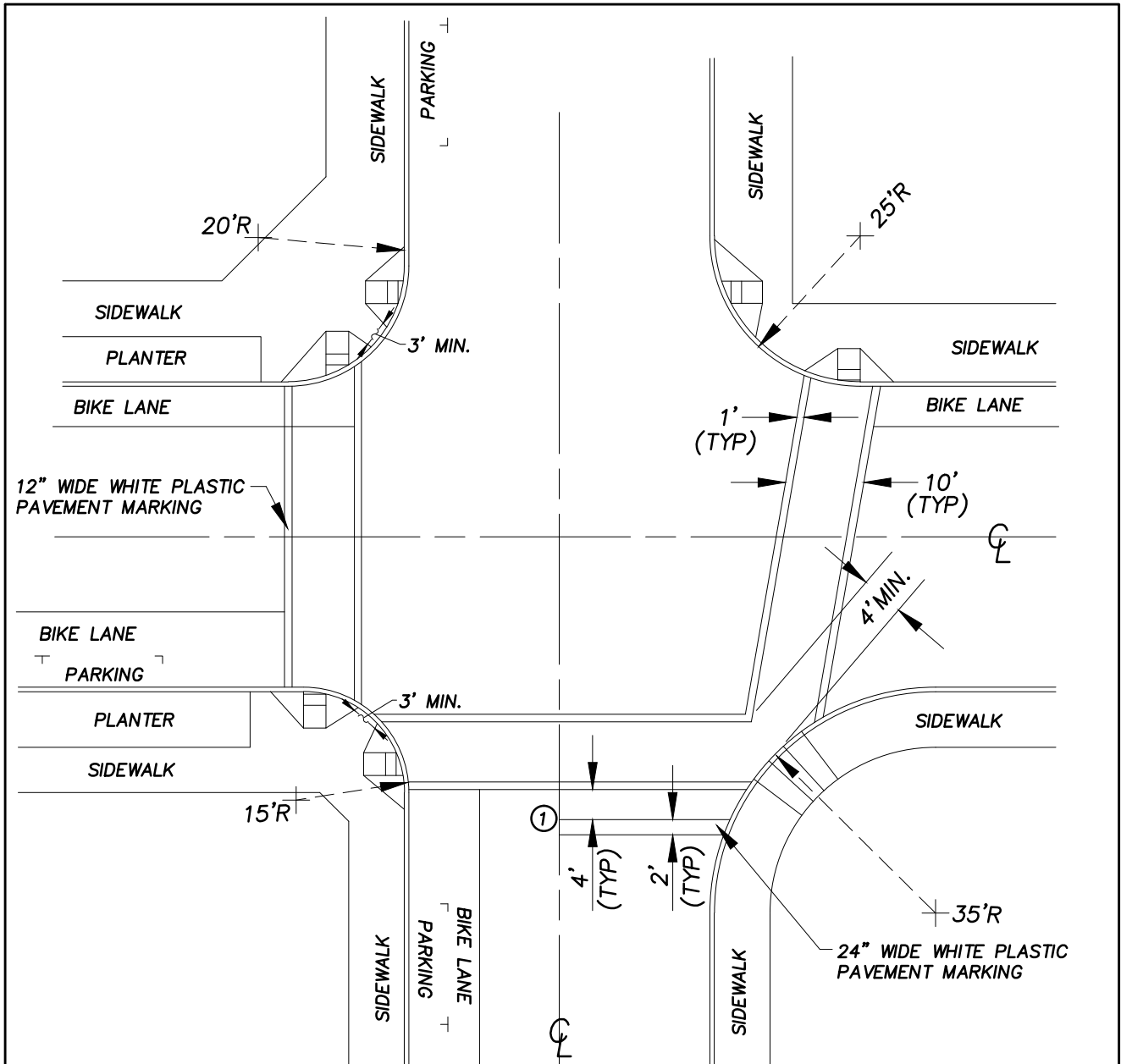

NOTES:

1. INSTALL STOP BAR ONLY IF SHOWN ON STRIPING PLANS OR IF DIRECTED BY THE ENGINEER.
2. IT IS THE INTENT OF THE ENGINEERING DESIGN AND DEVELOPMENT STANDARDS TO HAVE CONSTRUCTED ACCESS RAMPS THAT MINIMIZE PEDESTRIAN CROSSING DISTANCES, AND POSITION PEDESTRIANS WHERE THEY CAN BEST BE SEEN BY ONCOMING TRAFFIC. CURB RAMP ORIENTATION WILL ALIGN PEDESTRIANS PARALLEL WITHIN THE LATERAL EXTENSION LINES OF THE SIDEWALK. INTERSECTION RADIUS LESS THAN 35' WILL USE TWO PERPENDICULAR CURB ACCESS RAMPS PER CORNER. WHERE INTERSECTION CORNERS ARE OFF-SET, CURB ACCESS RAMPS WILL ORIENT DIAGONALLY TO THE OPPOSING CURB ACCESS RAMP. DISTANCE BETWEEN ACCESS RAMPS WILL NOT BE LESS THAN 3' WITH A SLOPE NO GREATER THAN 7.5%. CENTER AND DIRECTION OF RAMP SHALL BE LOCATED WITHIN CROSSWALK LINES AS CLOSE AND PARALLEL AS TO CROSSWALK CENTERLINE AS POSSIBLE.
3. ROADWAY WIDTHS MAY VARY IN RETROFIT SITUATIONS. STANDARD LANE WIDTH IS 10 FEET.

APPROVED BY	REVISED DATE	CITY OF OLYMPIA	STD. PLAN NO.
	4/11/2012	CROSSWALK AND CURB RAMP LOCATIONS / STOP BAR DIMENSIONS FOR RETROFIT SITUATIONS	4-32
CITY ENGINEER			

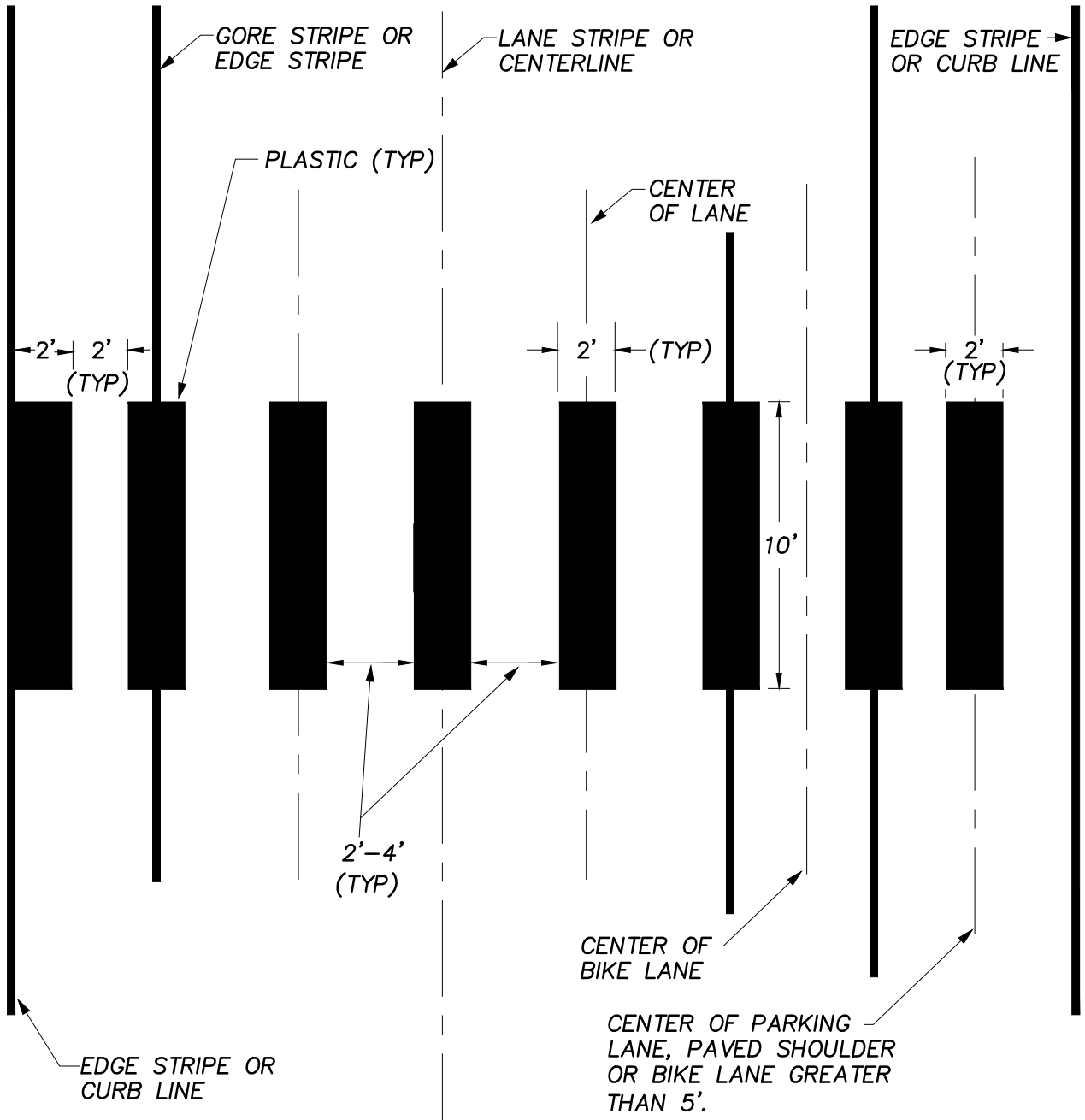

NOTE: THE MARKING DESIGN SHOULD AVOID THE WHEEL PATHS, AND THE SPACING SHOULD NOT EXCEED 4 FEET.

APPROVED BY	REVISED DATE	CITY OF OLYMPIA	STD. PLAN NO.
	9/20/2012	BAR-TYPE	4-32A
CITY ENGINEER		CROSSWALK DETAIL	

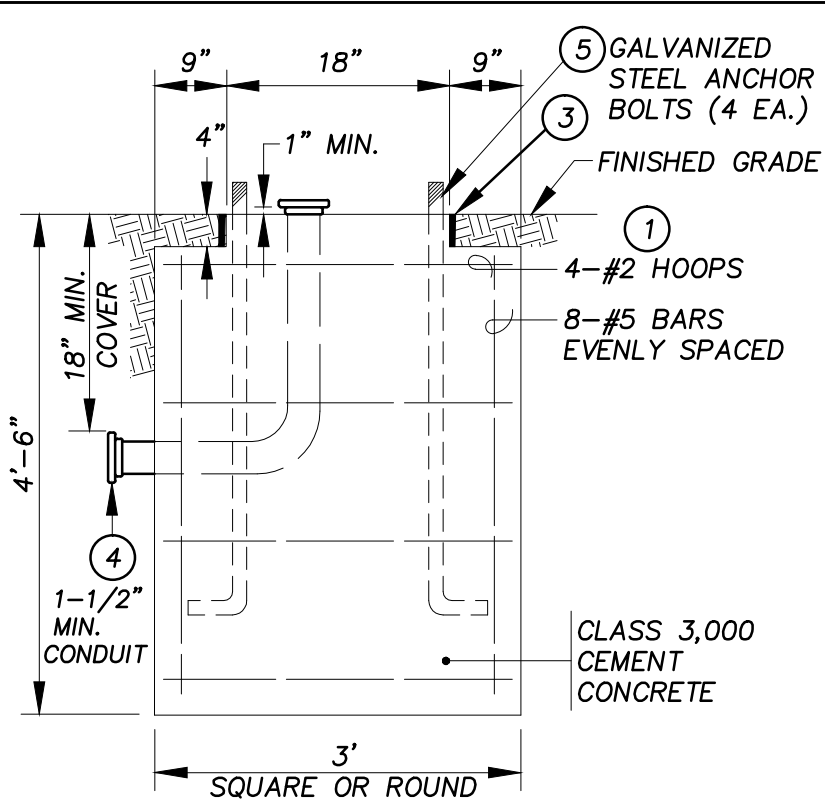

NOTES:

- ① ALL REINFORCING STEEL SHALL HAVE 2-1/2" CLEAR COVER OF CONCRETE.
- ② PROVIDE WATER TIGHT GROUT JOINT BETWEEN BASE OF POLE AND CONCRETE.
- ③ PROVIDE 3/8" EXPANSION JOINT WHEN PLACED IN A SIDEWALK AREA. (TYP)
- ④ 1-1/2" MINIMUM CONDUIT. TYPE AND SIZE CONDUIT BETWEEN BASES AS SHOWN ON THE PLANS. USE OF NON-METALLIC CONDUIT IS PERMISSIBLE. CONDUIT SHALL BE PLACED WITHIN THE BACK 12" OF NEW OR PROPOSED SIDEWALK LINE UNLESS OTHERWISE APPROVED.
- ⑤ ANCHOR BOLTS AND BOLT CIRCLE TO MEET MANUFACTURE SPECIFICATIONS. SET BOLT HEIGHT TO PERMIT DOUBLE LOCKNUT FOR ADJUSTMENT.
- ⑥ CHECK SHOP DRAWINGS TO ENSURE SHROUD COVERS ANCHOR BOLT PAD AND MAKE SURE ANCHOR BOLTS HAVE ENOUGH COVERAGE.

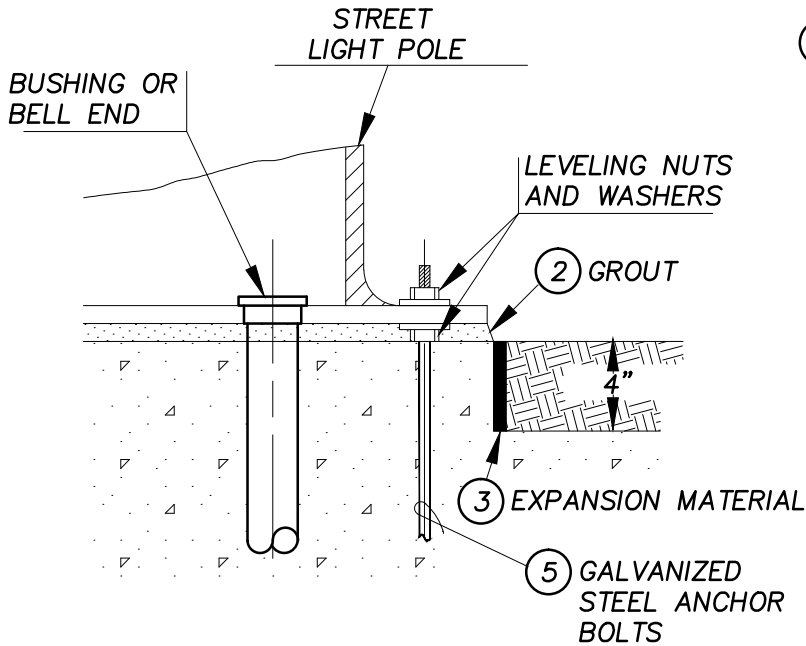

APPROVED BY	REVISED DATE	CITY OF OLYMPIA	STD. PLAN NO.
	7/26/06	STREETLIGHT STANDARD	4-33
CITY ENGINEER		FOUNDATION	

LUMINAIRE FOUNDATION

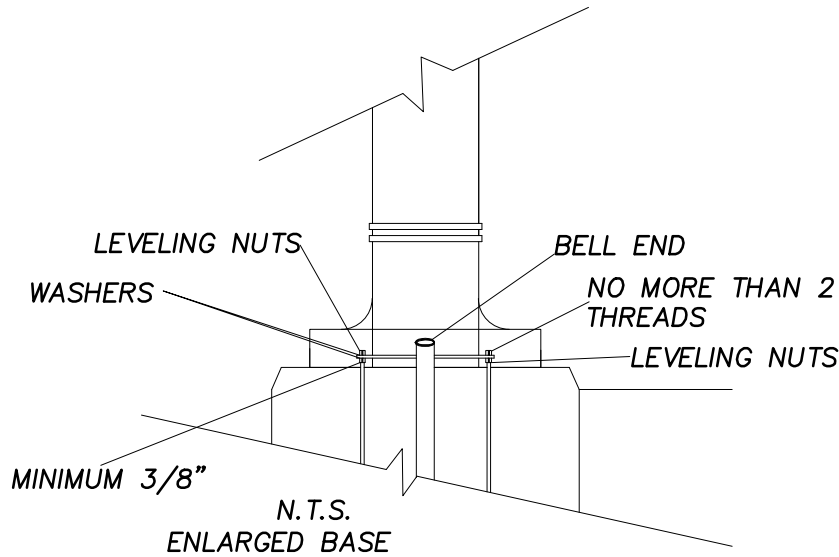

GENERAL NOTES:

- 1) THE FOUNDATION IS DESIGNED FOR 2000 PSP AVERAGE SOIL LATERAL BEARING PRESSURE.
- 2) BOLT PATTERN PER MANUFACTURES SPECIFICATIONS.
- 3) FOR DETAILS NOT SHOWN USE MANUFACTURES SPECIFICATIONS AND DETAILS.
- 4) THE MINIMUM DISTANCE FROM FACE OF CURB TO THE FACE OF LUMINAIRE IS 2 FEET- 6 INCES.
- 5) INSTALL EXPANSION JOINTS ON THREE SIDES OF J-BOX.
- 6) FOUNDATION HOLES SHALL BE AUGURED. IF HOLES ARE DUG, BACKFILL SHALL MEET WSDOT/APWA SECTION 8-20.3 AND 2-09.3 (1) E.

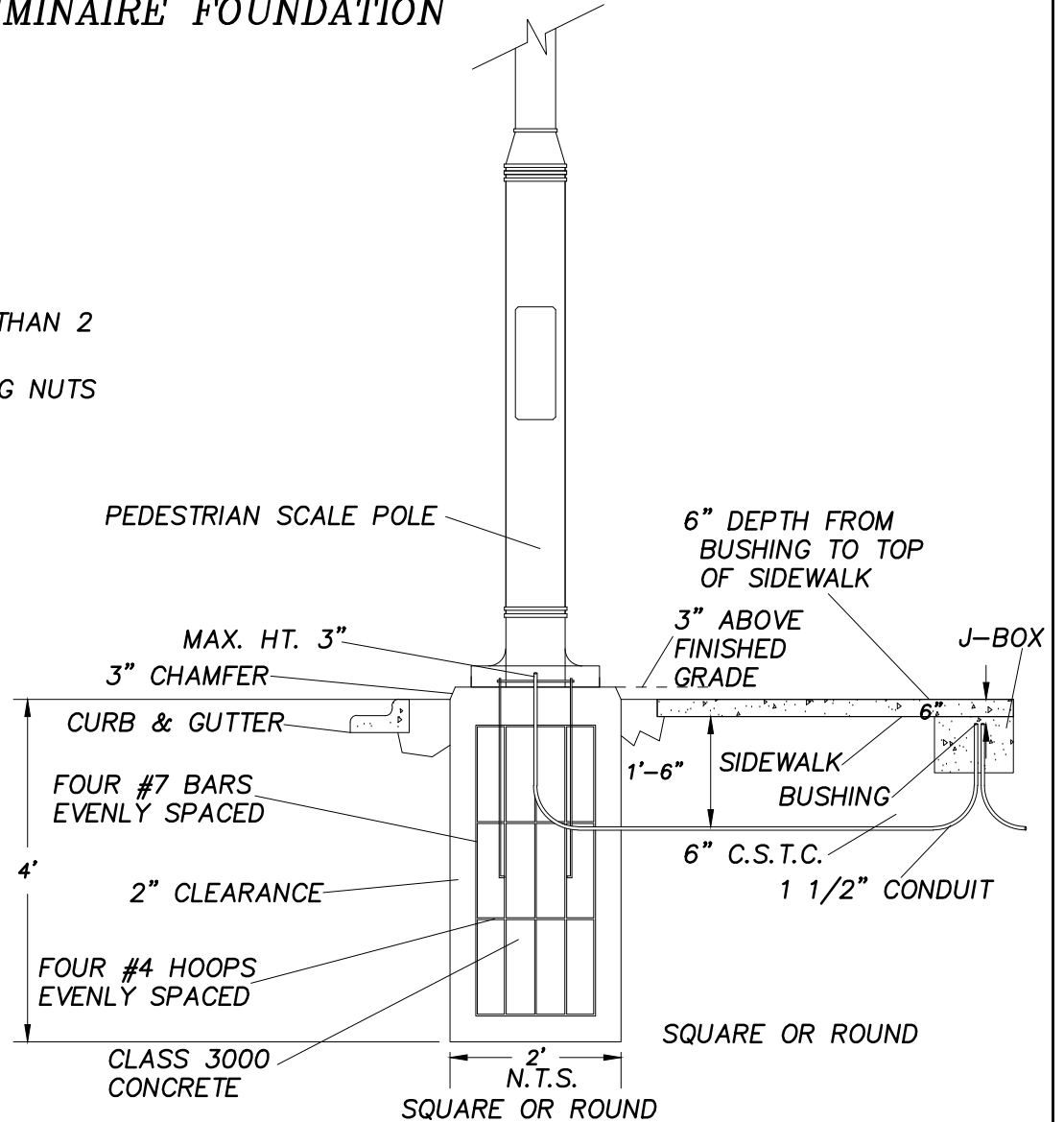

APPROVED BY	REVISED DATE	CITY OF OLYMPIA	STD. PLAN NO.
	1/24/2011	LUMINAIRE FOUNDATION FOR PEDESTRIAN SCALE POLES	4-33A
CITY ENGINEER			

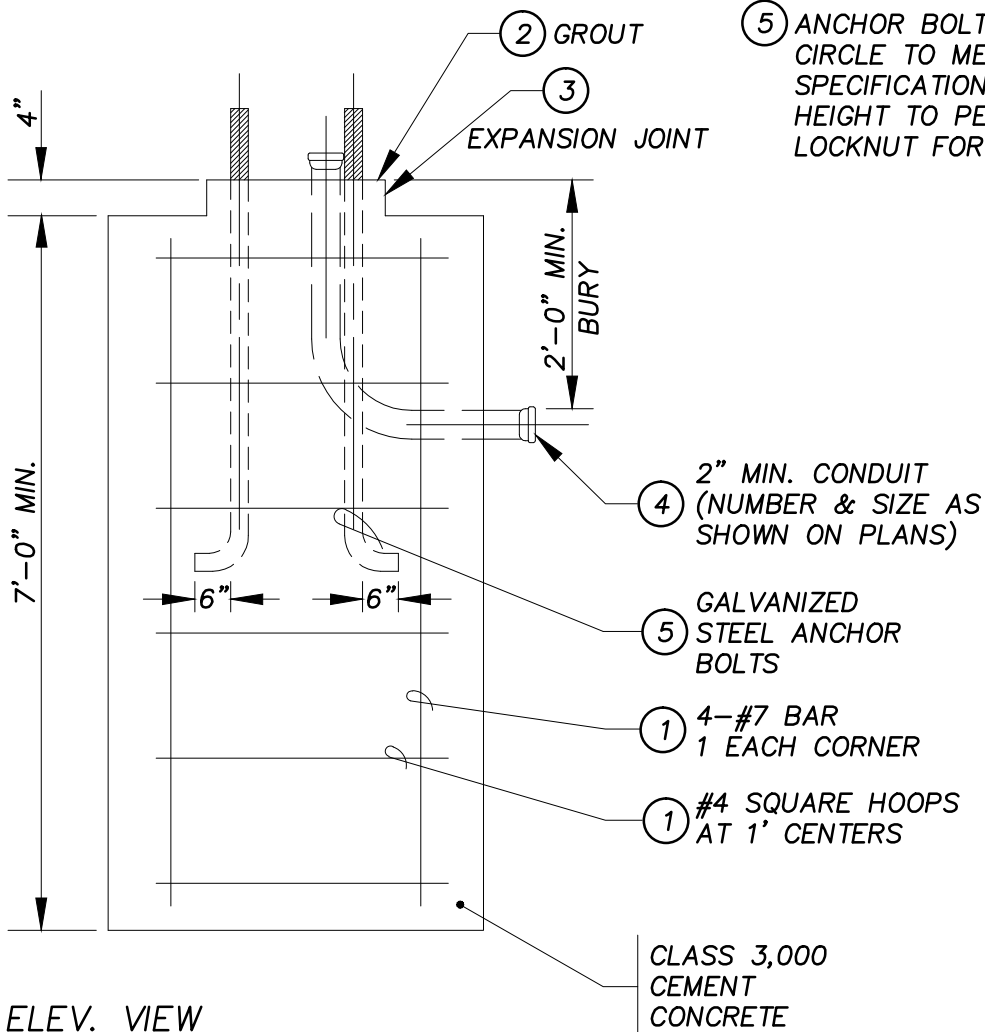
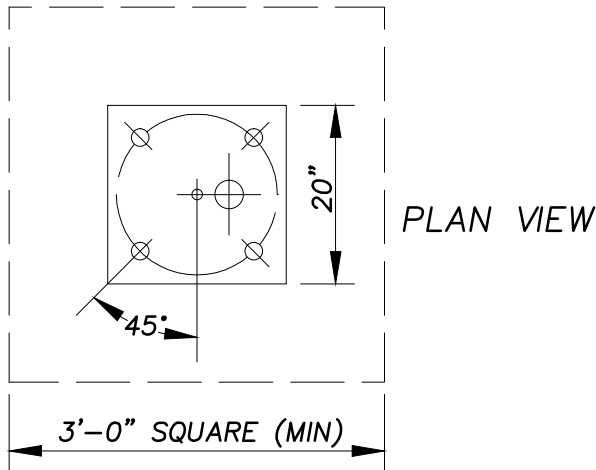

NOTES:

- ① ALL REINFORCING STEEL SHALL HAVE 2-1/2" CLEAR COVER OF CONCRETE.
- ② PROVIDE WATER TIGHT GROUT JOINT BETWEEN BASE OF POLE AND CONCRETE.
- ③ PROVIDE 3/8" EXPANSION JOINT WHEN PLACED IN SIDEWALK AREA.
- ④ 2" MINIMUM CONDUIT SIZE. BUSHING OR BELL ENDS REQUIRED ON CONDUIT. USE OF NON-METALLIC CONDUIT IS PERMISSABLE.
- ⑤ ANCHOR BOLTS AND BOLT CIRCLE TO MEET MANUFACTURE SPECIFICATIONS. SET BOLT HEIGHT TO PERMIT DOUBLE LOCKNUT FOR ADJUSTMENT.

APPROVED BY	REVISED DATE	CITY OF OLYMPIA	STD. PLAN NO.
	11/1/04	SIGNAL OR STRAIN POLE FOUNDATION	4-34
CITY ENGINEER			

DIRECTION OF TRAVEL

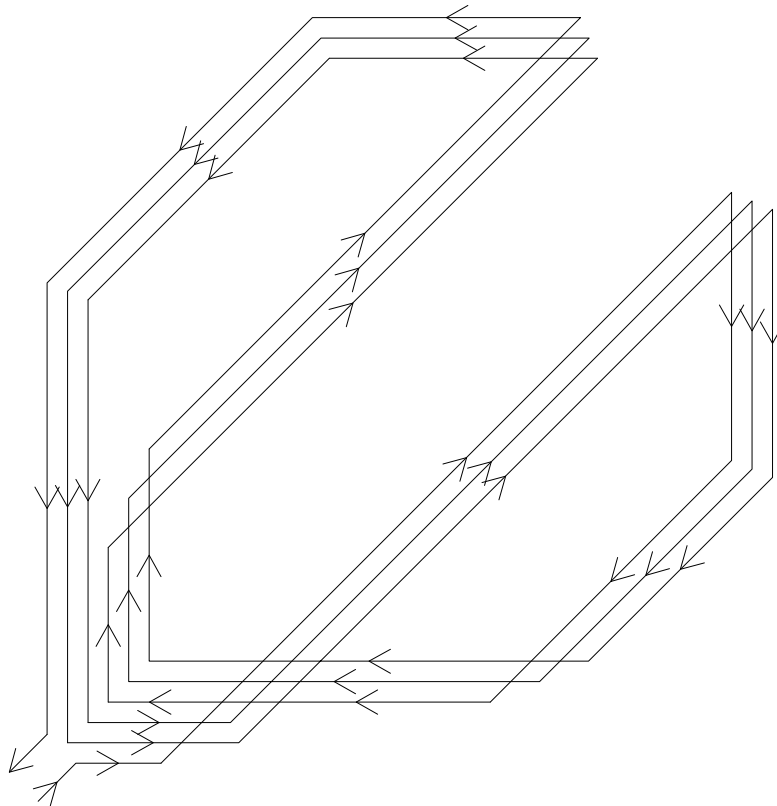

WINDING DETAIL

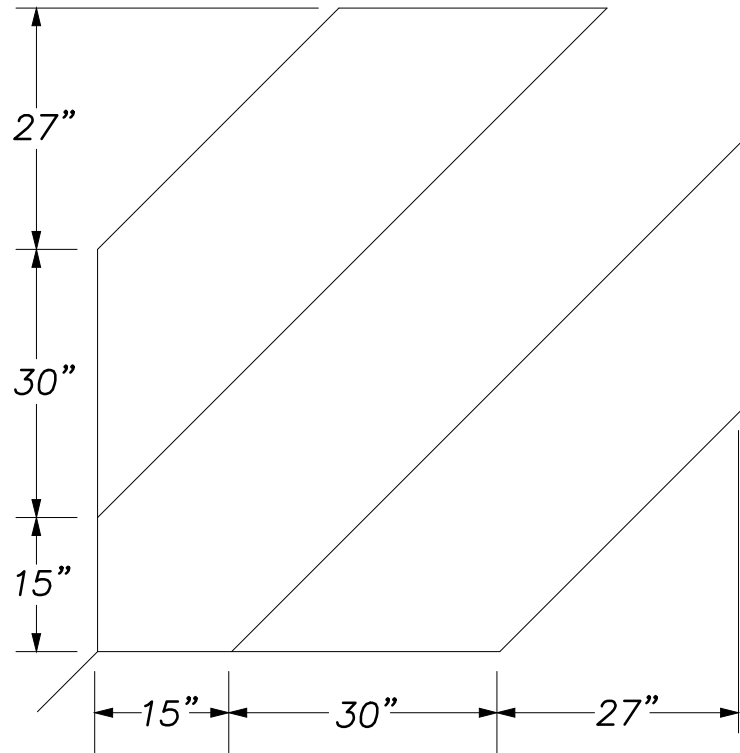

SAWCUT DETAIL

APPROVED BY	REVISED DATE	CITY OF OLYMPIA	STD. PLAN NO.
	11/1/04	TYPE "D" LOOP FOR BICYCLE LANES	4-35
CITY ENGINEER			

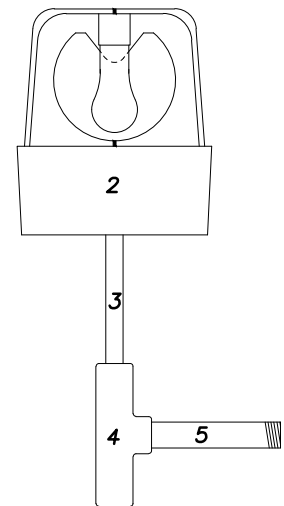
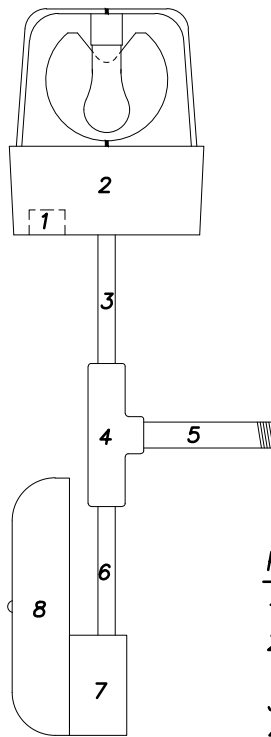

PARTS LIST:

- 1 - FLASHER, TRAFFIC SENSOR CORP., P\N 25 DF
- 2 - BEACON, TRIPPLITE, MARK VI 120VAC WITH CLEAR LENS
- 3 - NIPPLE, 1/2"X 6"
- 4 - CONDUIT BODY, T 1/2"X 1/2"X 3/4" OR LB 1/2" x 3/4"
- 5 - NIPPLE, 3/4"X 4"
- 6 - NIPPLE, 1/2"X 6"
- 7 - BELL, FEDERAL SIGNAL CORP., 700-120-1 HOUSED IN A FEDERAL SIGNAL CORP. GRAY WEATHER PROOF BOX, MODEL WB
- 8 - GONG, FEDERAL SIGNAL CORP., MODEL A10

**BEACON / GONG
WIRING SCHEMATIC**

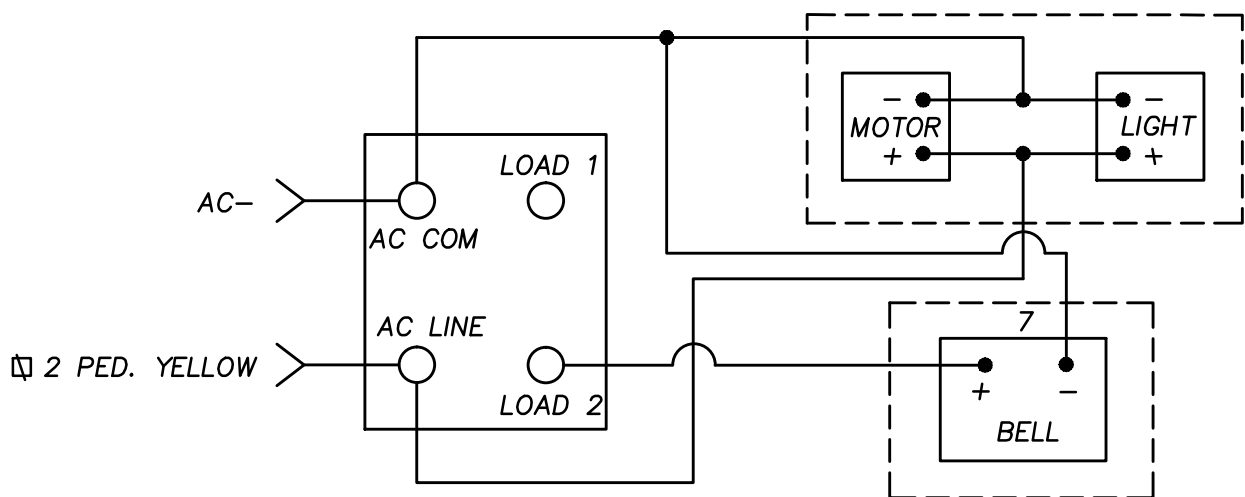

APPROVED BY	REVISED DATE	CITY OF OLYMPIA	STD. PLAN NO.
	1/27/94	BEACON/GONG ASSEMBLY FOR EMERGENCY VEHICLE PREEMPTION INDICATION	4-36
CITY ENGINEER			

DIMENSION – INCHES										
A	B	C	D	E	F	G	H	I	J	K
18	5.33 MINIMUM	1.875	8D UPPER CASE	0.75	6D LOWER CASE	6	4D UPPER CASE	Z	4	5

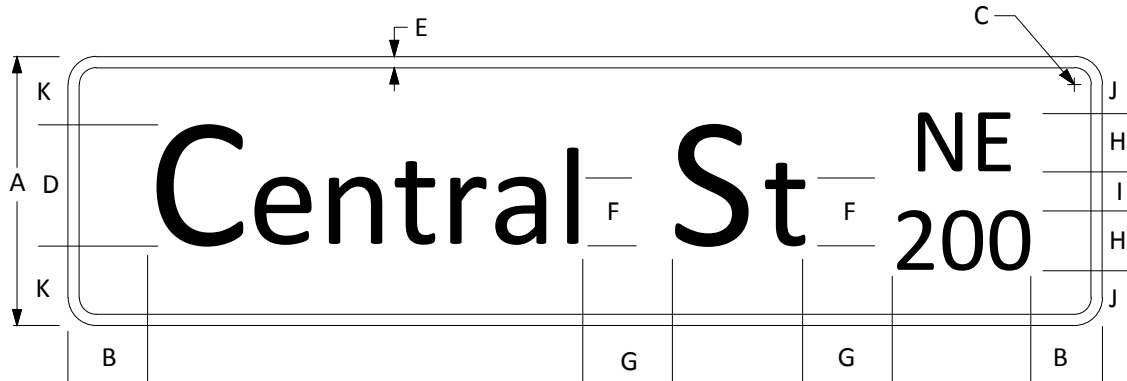
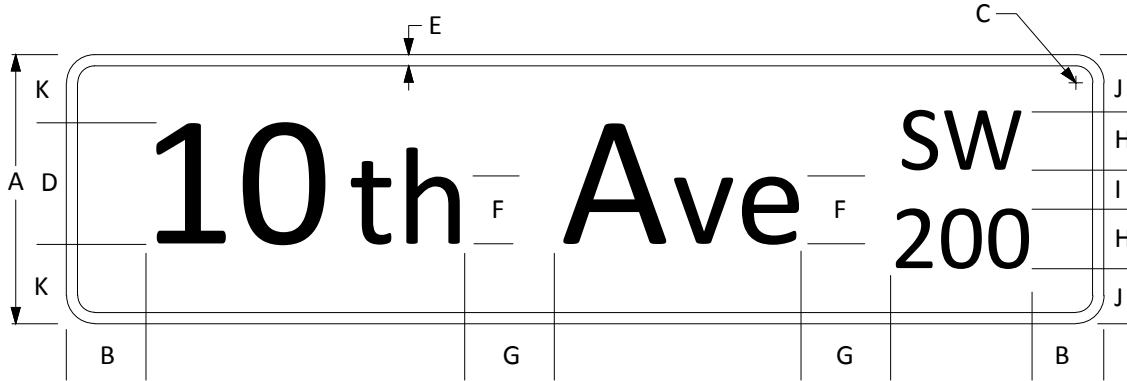

NOTES:

1. TYPE III OR IV REFLECTIVE SHEETING SHALL BE USED FOR BACKGROUND, LETTERS, NUMERALS AND BORDERS.
2. SIGN BLANK SHALL BE 0.080 INCH SHEET ALUMINUM.
3. SIGN LAYOUT SHALL BE ACCORDING TO DETAIL SHOWN ABOVE.
4. DIMENSIONING SHALL BE IN ACCORDANCE WITH THE "WASHINGTON STATE SIGN FABRICATION MANUAL".
5. WITH APPROVAL OF THE ENGINEER, C SERIES LETTERS AND NUMERALS CAN BE SUBSTITUTED FOR THE D SERIES LETTERS AND NUMERALS IF THE MAXIMUM SIGN LENGTH OF SEVEN FEET IS EXCEEDED USING D SERIES LETTERS.

APPROVED BY	REVISED DATE	CITY OF OLYMPIA	STD. PLAN NO.
	4/10/2012	MAST ARM	4-37
CITY ENGINEER		STREET SIGN CONSTRUCTION	

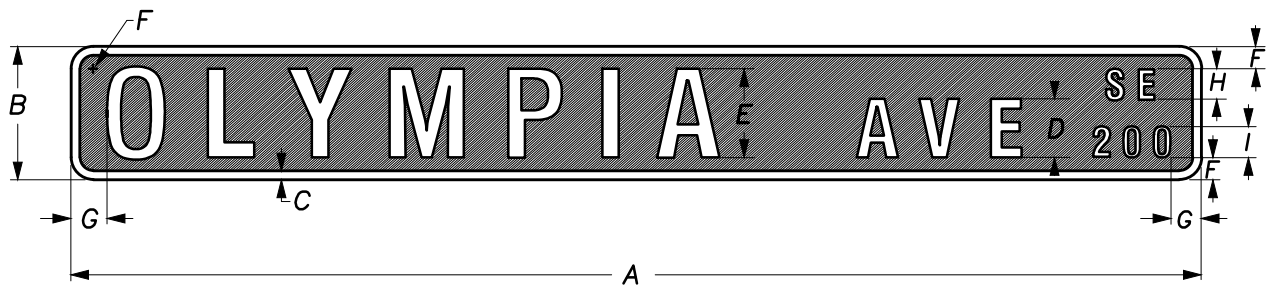

DIMENSIONS (INCHES)

A	B	C	D	E	F	G	H	I	J
48 MAX.	9	5/8	4	6	1 1/2	2	2	2	1 1/2

SIGN BLANK SHALL BE:

- 0.080" sheet aluminum

LETTERING SHALL BE:

- 6" Highway B Series for street name
- 4" Highway C Series for AVE, ST, or RD designation
- 2" Highway C Series for quadrant (NE, SE, etc)
- 2" Highway C Series for block number

Letter spacing per WSDOT Sign Fabrication Manual

SHEETING SHALL BE:

- Type III or IV Micro Prismatic Retroreflective material for background, letters, numerals and borders

COLORS:

- Legend – White (reflective)
- Background – Green (reflective)
- Border – White (reflective)

APPROVED BY	REVISED DATE	CITY OF OLYMPIA	STD. PLAN NO.
	1/23/09	STREET NAME SIGN	4-37A
CITY ENGINEER			

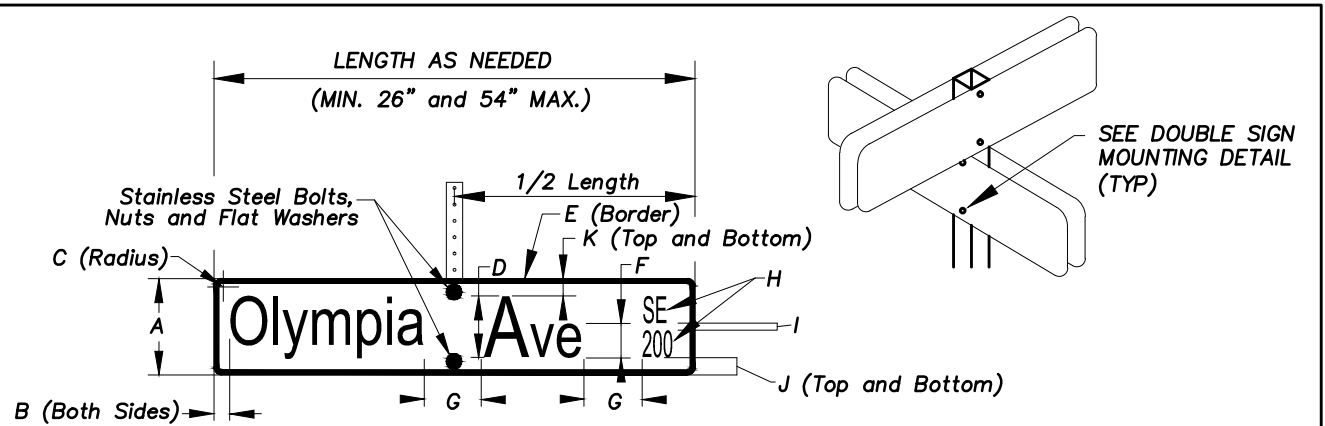

DIMENSION (INCHES)												
	A	B	C	D	E	F	G	H	I	J	K	Notes
Post Mounted	12	4.5	1.5	6	0.50	4.0	4.5	3	2	2	3	Typical Sign Detail

Road Designation Abbreviations

Street	St	Court	Ct
Avenue	Ave	Drive	Dr
Place	Pl	Road	Rd
Way	Way	Circle	Cir
Boulevard	Blvd	Trail	Tr
Parkway	Pwky	Highway	Hwy
Lane	Ln	Loops	Lp

Area Abbreviations

East	E	Northwest	NW
West	W	Northeast	NE
North	N	Southwest	SW
South	S	Southeast	SE

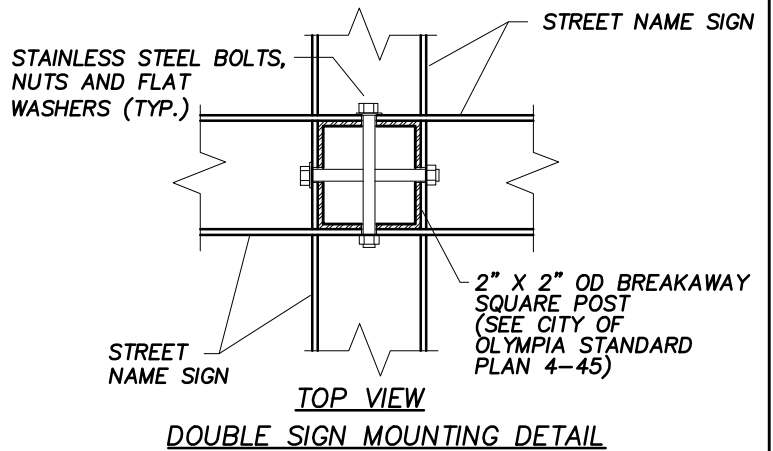

NOTES:

Lettering Requirements;

- Standard Letter Series "C" and letter spacing as per Washington State Department of Transportation Sign fabrication Manual shall be used.
- Lettering shall be a combination of upper and lower case letters per the 2009 Federal Highway Administration (FHWA) Manual on Uniform Traffic Control Devices (MUTCD). Street name will be all lower case with the first letter upper case. If the street is numbered then the suffix of the street number shall be lower case and shall be $\frac{3}{4}$ height of the numbered capital letters.
- Use standard roadway designations and area abbreviations as indicated.

Sign Manual Requirements;

- Color;
 - Background – Green (reflective sheeting)
 - Legend – White (reflective sheeting)
 - Border – White (reflective sheeting)
- Sign blanks shall be 0.080" sheet aluminum.
- Reflective sheeting shall be Type III or IV Microprismatic material for background, letters, numerals and borders.

General Notations;

- All street name signs shall be single sided with double sign mounting. See double sign mounting detail for ground mounted signs.
- Engineer shall approve face copy prior to fabrication.

APPROVED BY	REVISED DATE	CITY OF OLYMPIA	STD. PLAN NO.
	4/13/2011	STREET NAME SIGN	4-37B
CITY ENGINEER			

SPACING (TYPICAL)

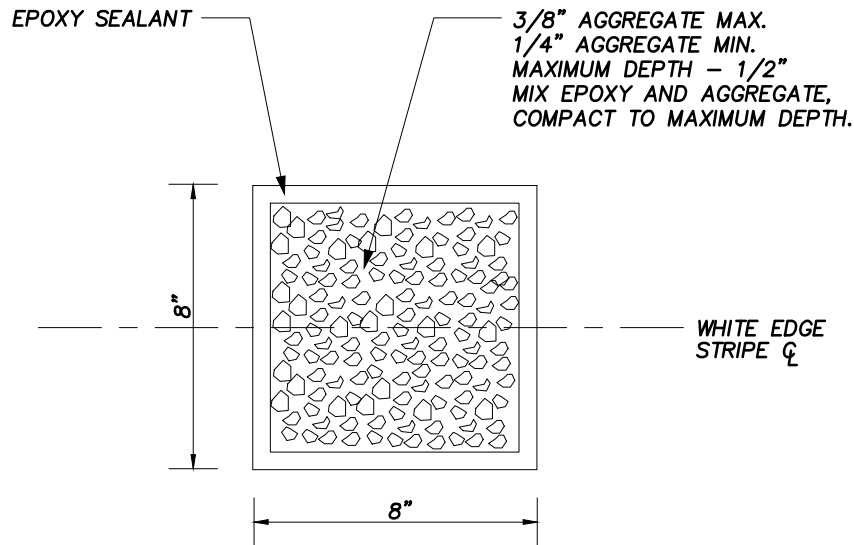
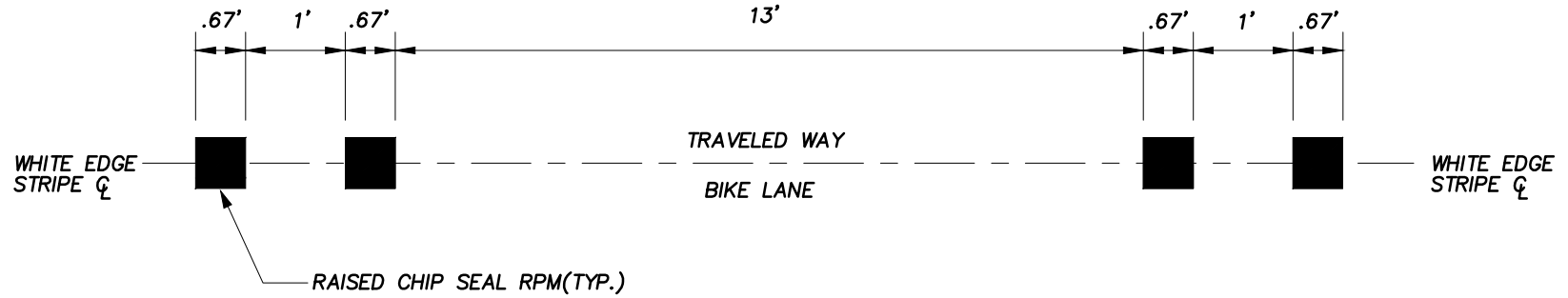

NOTE:

- PAINT 8" WHITE EDGE STRIPE OVER RAISED CHIP SEAL PAVEMENT MARKING.
- MATERIAL USED FOR CHIP SEAL RUMBLE STRIP ADHESIVE SHALL BE "SUPER BUNDT" AS MANUFACTURED BY FLINT TRADING, INC. P.O. BOX 160, THOMASVILLE, NC, 27361-0160 OR APPROVED EQUAL. PAVEMENT MUST BE CLEAN AND DRY. THE 3/8" PEA GRAVEL SHALL BE CLEAN AND DRY. DIMENSION FOR THE CHIP SEAL RUMBLE STRIP IS EIGHT (8) INCHES SQUARE AND SHALL BE PLACED AS SHOWN ON THE PLANS OR AS DIRECTED BY ENGINEER.
- PAVEMENT MARKINGS SHALL BE INSTALLED AS PER MANUFACTURERS RECOMENDATIONS.

APPROVED BY	REVISED DATE	CITY OF OLYMPIA	STD. PLAN NO.
	5/31/2011	CHIP SEAL RUMBLE STRIP MARKING DETAIL	4-38
CITY ENGINEER			

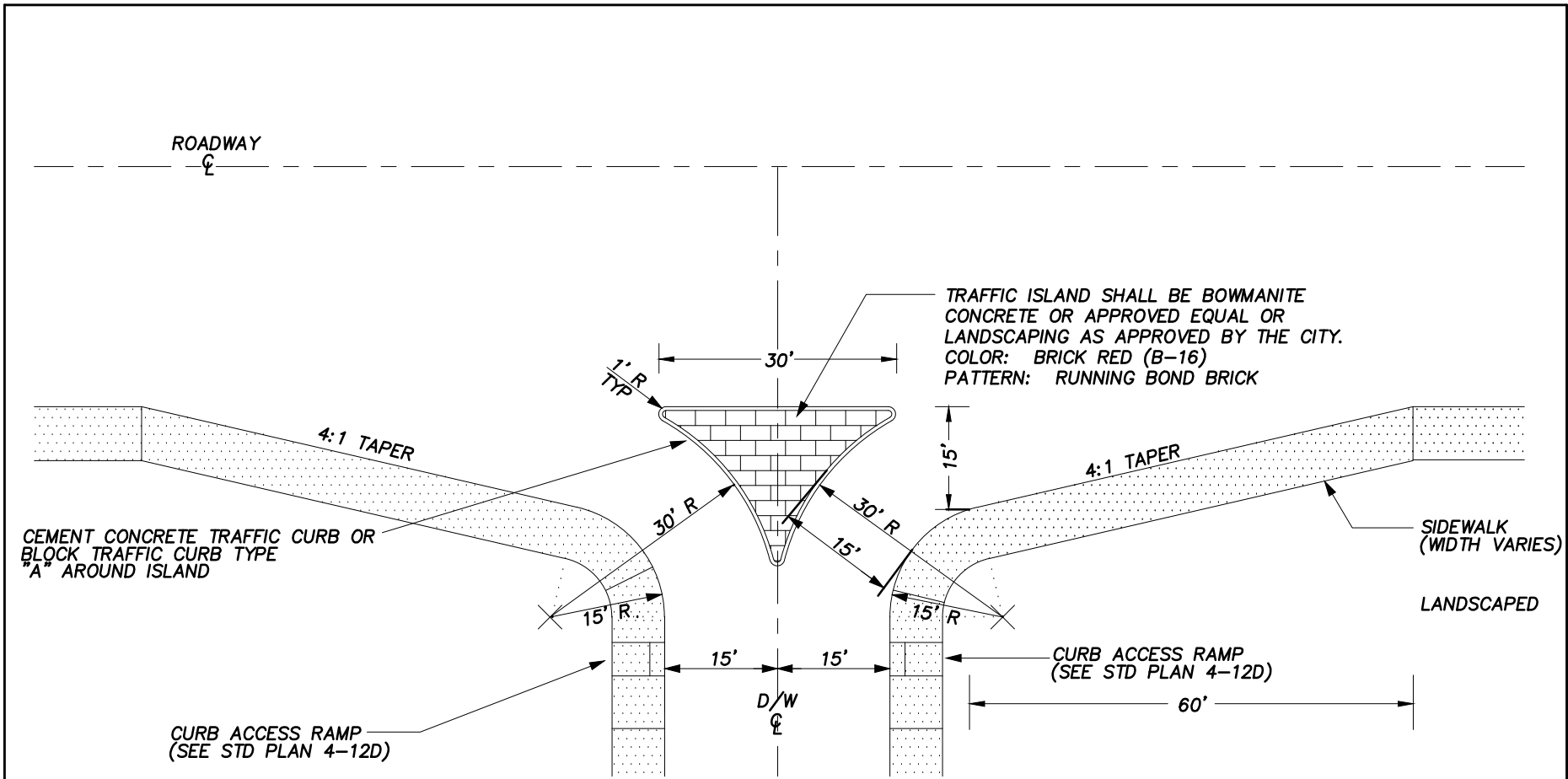

NOTE:

- CEMENT CONCRETE TRAFFIC CURB SHALL BE USED WHEN TRAFFIC ISLAND IS LANDSCAPED

APPROVED BY	REVISED DATE	CITY OF OLYMPIA	STD. PLAN NO.
	1/24/2011	RIGHT - IN, RIGHT - OUT DETAIL	4-39
CITY ENGINEER			

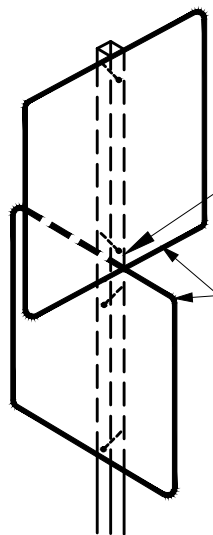

TRAFFIC CIRCLE SIGN MOUNTING DETAIL

SEE STANDARD PLAN 4-45 FOR TYPICAL SIGNS INSTALLATION DETAIL.
SIGN PLACEMENT (TYP.)

INSTALL TYPE 2 RPM (YY) AT 24" O.C., WITH ALTERNATING ORIENTATION. (TYP.)

ALL LANDSCAPING AND STRUCTURES CONSTRUCTED IN THE ISLAND SHALL BE SUBMITTED FOR APPROVAL TO THE CITY PRIOR TO CONSTRUCTION.

CEMENT CONC. MOUNTABLE CURB

EXPANSION JOINT (TYP) SEE NOTE 1 THIS PAGE

INSTALL SIGN POST AND BASE 1' INSIDE CURB, WITH BASE INSTALLED PER STANDARD PLAN 4-45, EDGE OF ROAD (NO SIDEWALK) DETAIL. (TYP) 5' MINIMUM MOUNTING HEIGHT TO BOTTOM OF LOWEST SIGN ON POST. (TYP)

SIGN FACE

12" - #3 EPOXY COATED BARS (TYP. ALL JOINTS)

SIGN FACE

INSTALL TRAFFIC CIRCLE SIGNS PER STANDARD PLANS 4-40D TO 4-40H, OR AS DIRECTED BY THE ENGINEER. SEE TRAFFIC CIRCLE SIGN MOUNTING DETAIL (TYP.)

PLAN VIEW
NO SCALE

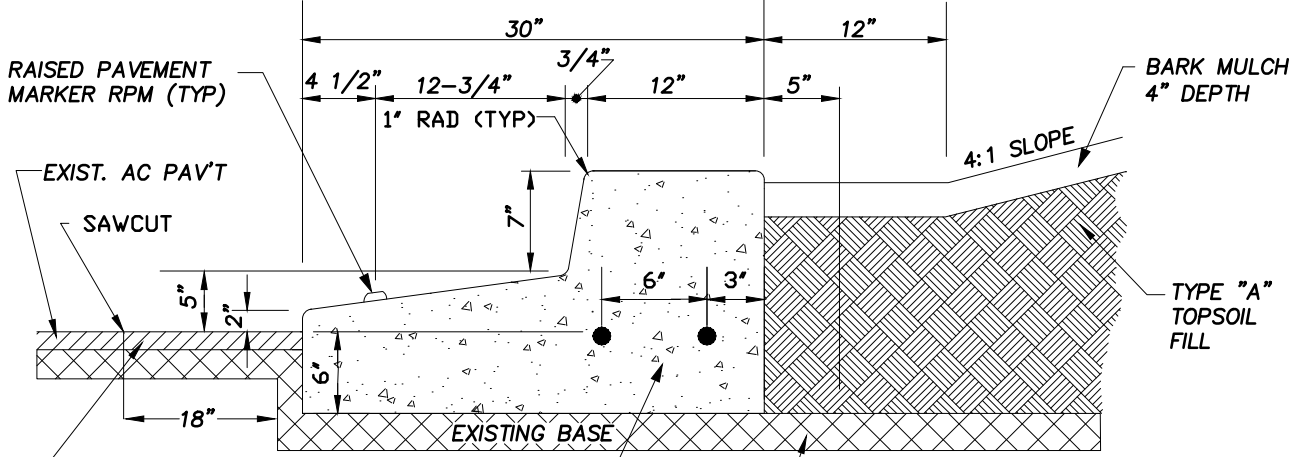

RAISED PAVEMENT MARKER RPM (TYP)

BARK MULCH 4" DEPTH

EXIST. AC PAV'T

4:1 SLOPE

SAWCUT

TYPE "A" TOPSOIL FILL

REMOVE EXIST. PAV'T. TO SAW CUT LINE. SEE STD. PLAN 4-8C FOR ASPHALT PAVEMENT RESTORATION DETAILS.

CEMENT CONC. MOUNTABLE CURB

EXISTING SUBGRADE MATERIAL

SECTION A-A

NO SCALE

NOTE:

1. EXPANSION JOINT MATERIAL SHALL BE 3/8" THICK PREMOLDED JOINT FILLER FULL THICKNESS OF CONCRETE.

APPROVED BY	REVISED DATE	CITY OF OLYMPIA	STD. PLAN NO.
	11/14/2011	TRAFFIC CIRCLE	4-40A
CITY ENGINEER			

LEGEND:

- A Street Width
- B Curb Return Radius
- C Off-Set Distance
- D Circle Diameter
- E Opening Width

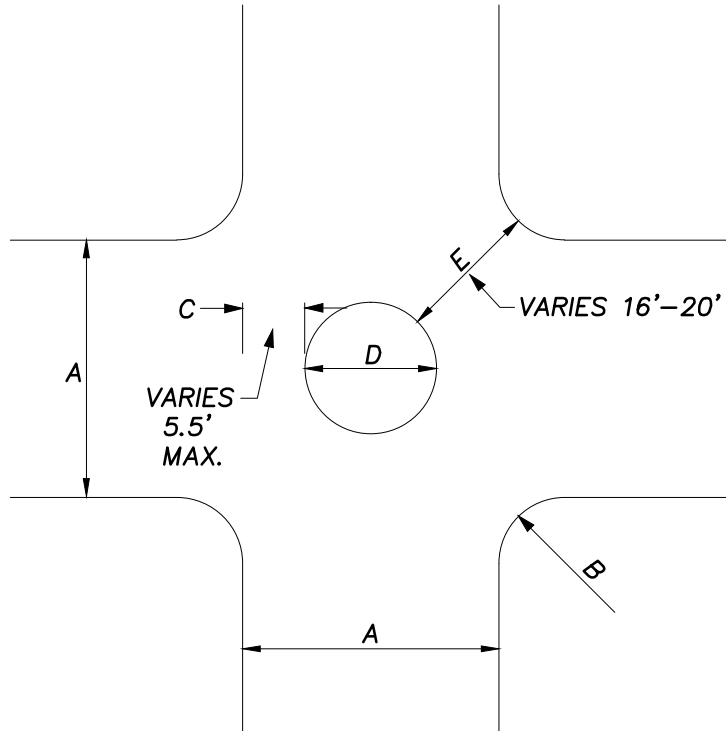

INTERSECTION DIAGRAM

OPTIMUM CRITERIA

<u>IF C =</u>	<u>THEN</u>	<u>E WILL BE</u>
5.5' MAX		16' MIN
5.0'		17' +
4.5'		18' +
4.0'		19' +
3.5' OR LESS		20'

APPROVED BY	REVISED DATE	CITY OF OLYMPIA	STD. PLAN NO.
	2/26/08	TRAFFIC CIRCLE	4-40B
CITY ENGINEER		INTERSECTION DIAGRAM	

A STREET WIDTH	B CURB RETURN RADIUS	C OFF-SET DISTANCE	D CIRCLE DIAMETER	E OPENING WIDTH
20' ↓	<15' 15' 18' 20' 25'	RECONSTRUCT CURBS 5.5' 5.0' 4.5' 4.0'	9' 10' 11' 12'	16'+ 17'+ 18'- 19'+
24' ↓	<12' 12' 15' 20' 25'	RECONSTRUCT CURBS 5.5' 5.0' 4.5' 3.5'	13' 14' 15' 17'	16' 17'- 18'+ 20'-
25' ↓	<12' 12' 15' 18' 20' 25'	RECONSTRUCT CURBS 5.5' 5.0' 4.5' 4.5' 3.5'	14' 15' 16' 16' 18'	16'+ 17'- 18'- 18'+ 20'-
30' ↓	10' 12' 15' 18' 20' 25'	5.5' 5.0' 5.0' 4.5' 4.0' 3.0'	19' 20' 20' 21' 22' 24'	16'+ 17'- 17'+ 18'+ 19'+ 20'
32' ↓	10' 12' 15' 18' 20' 25'	5.5' 5.0' 4.5' 4.0' 4.0' 2.5'	21' 22' 23' 24' 24' 27'	16'+ 17'- 18'- 19'- 19'+ 20'
36' ↓	10' 12' 15' 18' 20' 25'	5.0' 5.0' 4.5' 4.0' 3.5' 1.5'	26' 26' 27' 28' 29' 33'	17'- 17'+ 18'+ 19'+ 20'- 20'
40' ↓	10' 12' 15' 18' 20' 25'	5.0' 4.5' 4.0' 3.5' 3.0' 1.0'	30' 31' 32' 33' 34' 38'	17'+ 18'+ 19'- 20'- 20' 20'

APPROVED BY	REVISED DATE	CITY OF OLYMPIA	STD. PLAN NO.
	1/2/96	TRAFFIC CIRCLE DIMENSION CHART	4-40C
CITY ENGINEER			

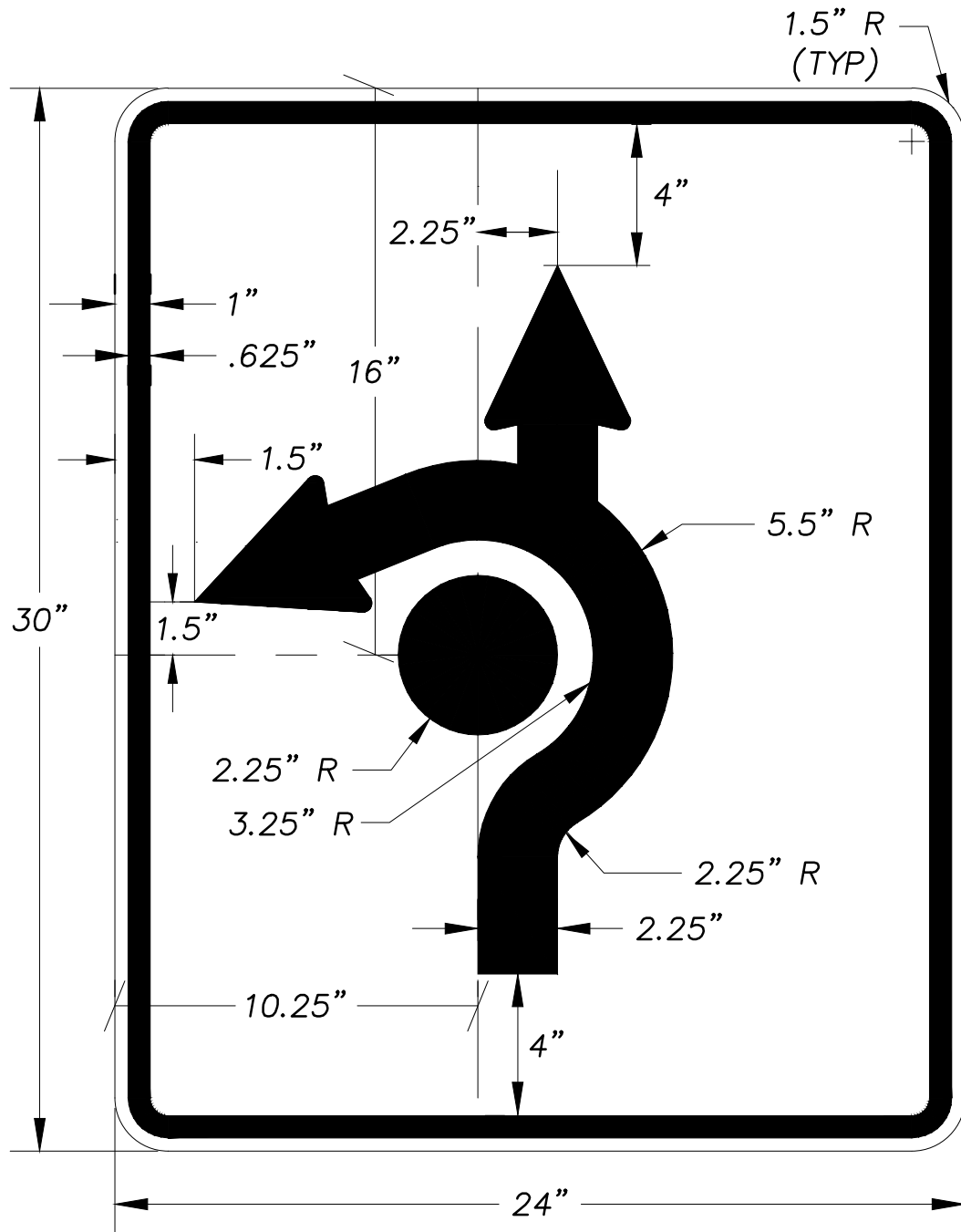

* BLACK LEGEND ON
WHITE BACKGROUND
(REFLECTORIZED)

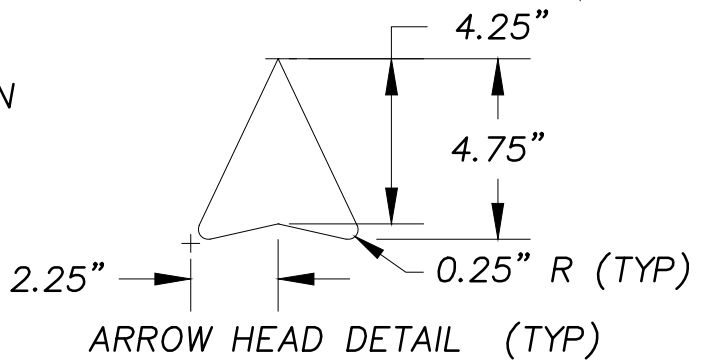

APPROVED BY	REVISED DATE	CITY OF OLYMPIA	STD. PLAN NO.
CITY ENGINEER	12/9/98	TRAFFIC CIRCLE SIGN DETAIL	4-40D

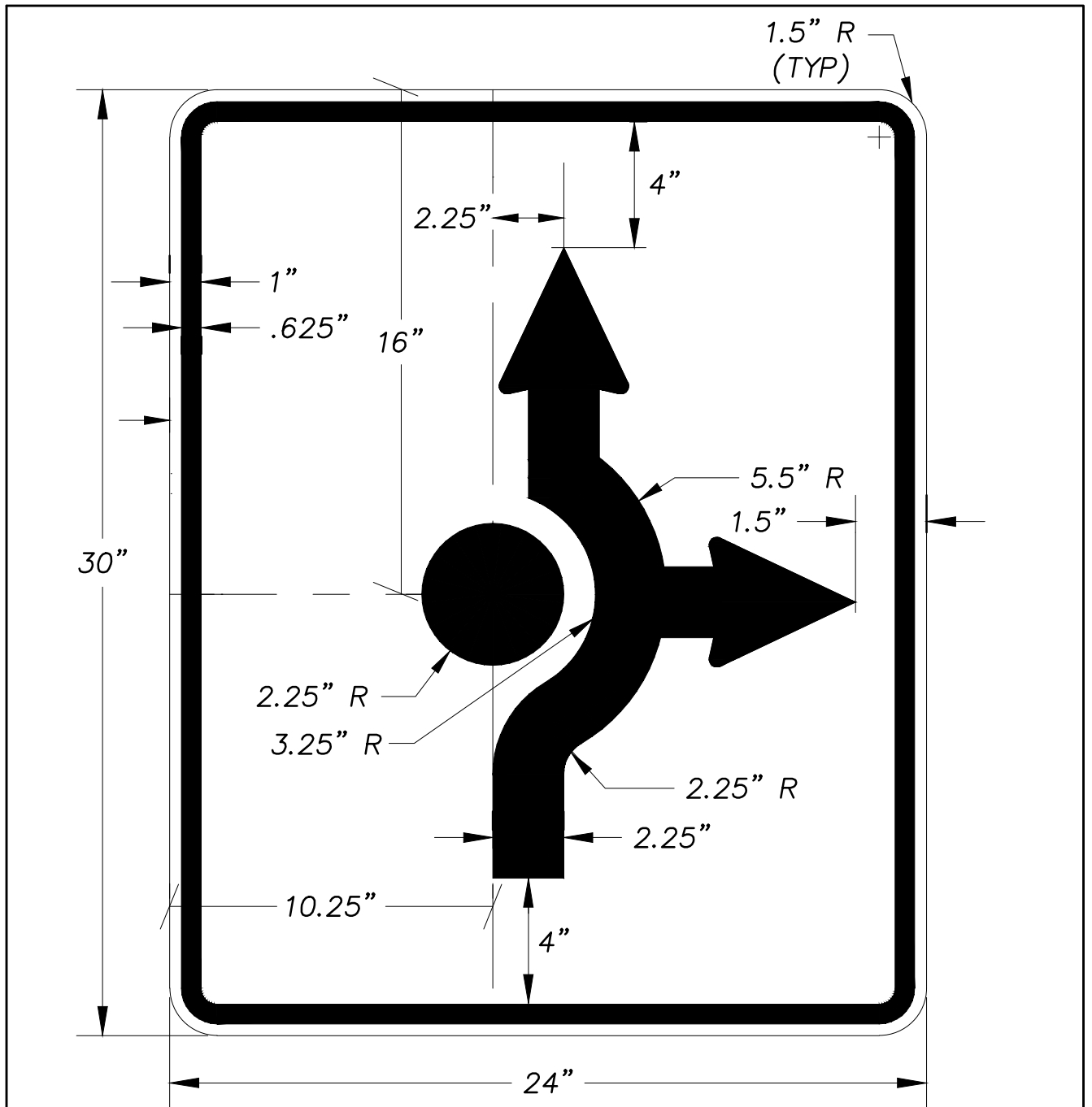

* BLACK LEGEND ON
WHITE BACKGROUND
(REFLECTORIZED)

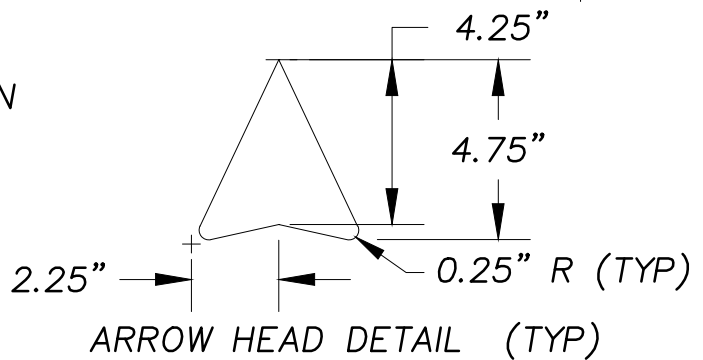

APPROVED BY	REVISED DATE	CITY OF OLYMPIA	STD. PLAN NO.
CITY ENGINEER	12/9/98	TRAFFIC CIRCLE SIGN DETAIL	4-40E

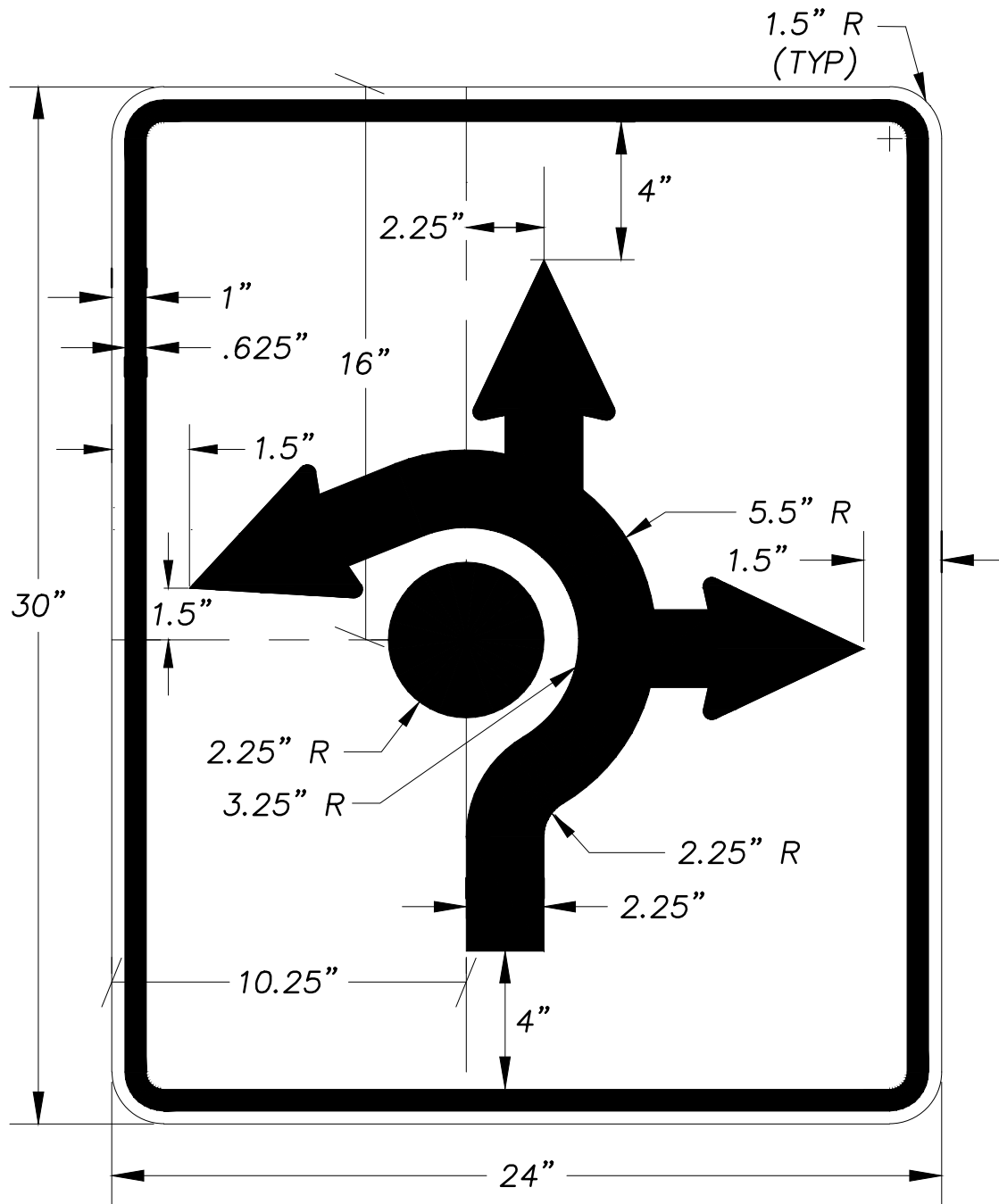

* BLACK LEGEND ON
WHITE BACKGROUND
(REFLECTORIZED)

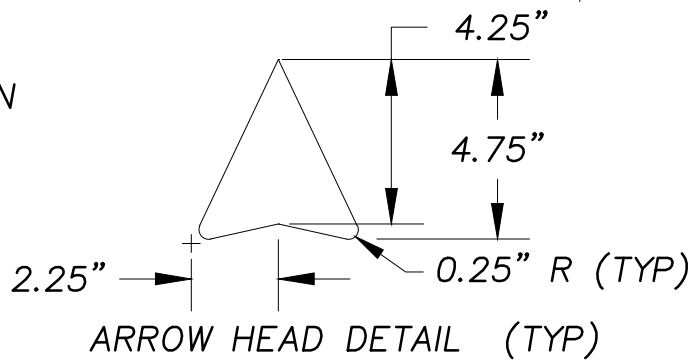

APPROVED BY	REVISED DATE	CITY OF OLYMPIA	STD. PLAN NO.
	12/9/98	TRAFFIC CIRCLE SIGN DETAIL	4-40F
CITY ENGINEER			

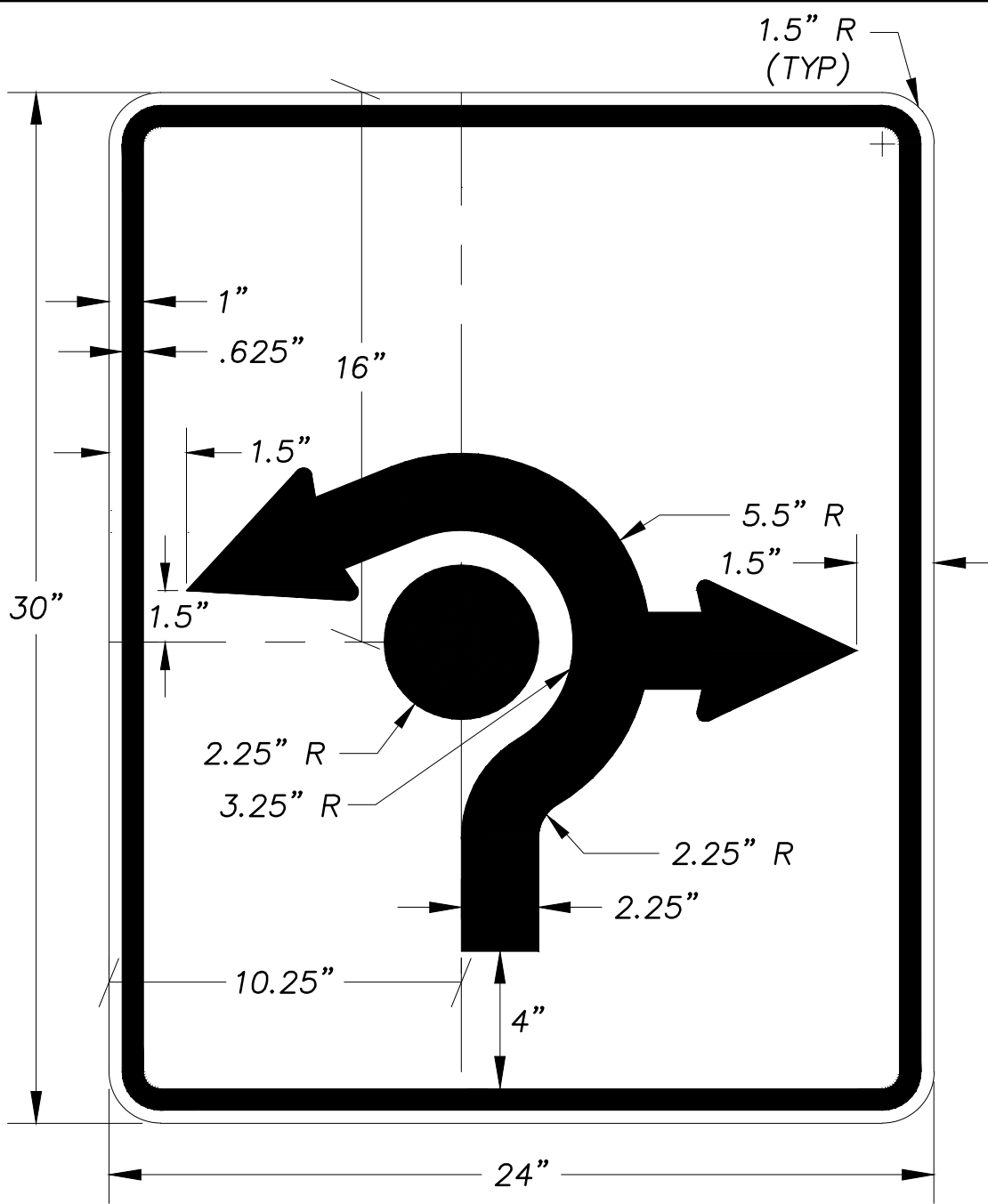

* BLACK LEGEND ON
WHITE BACKGROUND
(REFLECTORIZED)

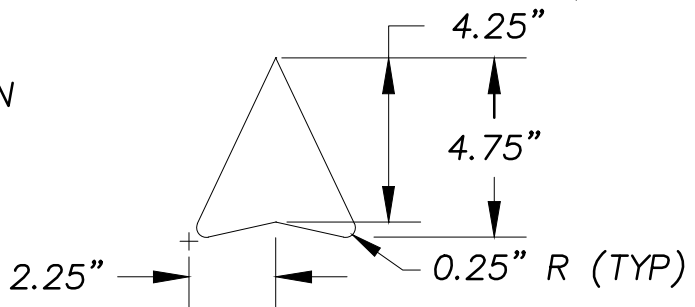

ARROW HEAD DETAIL (TYP)

APPROVED BY	REVISED DATE	CITY OF OLYMPIA	STD. PLAN NO.
	12/9/98	TRAFFIC CIRCLE SIGN DETAIL	4-40G
CITY ENGINEER			

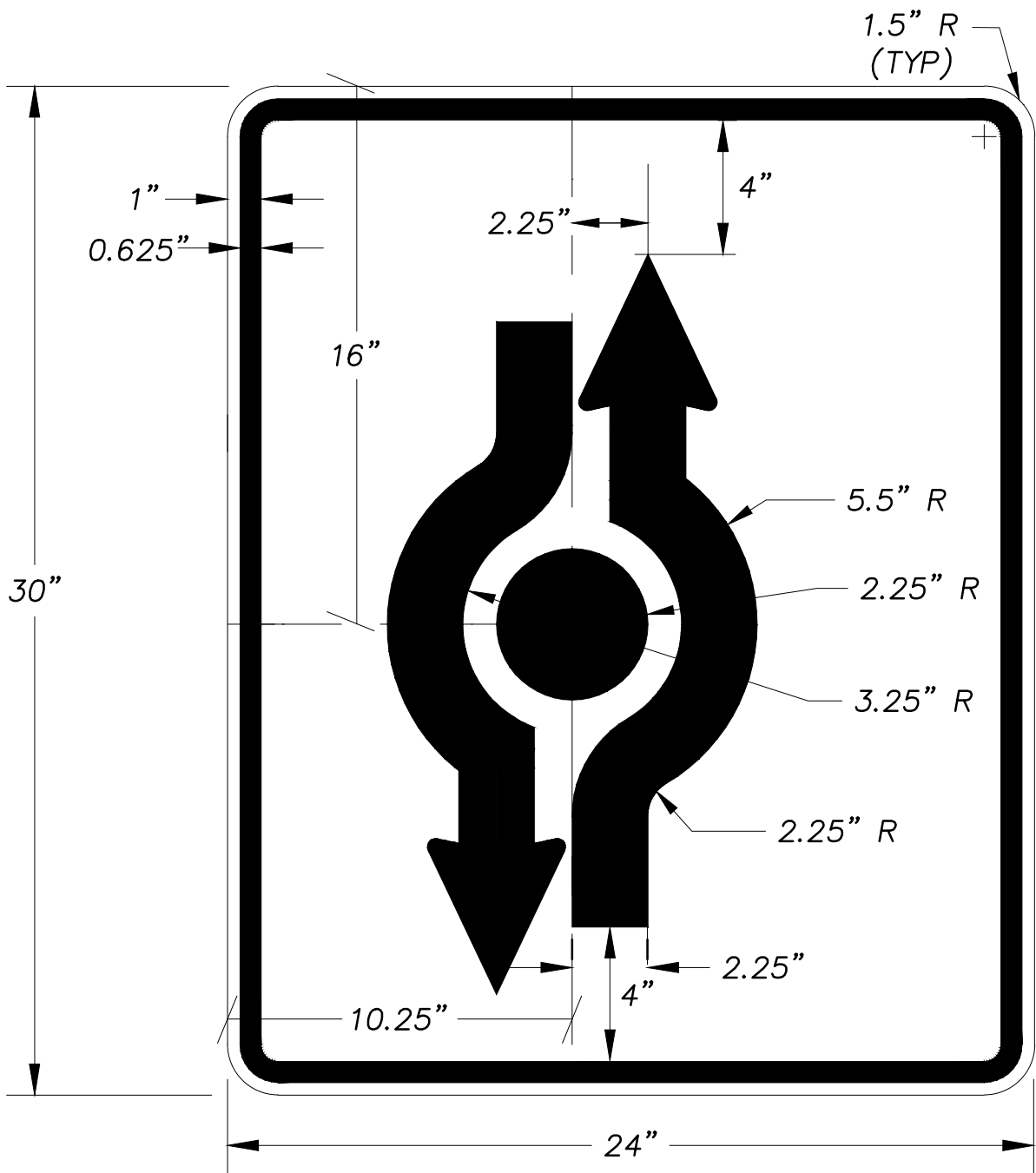

* BLACK LEGEND ON
WHITE BACKGROUND
(REFLECTORIZED)

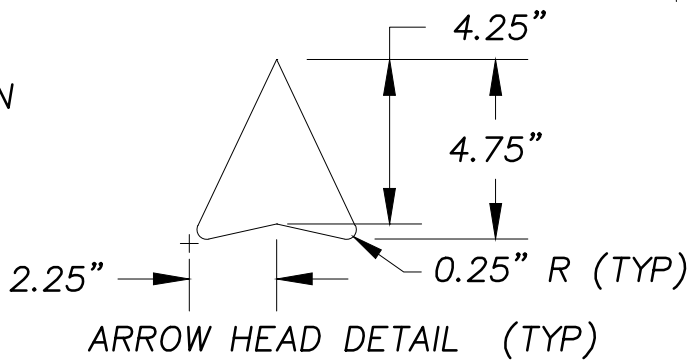

APPROVED BY	REVISED DATE	CITY OF OLYMPIA	STD. PLAN NO.
	12/9/98	TRAFFIC CIRCLE SIGN DETAIL	4-40H
CITY ENGINEER			

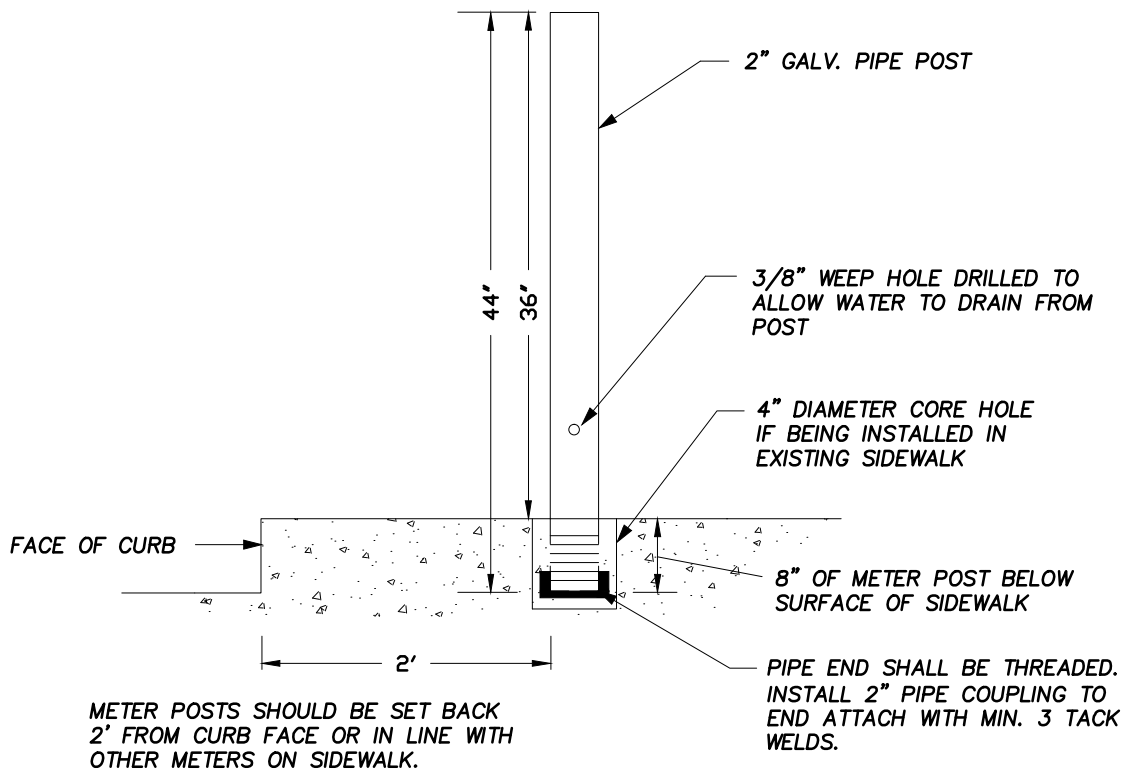

TYPICAL POST INSTALLATION IN EXISTING SIDEWALK AREA

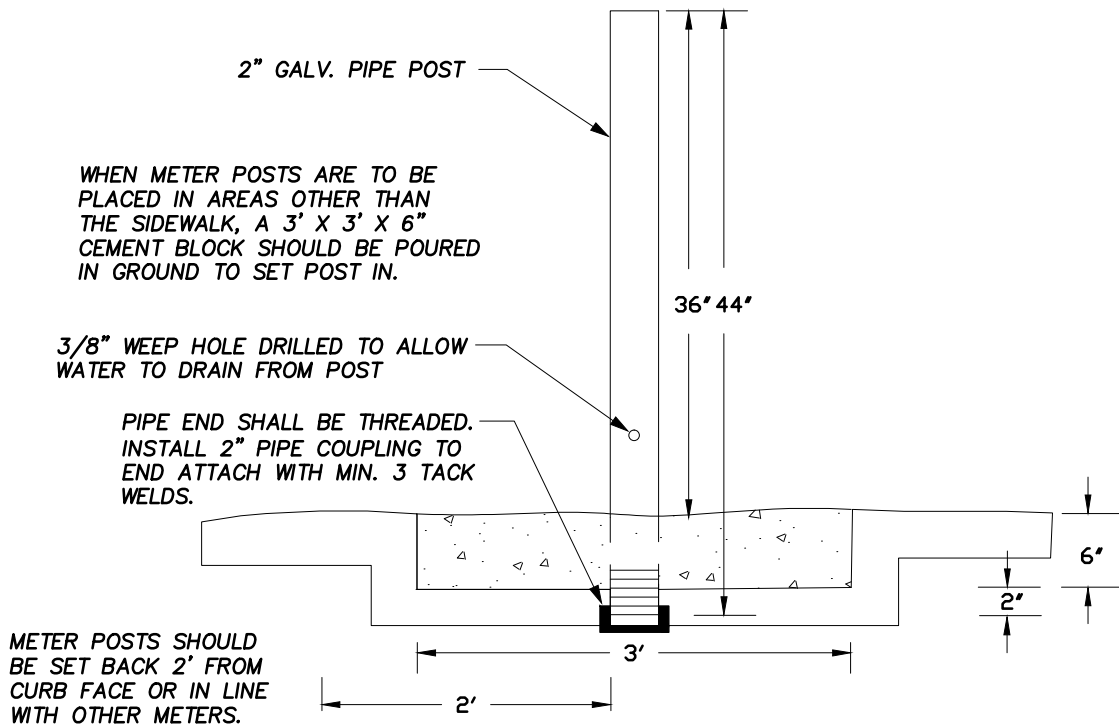

TYPICAL POST INSTALLATION OTHER THAN SIDEWALK AREA

APPROVED BY	REVISED DATE	CITY OF OLYMPIA	STD. PLAN NO.
	9/19/2012	TYPICAL PARKING METER POST INSTALLATION	4-41A
CITY ENGINEER			

SINGLE HEAD METER POSTS SHOULD BE SET AT THE HEAD OF THE PARKING STALL IN LINE WITH ANY PARKING STALL MARKINGS. (PARKING "L")

DOUBLE HEAD METER POSTS ARE TO BE PLACED BETWEEN PARKING STALLS, IN LINE WITH ANY PARKING STALL MARKINGS. (PARKING "T")

TYPICAL:
PAINT CURB
YELLOW TO
CORNER OR
DRIVEWAY AS
MARKED BY
ENGINEER IN
THE FIELD



SINGLE HEAD
METER

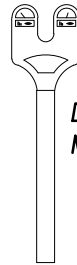

DOUBLE HEAD
METER

TYPICAL:
PAINT CURB
YELLOW TO
CORNER OR
DRIVEWAY AS
MARKED BY
ENGINEER IN
THE FIELD



MAINTAIN MINIMUM UNOBSTRUCTED SIDEWALK WIDTH TO COMPLY WITH ADA STANDARDS.

IF UNSURE ABOUT METER PLACEMENT, CONTACT PROJECT INSPECTOR.

TYPICAL PARKING STALL LAYOUT

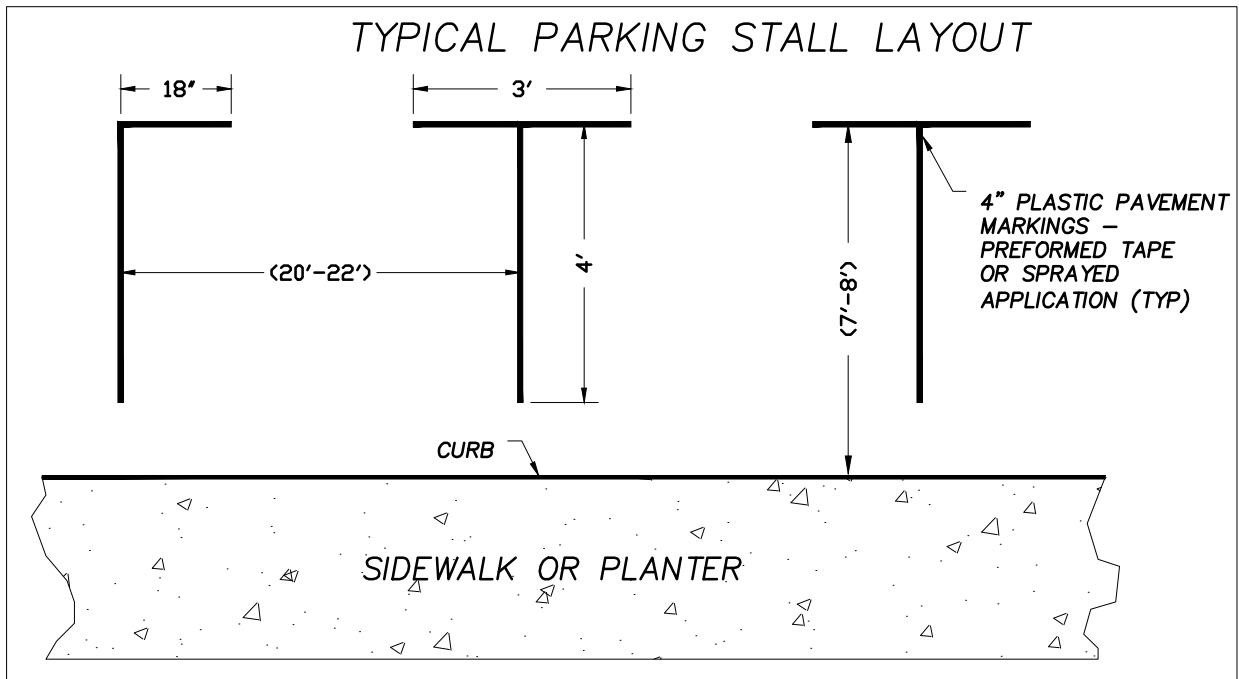

N.T.S.

APPROVED BY	REVISED DATE	CITY OF OLYMPIA	STD. PLAN NO.
	10/27/08	TYPICAL PARKING METER POST PLACEMENT AND PARKING STALL LAYOUT	4-41B
CITY ENGINEER			

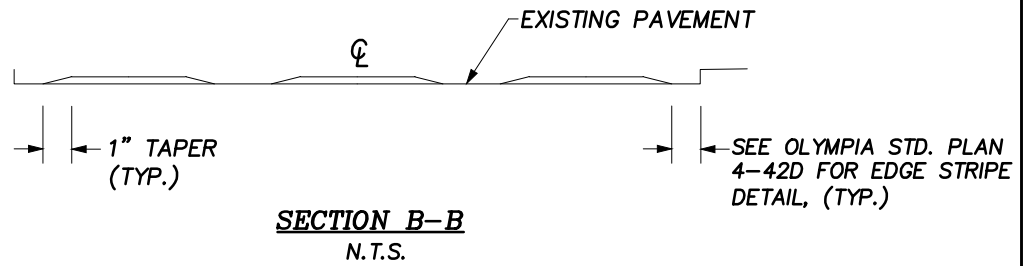
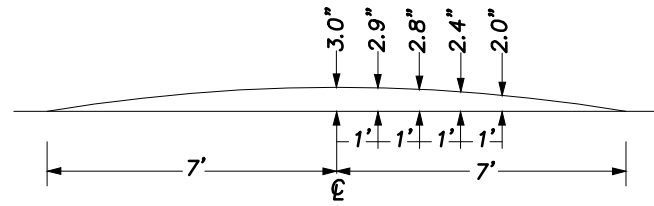
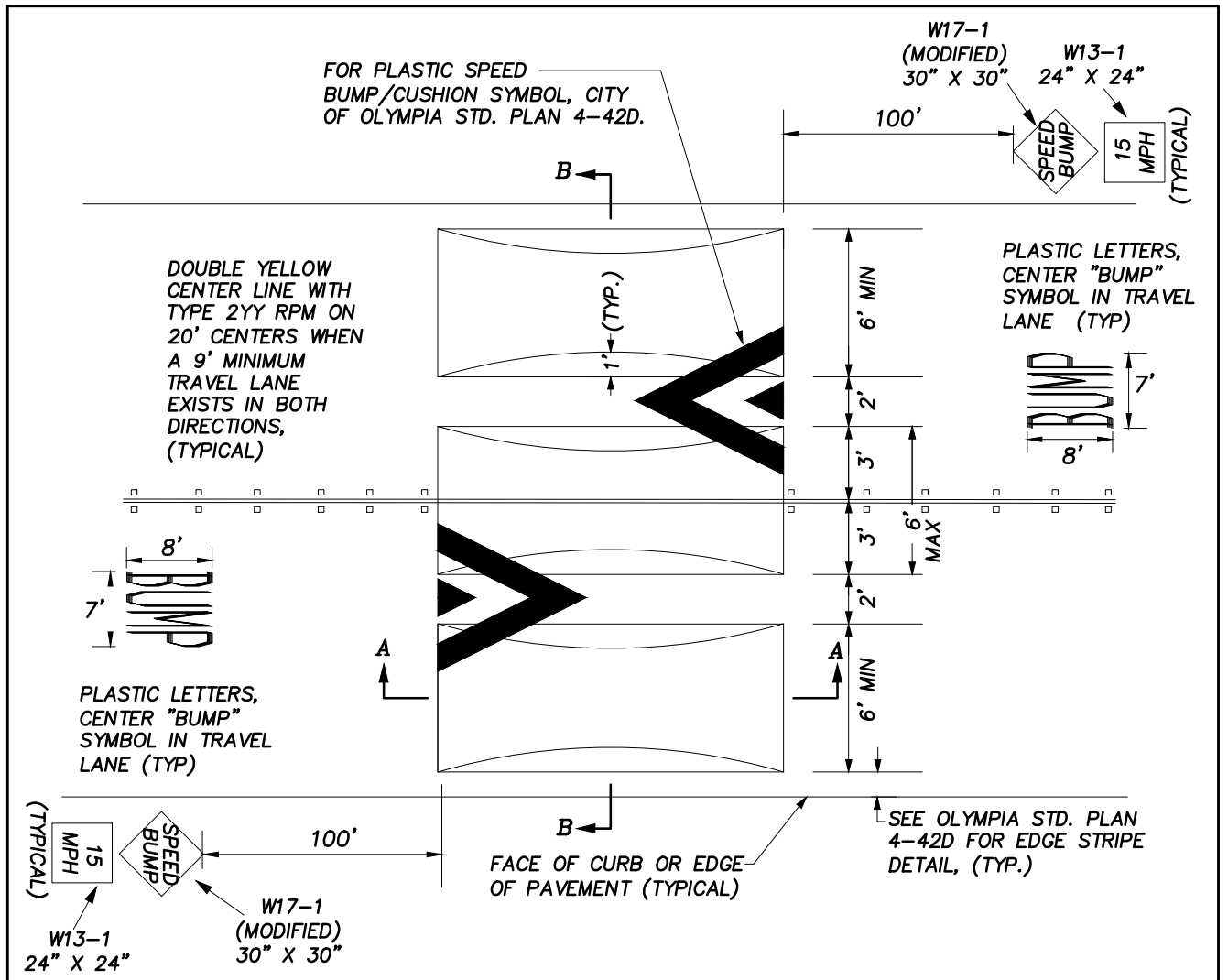

APPROVED BY	REVISED DATE	CITY OF OLYMPIA	STD. PLAN NO.
CITY ENGINEER	11/14/2011	SPEED CUSHION	4-42A

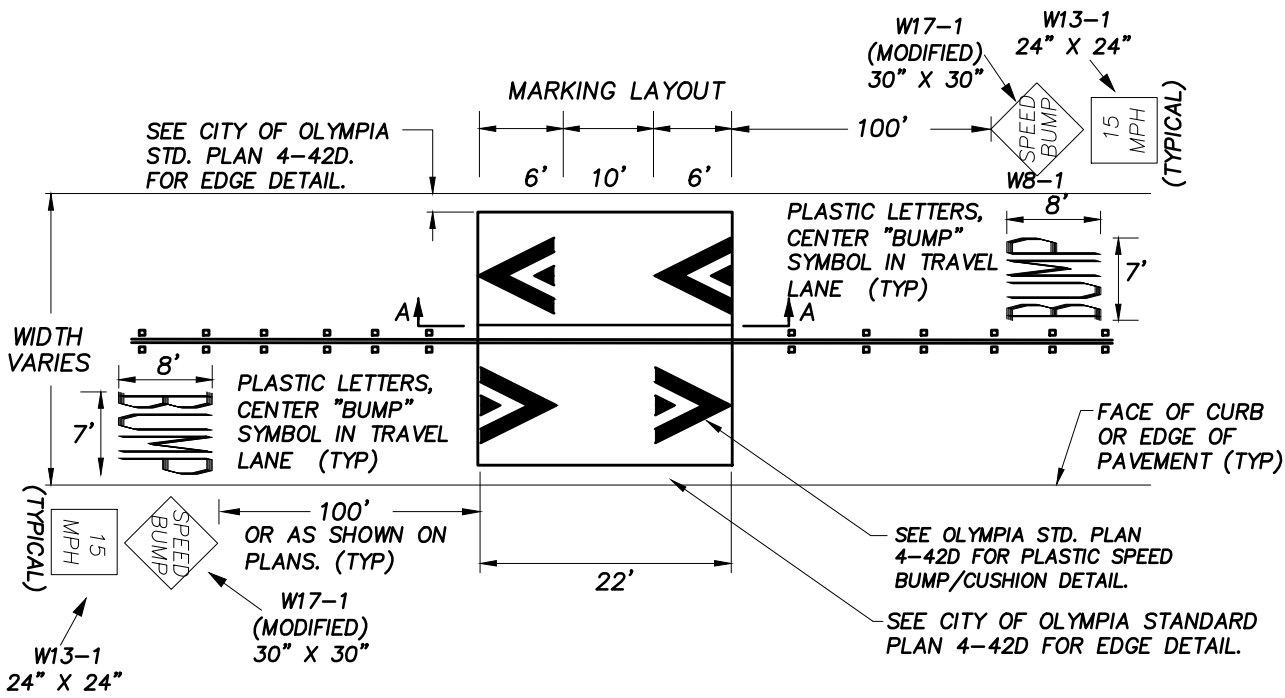

NOTE:

DOUBLE YELLOW CENTER LINE WITH TYPE 2YY RPM'S ON 20 FOOT CENTERS WHEN A 9 FOOT MINIMUM TRAVEL LANE EXISTS IN BOTH DIRECTIONS. (TYPICAL)

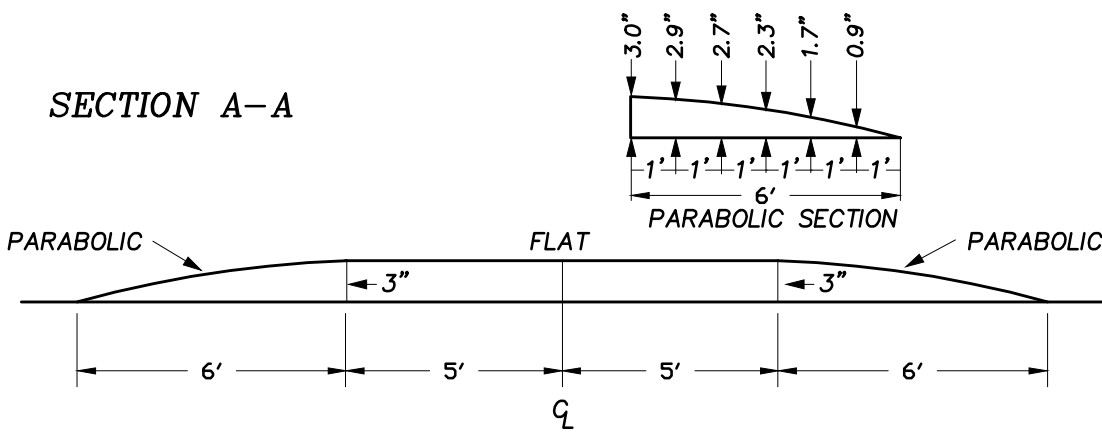

APPROVED BY	REVISED DATE	CITY OF OLYMPIA 22' SPEED BUMP	STD. PLAN NO.
CITY ENGINEER	11/14/2011		4-42B

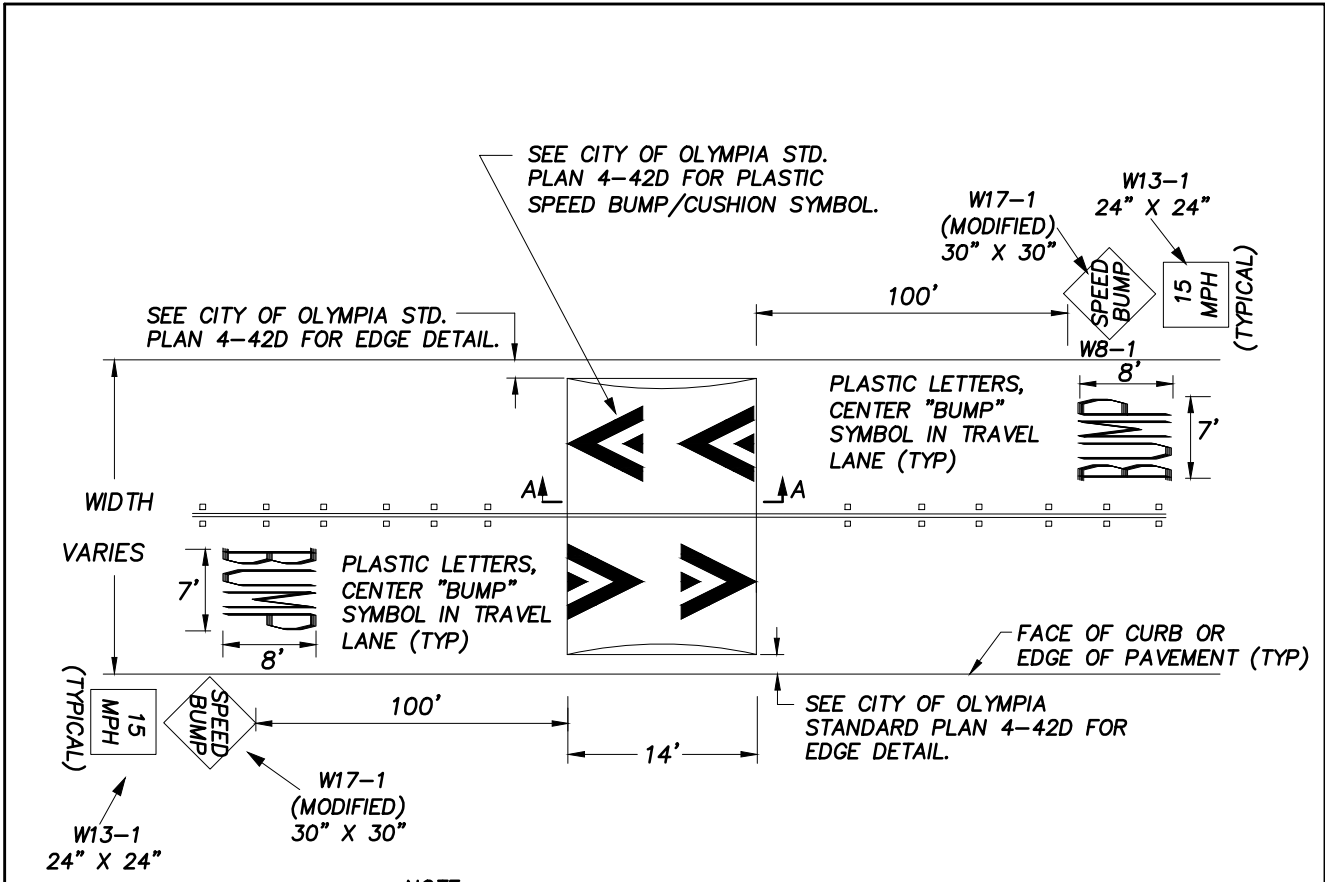

NOTE:
 DOUBLE YELLOW CENTER LINE WITH TYPE 2YY RPM'S ON 20 FOOT CENTERS WHEN A 9 FOOT MINIMUM TRAVEL LANE EXISTS IN BOTH DIRECTIONS. (TYPICAL)

SECTION A-A

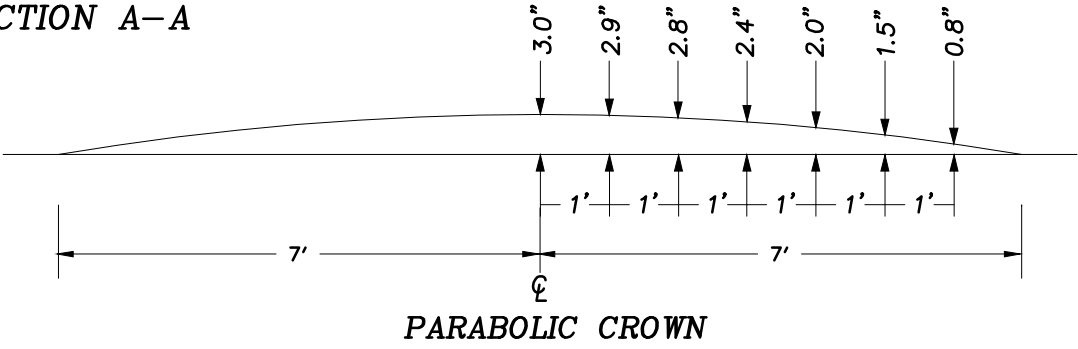

APPROVED BY	REVISED DATE	CITY OF OLYMPIA	STD. PLAN NO.
	11/14/2011	14' SPEED BUMP	4-42C
CITY ENGINEER			

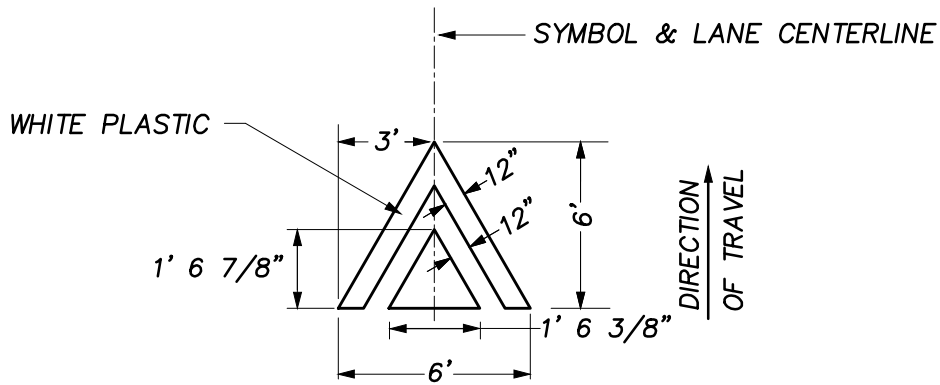

PLASTIC SPEED BUMP/CUSHION SYMBOL

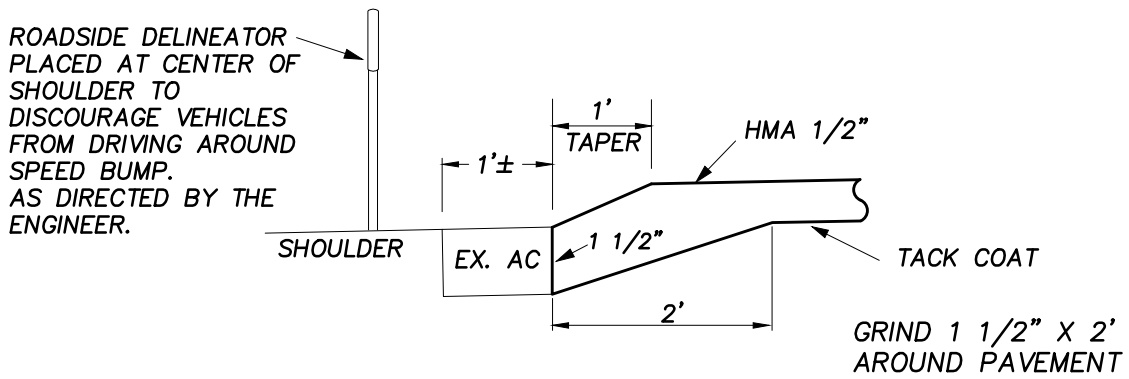

EDGE DETAIL FOR STREETS WITHOUT CURBS

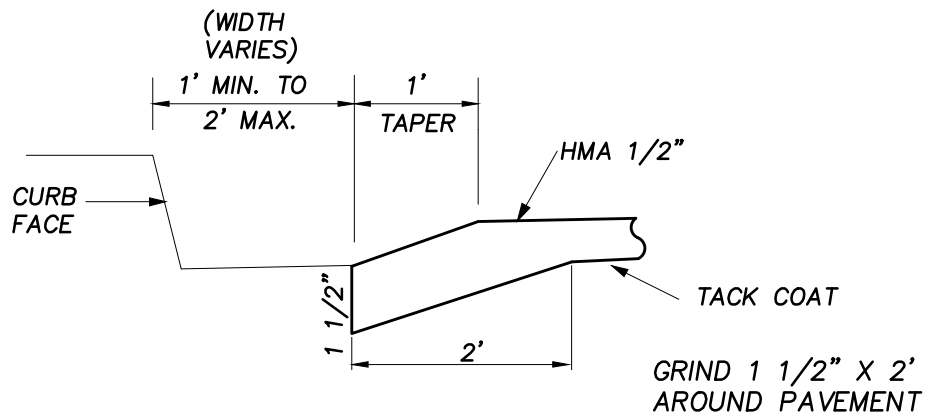

EDGE DETAIL FOR STREETS WITH CURB

APPROVED BY	REVISED DATE	CITY OF OLYMPIA	STD. PLAN NO.
	11/14/2011	SPEED BUMP/CUSHION DETAILS	4-42D
CITY ENGINEER			

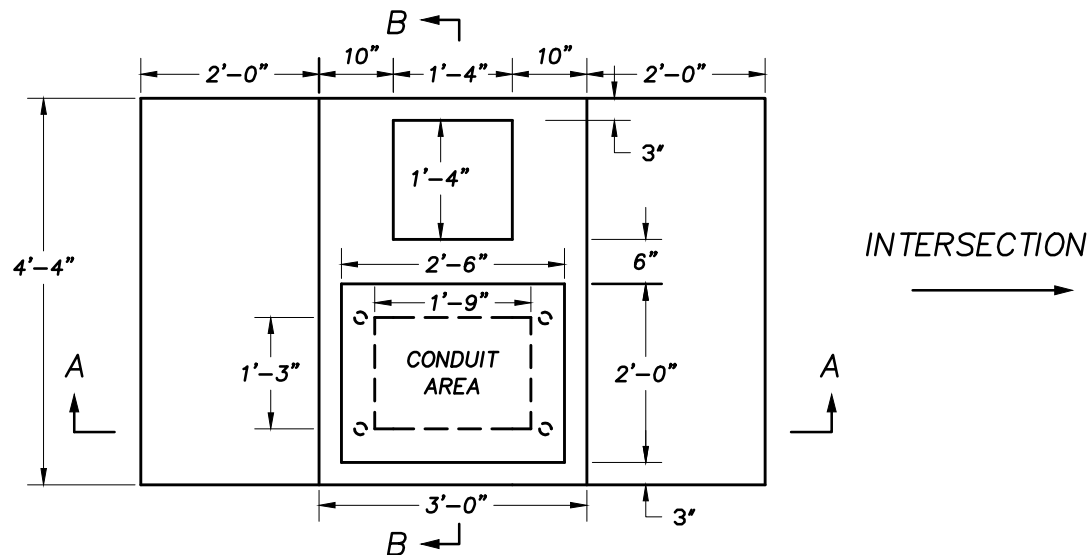

SECTION A-A

SECTION B-B

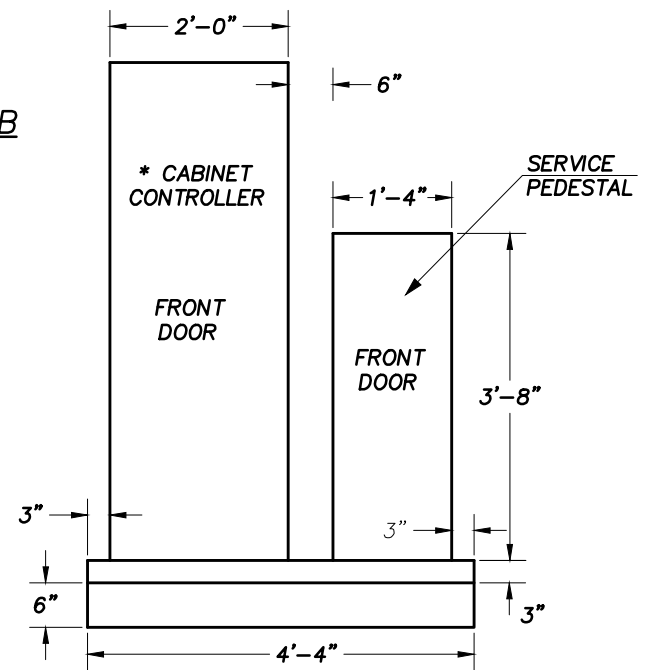
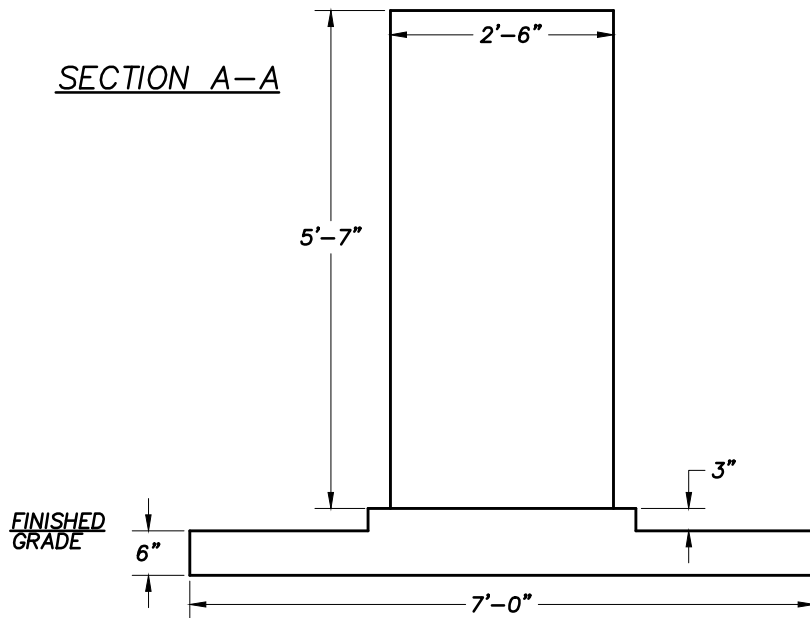

* BOLT PATTERNS AS PER MANUFACTURER'S RECOMMENDATION

APPROVED BY	REVISED DATE	CITY OF OLYMPIA TYPICAL PEDESTAL FOR CONTROLLER CABINET & SERVICE	STD. PLAN NO.
CITY ENGINEER	12/4/98		4-43

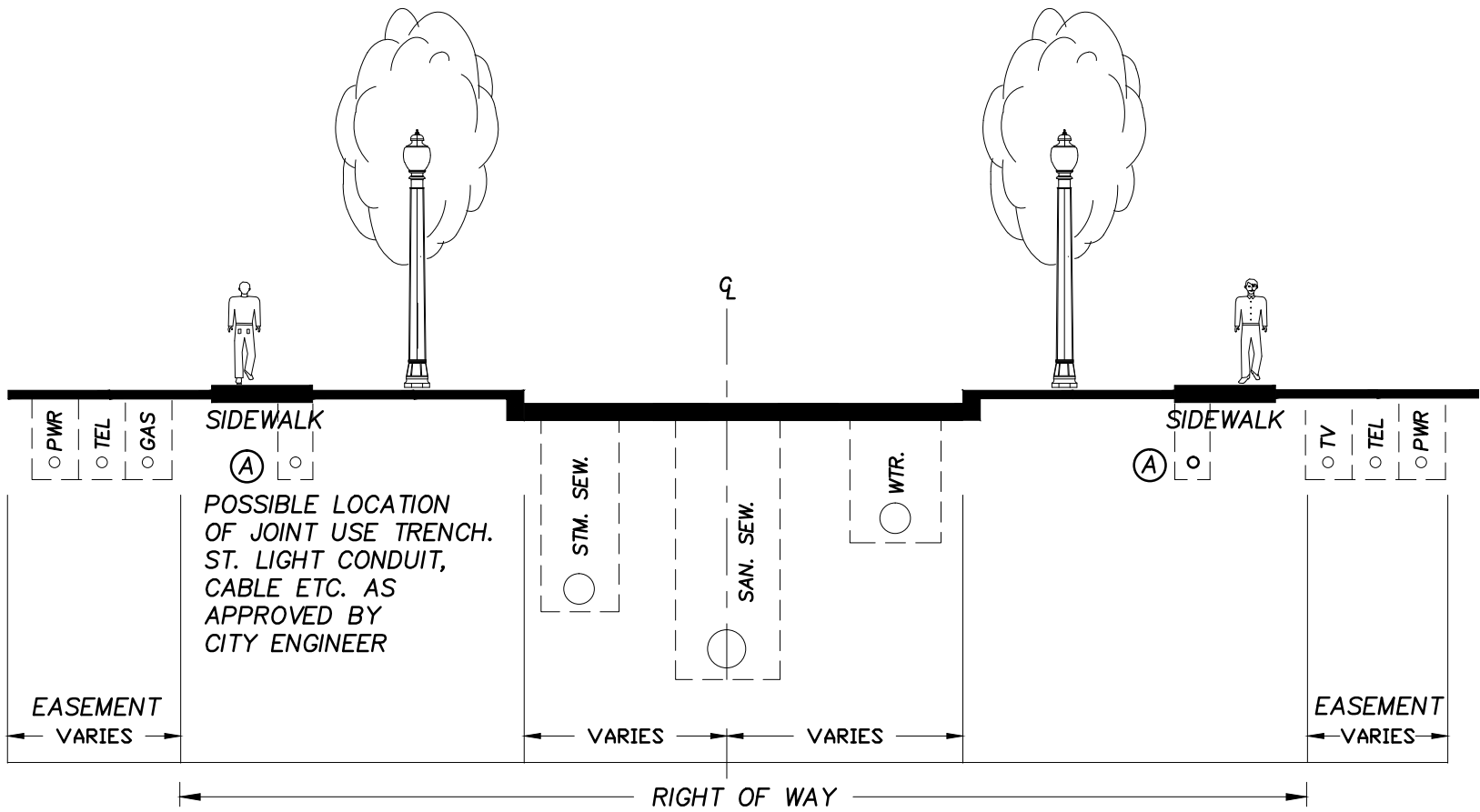

NOTE:
 1. SEE APPROPRIATE ROADWAY CROSS-SECTION FOR DIMENSIONS.

APPROVED BY	REVISED DATE	CITY OF OLYMPIA	STD. PLAN NO.
CITY ENGINEER	2/26/08		4-44
		STANDARD UTILITIES LOCATION SCHEMATIC	

EDGE OF ROAD (NO SIDEWALK)

* DISTANCE FROM EDGE OF ROAD MAY VARY DUE TO OBSTACLES.

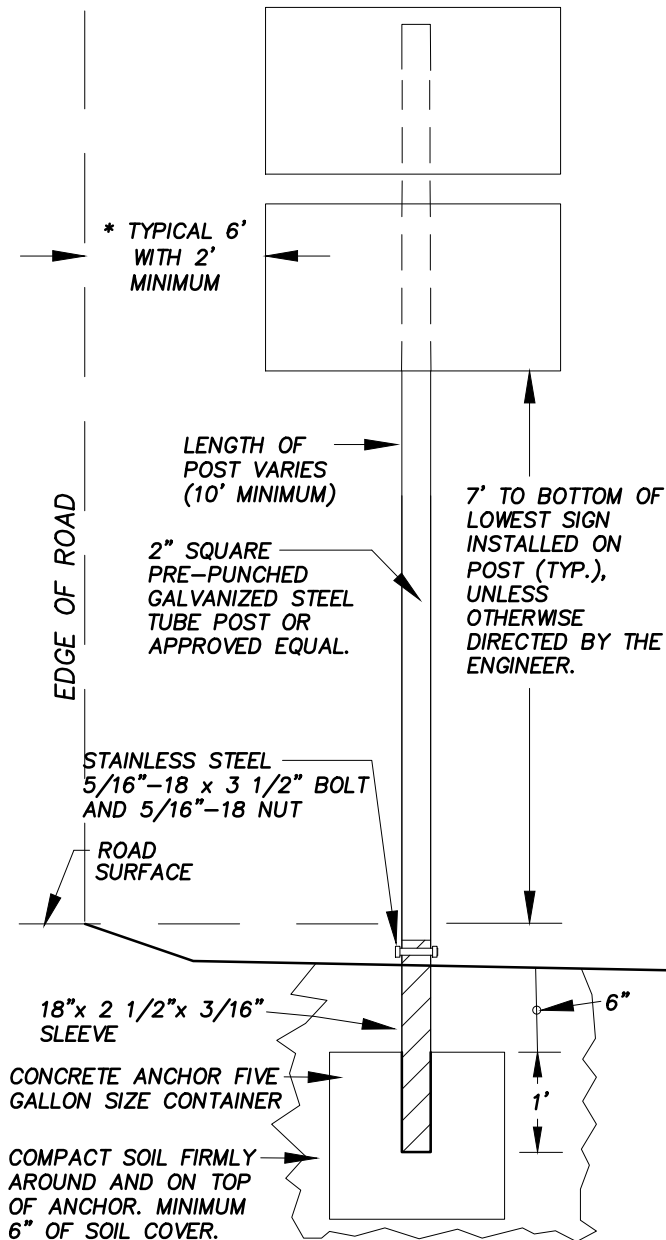

SIDEWALK INSTALLATION

** PREFERRED LOCATION IS BEHIND SIDEWALK, BUT IF UNAVAILABLE DUE TO OBSTRUCTIONS SUCH AS BUILDINGS OR STREET TREES, INSTALL AS INDICATED BELOW. IF SIGN IS PLACED IN SIDEWALK, SIGN EDGE SHALL BE A MINIMUM OF 2' FROM CURB FACE.

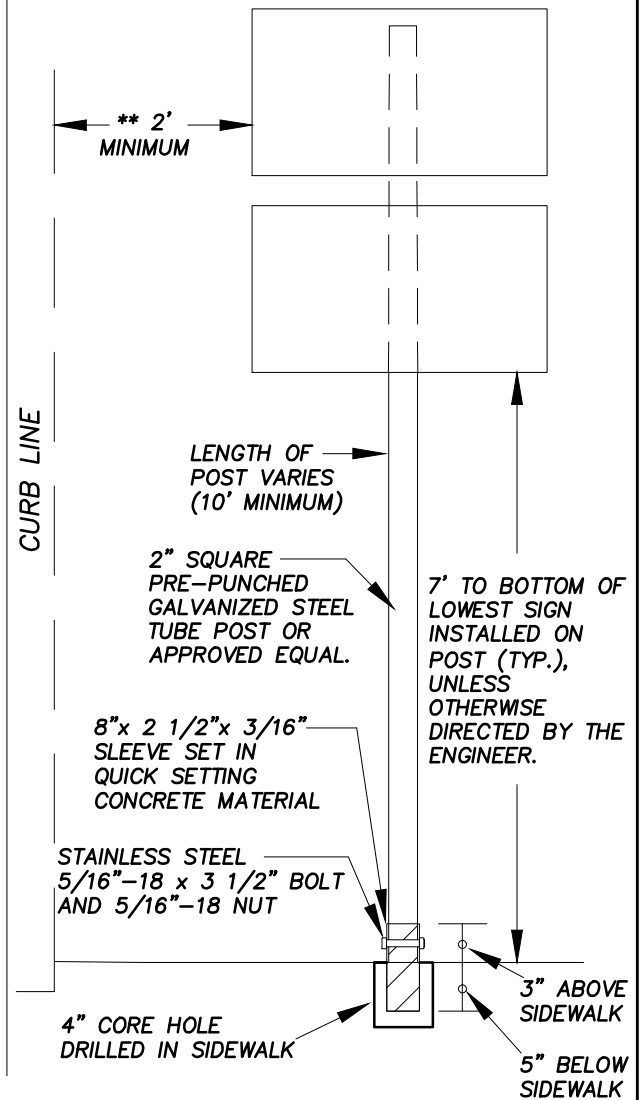

TYPICAL SIGN INSTALLATION NOTES:

- SIGN POSTS SHALL BE 2" SQUARE, PRE-PUNCHED GALVANIZED STEEL TUBING. PRE-PUNCHED HOLES SHALL BE 7/16TH INCH DIAMETER SPACED 1 INCH ON CENTER. SIGN POST SHALL BE 12 GAUGE.
- SIGN POSTS INSTALLED IN A SIDEWALK SHALL BE MOUNTED IN A 2 1/2" SQUARE OUTSIDE DIMENSION X 8" LONG, 3/16" WALL THICKNESS, GALVANIZED STEEL TUBING SLEEVE. THE SLEEVE SHALL BE PREDRILLED WITH AN 11/32" HOLE DRILLED THROUGH 1 1/2" FROM THE TOP OF THE SLEEVE.
- SIGN POSTS INSTALLED IN SOIL SHALL BE MOUNTED IN A 2 1/2" SQUARE OUTSIDE DIMENSION X 18" LONG, 3/16" WALL THICKNESS, GALVANIZED STEEL TUBING SLEEVE SET IN A FIVE-GALLON SIZE CONTAINER, OR EQUAL, OF CLASS C CEMENT CONCRETE FOR A FOUNDATION.
- STAINLESS STEEL BOLTS, NUTS AND FLAT WASHERS SHALL BE USED TO ATTACH SIGNS TO THE 2" SQUARE, PRE-PUNCHED GALVANIZED STEEL TUBING SIGN POSTS. 5/16"-18 X 3" BOLTS, 5/16"-18 NUTS AND 5/16" FLAT WASHERS SHALL BE USED. THE 5/16" FLAT WASHER SHALL BE PLACED BETWEEN THE SIGN AND BOLT HEAD WHEN ATTACHING TO SIGN POST.

APPROVED BY	REVISED DATE	CITY OF OLYMPIA TYPICAL SIGN INSTALLATION DETAIL	STD. PLAN NO.
CITY ENGINEER	4/25/2011		4-45

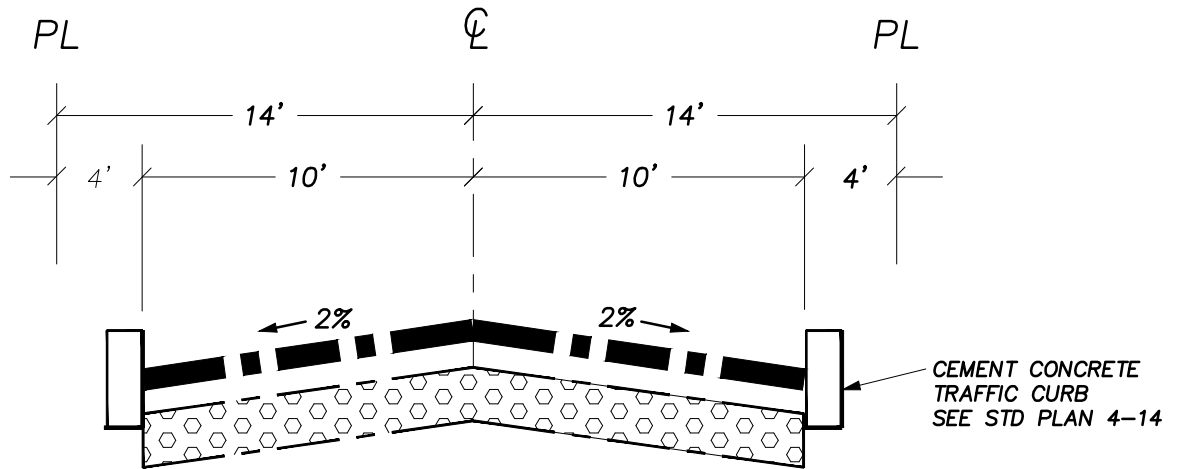

PRIVATE ACCESS LANE

NO SCALE

1. PROVIDE DRIVEWAY APPROACH TO ACCESS LANE PER STANDARD PLAN #4-7.
2. SIGN "NO OUTLET" PER STD. PLAN 4-45.
3. STRUCTURAL SECTION PER PAVEMENT DESIGN STANDARD PLAN #4-6A.

APPROVED BY	REVISED DATE	CITY OF OLYMPIA	STD. PLAN NO.
	2/26/08	PRIVATE ACCESS LANE	4-46
CITY ENGINEER			

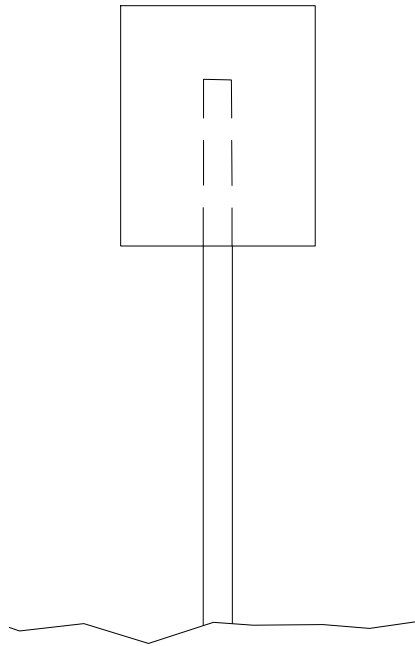

FOR INSTALLATION REFER
TO STD. PLAN 4-45.

NOTES:

1. SIGN SHALL BE A MINIMUM OF 12 INCHES X 18 INCHES.
2. SIGN SHALL BE A WHITE REFLECTIVE BACKGROUND WITH RED LETTERING AND LINES.
3. PLACEMENT SHALL BE EVERY 100' ON CENTER, ALTERNATING SPACING IF LOCATED ON BOTH SIDES OF STREET.
4. FOR INSTALLATION FOLLOW STD. PLAN 4-45.

APPROVED BY	REVISED DATE	CITY OF OLYMPIA	STD. PLAN NO.
	4/12/00	FIRE LANE SIGN	4-47
CITY ENGINEER			

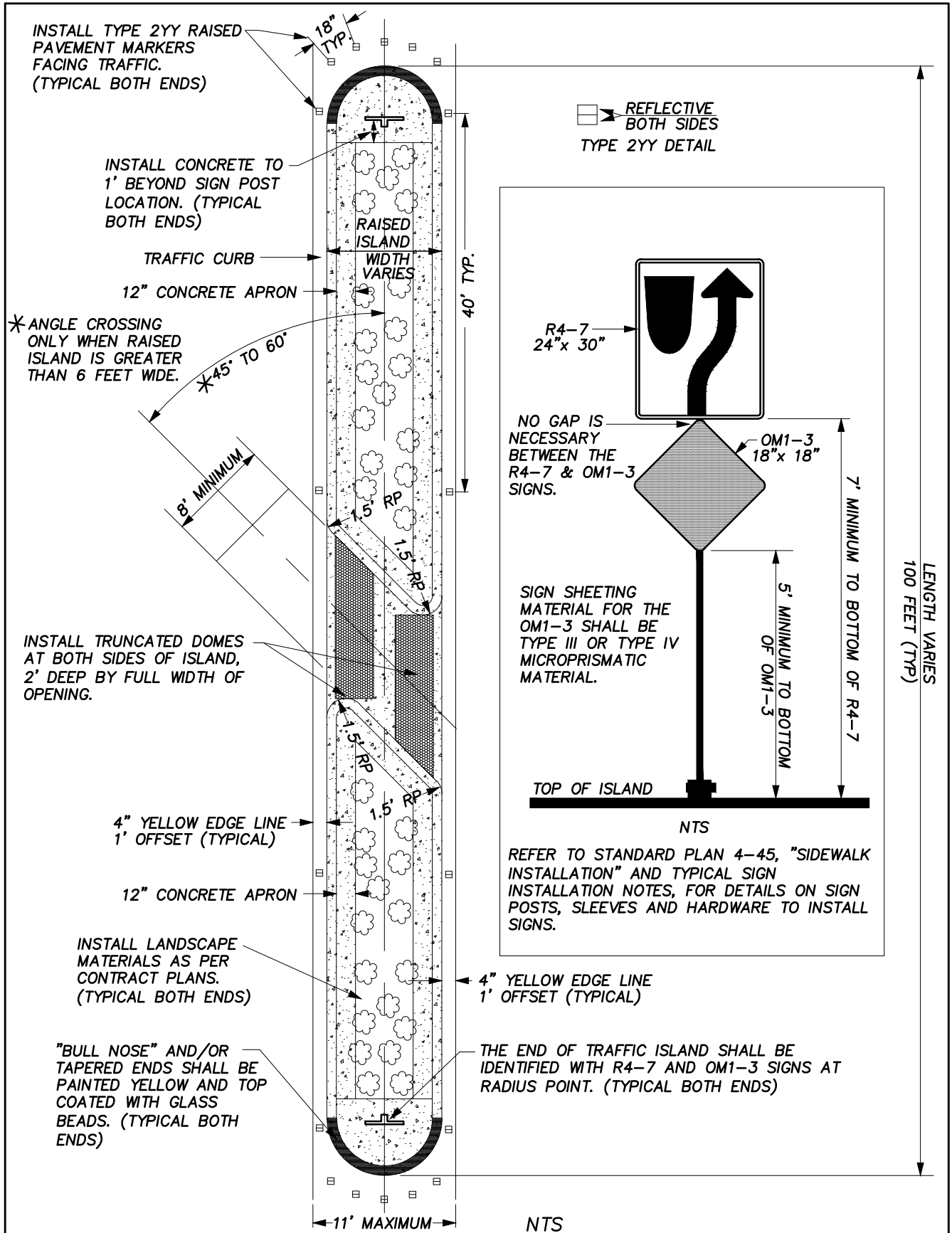

APPROVED BY	REVISED DATE	CITY OF OLYMPIA PEDESTRIAN REFUGE LANDSCAPED ISLAND DETAILS	STD. PLAN NO.
	12/09/2011		4-48
CITY ENGINEER			

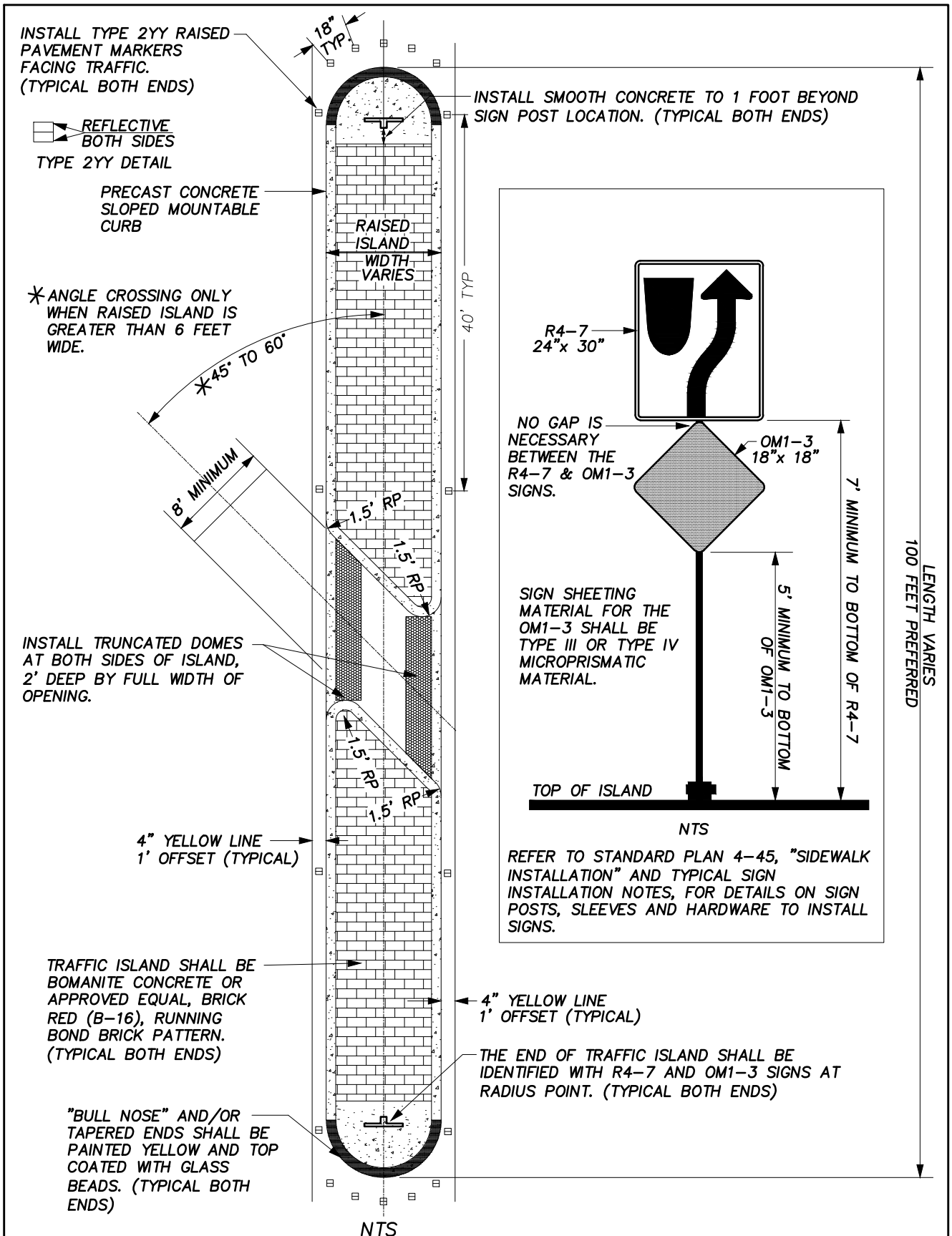

APPROVED BY	REVISED DATE	CITY OF OLYMPIA PEDESTRIAN REFUGE CONCRETE ISLAND DETAILS	STD. PLAN NO.
	9/26/2011		4-48A
CITY ENGINEER			

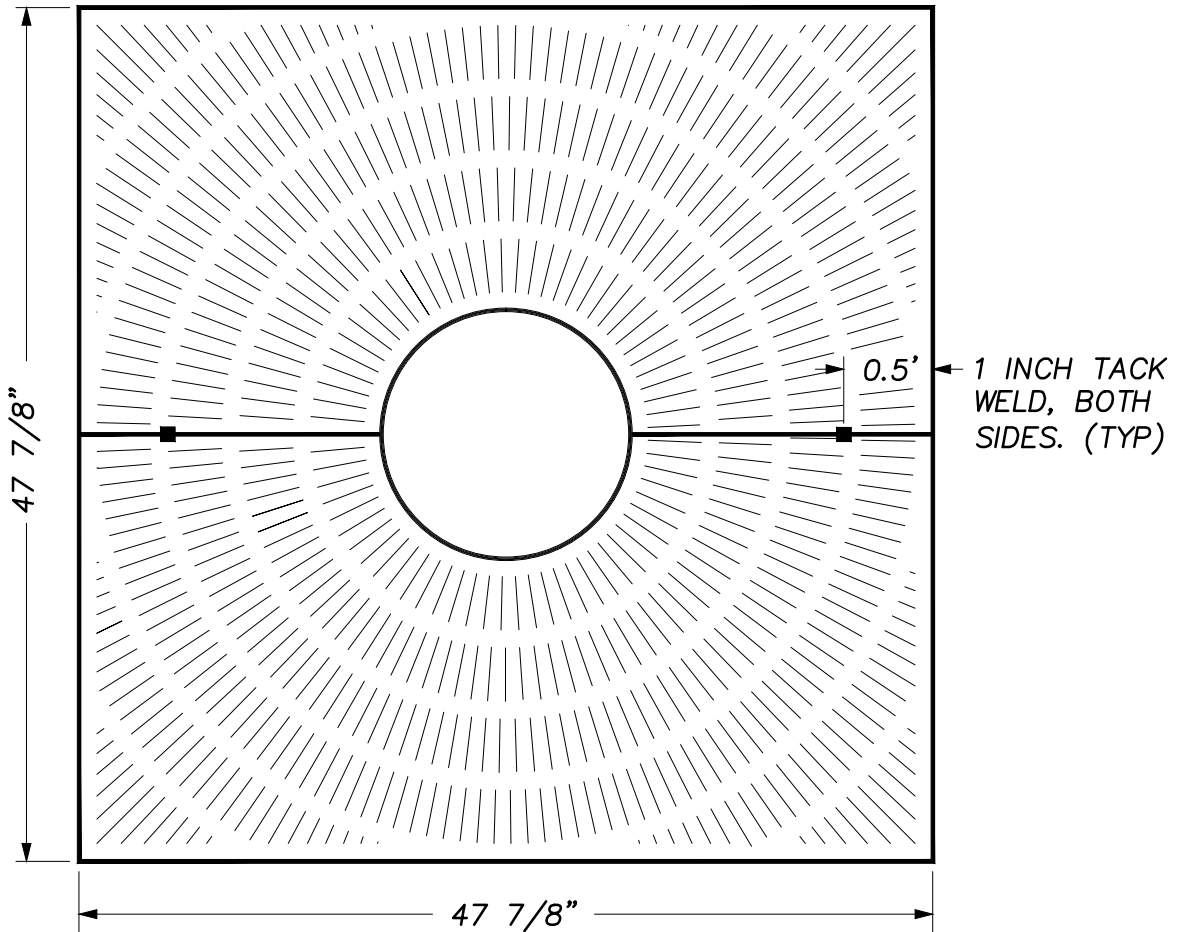

Notes:

1. Standard 16 inch opening.
2. Cast in two pieces.
3. No opening greater than 3/8 inch.
4. Grate is 1 inch thick with 1 1/4 inch thick support ribs.
5. Knockouts at 22 inches and 33 inches.
6. 1 Inch "Tack" or "Spot" weld, both sides.
7. Alternate sizes and patterns are acceptable if above criteria is met and approved by the City Urban Forester.
8. Grates shall be installed with brackets and or / frames per the Manufacture's recommendation.
9. Grate with frame to be installed flush with sidewalk.
10. All grates shall meet ADA Standards.
11. Tree grate shall be placed adjacent to curb, within the the sidewalk.

N.T.S.

APPROVED BY	REVISED DATE	CITY OF OLYMPIA	STD. PLAN NO.
	8/03/2012	TREE GRATE	4-49
CITY ENGINEER			