

2013 Wastewater Management Plan

October 2013

olympiawa.gov/plans



2013 Wastewater Management Plan

Contacting Us

Mail

City of Olympia
Public Works
P.O. Box 1967
Olympia, WA 98507-1967



Staff Contact

Andy Haub, P.E., Planning and Engineering Manager
360.753.8475
plans@ci.olympia.wa.us
olympiawa.gov/plans

YOU can make a difference by viewing this plan online rather than printing.

October 2013

The City of Olympia is committed to the non-discriminatory treatment of all persons in the employment and the delivery of services and resources.

olympiawa.gov/plans

Acknowledgements

This plan was produced by City of Olympia Public Works staff

Andy Haub

Steve Sperr

Diane Utter

Rich Hoey

Clark Halvorson

Gary Franks

Doug Floyd

Jeannine Stewart

With guidance and review by

Olympia City Council

Olympia's Utility Advisory Committee

And assistance from

Dorothy P. Craig & Associates

FCS Group

For more information on this plan, please contact:

Andy Haub - 360.753.8475

ahaub@ci.olympia.wa.us

City of Olympia

Water Resources Program

P.O. Box 1967

Olympia, WA 98507

Table of Contents for the 2013 Wastewater Management Plan

Chapter 1 - Executive Summary of the Plan

- 1.1 Overall Vision
- 1.2 Challenges
- 1.3 Summary of Goals, Objectives and Strategies
- 1.4 Summary of Capital Projects

Chapter 2 - Background Information

- 2.1 Sewer Service Area
- 2.2 Population and Land Use
- 2.3 Wastewater Flows
- 2.4 Physical Setting
- 2.5 State and Federal Regulations
- 2.6 Local Regulations and Design Standards
- 2.7 Related Plans
- 2.8 Governmental Agreements

Chapter 3 - Current Wastewater System

- 3.1 Gravity Collection System
- 3.2 Lift Stations and Force Mains
- 3.3 STEP Systems
- 3.4 Grinder Pumps Systems
- 3.5 Neighboring Jurisdictions
- 3.6 LOTT Clean Water Alliance
- 3.7 Pretreatment

Chapter 4 - Onsite Sewage Systems

- 4.1 Types of Onsite Systems
- 4.2 Public Health Risks of OSS in Urban Areas
- 4.3 Proximity of OSS to Olympia Sewer System
- 4.4 Potential Costs of Converting OSS to Public Sewer
- 4.5 Current Regulations

Chapter 5 - Watershed Basin Characterization

- 5.1 Central Watershed Basin
- 5.2 Kettles Watershed Basin
- 5.3 Northeast Watershed Basin
- 5.4 Southeast Watershed Basin
- 5.5 Southwest Watershed Basin
- 5.6 Northwest Watershed Basin

Chapter 6 - Management Programs

- 6.1 Organizational Relationships
- 6.2 Staff and Cores Services
- 6.3 Planning, Policy and Program Management
- 6.4 Capital Facilities Planning
- 6.5 Operations and Maintenance
- 6.6 Development Review, Technical Assistance and Code Enforcement
- 6.7 Monitoring, Research and Evaluation
- 6.8 Public Involvement and Education

Chapter 7 - Operations and Maintenance

- 7.1 O&M Staff Organization
- 7.2 Routine and Preventative Maintenance
- 7.3 Asset Management and Condition Rating
- 7.4 Small Scale Repair Projects
- 7.5 Emergency Response and Mutual Aid
- 7.6 Training and Certifications

Chapter 8 - Long Term Challenges

- 8.1 Existing Infrastructure
- 8.2 Onsite Sewage Systems
- 8.3 Extending Sewers to New Development
- 8.4 Sea Level Rise
- 8.5 Use of Drinking Water Resources
- 8.6 Use of Energy Resources
- 8.7 LOTT/City Coordination
- 8.8 Equitable and Predictable Rates and Fees
- 8.9 Public Education and Involvement

Chapter 9 - Goals, Objectives and Strategies - Implementing the Plan

- 9.1 Water Quality
- 9.2 Public Health
- 9.3 Water Use
- 9.4 Energy
- 9.5 Utility Rates and Fees
- 9.6 Integrated Water Resources
- 9.7 Information
- 9.8 Summary Table of Strategies

Chapter 10 - Development of the Capital Facilities Plan

- 10.1 Physical Condition of the Gravity Sewer Collection System
- 10.2 Capacity Analysis of the Gravity Sewer Collection System
- 10.3 Condition Assessment of Lift Stations and Force Mains
- 10.4 Capacity Analysis of the Lift Stations and Force Mains
- 10.5 Condition Assessment of the STEP Systems
- 10.6 Major Sewer Extensions
- 10.7 Summary

Chapter 11 - Paying for the Plan

- 11.1 Revenue and Expenses
- 11.2 Assets and Liabilities
- 11.3 Rates and Rate Structure
- 11.4 Financial Policies
- 11.5 Paying for the Plan
- 11.6 Comparison of LOTT and Olympia's Cost Centers

Appendices

A - WAC 173-240-050, Department of Ecology Requirements for Municipal Wastewater Plans, and Location in Current Plan

B - Fact Sheet

- C - Glossary of Terms and Acronyms
- D - List of External Links and References
- E - History of Olympia's Sewer System
- F - Outline and Accomplishments of the 2007 Wastewater Management Plan
- G - Lift Station Inventory
- H - Sewer Overflow Emergency Response Plan
- I - 2011-2016 LOTT Waste Discharge and Reclaimed Water NPDES Permit
- J - Water Resources and Wastewater Organization Chart
- K - Financial Analysis
- L - SEPA Checklist and Determination
- M - Maps
 - 1. Sewer Service Area, showing all Wastewater & Lift Station Basins, Sewer Trunk Lines
 - 2. Individual Watershed Basin maps, showing sewer infrastructure and OSS
 - 3. Geography and Topography of the Sewer Service Area, including some Water System infrastructure
 - 4. Thurston County Urban Area Onsite Septic System Analysis Maps
- N - 2011 LOTT I&I and Flow Monitoring Report
- O - Wastewater Existing Policies and Procedures:
 - 1. Grinder Pump Policy (Sept. 2006) and Maintenance Agreement template (2011)
 - 2. Grease Interceptors/Traps, June 2008
 - 3. To and Through Requirement (2012)
 - 4. Process for Review and Approval of Septic Systems in City's Sewer Service Area, July 2008
 - 5. OSS Permitting Flowchart, September 2012
 - 6. Sewer Service Line Sinkhole SOP, January 2012
 - 7. Intruding Taps SOP, April 2012
- P - Agreements: (Links will be provided for online version of final Plan only)
 - 1. 2013 Lacey Agreement (in draft form as of March 2013)
 - 2. 2012 Mutual Aid Agreement
 - 3. 2007 Overhulse Lift Station Agreement
 - 4. 2007 South Puget Sound Community College Lift Station Interlocal Agreement
 - 5. 2006 Providence St. Peter Lift Station Agreement
 - 6. 1999 Interlocal Cooperation Agreement for Wastewater Management by the LOTT Wastewater Alliance
 - 7. 1992 Implementing Agreement between Olympia, Lacey, Tumwater and Thurston County
 - 8. 1992 General Sewerage Agreement for the Unincorporated Urban Growth Management Area
 - 9. 1980 Agreement and Contract for Motel 8 Area in Lacey
 - 10. 1950 Tumwater Agreement



1.1 Overall Vision

The Wastewater Utility's mission is to collect and convey wastewater to treatment facilities in a manner that protects the health of both the public and our environment. We do this by: (1) maintaining and replacing our existing utility infrastructure, and (2) planning for expansion into areas within the City and its Urban Growth Area (UGA) that are currently undeveloped or served by onsite sewage systems.

Under the direction of the 2007 Wastewater Management Plan, Utility staff is successfully implementing a comprehensive and effective wastewater program. This Plan provides refinements rather than major changes to the 2007 Plan.

The guiding vision for how we address these two aspects of Wastewater Management is in the Utilities Goals in the City's Comprehensive Plan. For example, Goal GU2 in the 2013 draft update to the Utilities chapter reflects the City's vision for a sustainable future for our community:

Reliable service is provided at the lowest reasonable cost, consistent with the City's aims of environmental stewardship, social equity, economic development and the protection of public health.

With this Wastewater Management Plan, our intention is to identify goals and objectives and develop specific strategies to address them. The Plan will serve as our guide to implementation over the next 20+ years. We are following an overall strategy of watershed-based management, as a framework for integrating the management of all the water resources and related infrastructure in our community.

The Wastewater Utility provides a level of service consistent with City and State expectations for protecting public and environmental health as well as ensuring that infrastructure operation, maintenance, and upgrades are proactively completed. Under this Plan, the expected level of service will be maintained.

The Utility is responsible for conveying wastewater flows to the LOTT Clean Water Alliance treatment facilities. While well-coordinated with Utility management and this Plan, the LOTT Alliance is a distinct entity meeting the needs of Olympia, Lacey, Tumwater and Thurston County. More information on LOTT can be found at <http://www.lottcleanwater.org/>.

This chapter summarizes the Challenges identified in this Plan; presents the Goals, Objectives and Strategies we've developed to address these Challenges; and lists the capital projects we've prioritized for implementation in the next 20+ years. Table 1.1 defines these key planning terms; understanding them will make it easier to see how specific elements of this Plan relate to each other.

Table 1.1
Key Planning Terms

Goals	Broad, qualitative statements of what the Wastewater Utility hopes to achieve.
Objectives	Specific, measurable statements of what will be done to achieve the Goals within a particular time frame.
Strategies	General approaches or methods for achieving Objectives and resolving specific issues. Strategies speak to the question "How will we go about accomplishing our Objectives?"
Alternatives	Specific infrastructure investments or operational changes within a Strategy aimed at achieving the Objectives.
Criteria	Measures or considerations used to evaluate alternatives or determine success in achieving an objective, e.g., when ranking the need for lift station upgrades in a vulnerability assessment.
Definitions are adapted from EPA's <i>Planning for Sustainability, A Handbook for Water And Wastewater Utilities</i> , EPA-832-R-12-001, February 2012. For other terms frequently used in this Plan, refer to Appendix C, Glossary of Terms and Acronyms.	

1.2 Challenges

We face numerous challenges in providing wastewater utility service in accord with our mission and vision. The 2007 Wastewater Management Plan identified four key challenges: (1) limiting new onsite sewage systems, (2) converting existing onsite systems to the City's sewer system, (3) prioritizing/funding sewer extensions into unsewered areas, and (4) maintaining and upgrading existing infrastructure. Since 2007, we have taken major steps to address these challenges; however, these and others remain to be addressed in this and future Wastewater Utility plans.

Below is summary of the major challenges now facing the Wastewater Utility; they are discussed in more detail in Chapter 8:

1. **Existing infrastructure** - Aging and maintenance-intensive infrastructure poses risks to public health and water quality. Effective operations and maintenance is critical to the wastewater system.
2. **Onsite sewage systems** - Large numbers of onsite sewage systems (OSS) in urban areas threaten water quality and public health, particularly in northeast and southeast Olympia.

3. **Extending sewers to new development** - Planned development in Olympia and its Urban Growth Area requires planning for and financing sewer extensions cost-effectively and equitably.
4. **Sea level rise** - Sea level rise poses long-term risk to downtown; early adaptation may allow for continued reliability and lowest reasonable cost.
5. **Use of drinking water resources** - Water, particularly drinking water, is a valuable resource that should be conserved, not wasted.
6. **Use of energy resources** - Conserving energy can help reduce carbon emissions and operational costs.
7. **LOTT/City Coordination** -The City and LOTT, including the other LOTT Partners, need to coordinate activities to minimize inefficiencies and duplication.
8. **Equitable and predictable rates and fees** - Creating predictability for customers and developers is difficult in a complex environment.
9. **Public education and involvement** - Keeping customers and the community involved and informed about challenges, needs, plans and proposals can help ensure that programs and projects are responsive to customer needs and community values.

1.3 Summary of Goals, Objectives and Strategies

In this Plan we establish seven Goals for the next 20 years, with one or more Objectives and Strategies for each. In Chapter 9 we show how they respond to the Challenges listed above, and how they are oriented toward the Comprehensive Plan vision of providing “reliable service at the lowest reasonable cost, consistent with the City’s aims of environmental stewardship, social equity, economic development and the protection of public health”.

The following is a summary list of our Goals, with each one’s corresponding Objective(s). Under each Objective are its respective Strategies.

Water Quality Goal – Clean Water Act and Safe Drinking Water Act standards are met.

Objective 1A – Identify and eliminate at least two illicit discharges of wastewater into stormwater conveyance pipes and receiving waters each year.

Strategy – Detect and eliminate illicit discharges.

Objective 1B – Manage existing and potential new OSS so there is no net annual increase in the total number of OSS in Olympia’s sewer service area.

Strategy – Accommodate the limited use of new OSS systems.

Objective 1C – Encourage OSS conversions through the Septic to Sewer Program.

Strategy – Fund limited sewer extensions for OSS conversions.

Strategy – Start GFC payment plan for OSS conversions.

Strategy – Provide OSS technical assistance.

Objective 1D – Facilitate the orderly expansion of the public sewer system.

Strategy – Support alternative sewer technologies.

Strategy – Allow new STEP systems for OSS conversions and infill.

Strategy – Start a green infrastructure project evaluation process.

Public Health Goal – No one is exposed to sewer overflows or excessive odors.

Objective 2A – Reduce the number of sewer pipe blockages and the volume of sewer overflows annually.

Strategy – Continue preventive pipe maintenance program.

Strategy – Continue mapping and documentation program.

Strategy – Expand FOG education and management program.

Strategy – Partner with LOTT to reduce infiltration and inflow.

Strategy – Separate combined sewers.

Strategy – Use LOTT Mutual Aid Agreement during emergencies.

Strategy – Reduce the introduction of solid wastes into sewer.

Strategy – Encourage use of new maintenance technologies.

Objective 2B – Reduce odors from public sewer systems to acceptable levels.

Strategy – Address odor issues in a timely manner.

Objective 2C – Use computer-based asset management systems in order to achieve low infrastructure life-cycle costs at a consistent level of service.

Strategy – Continue the PACP pipe condition rating program.

Strategy – Initiate the MACP manhole condition rating program.

Strategy – Continue priority pipe repair program.

Strategy – Continue lift station maintenance and repair.

Water Use Goal –Potable water use and greywater flows in the sewer collection system are minimized.

Objective 3A – In partnership with the Drinking Water Utility, reduce non-irrigation residential water use.

Strategy – Implement a volume-based residential rate structure.

Strategy – Coordinate education efforts with the Water Utility.

Strategy – Partner with Thurston Co. to allow and encourage greywater irrigation.

Energy Goal – The Utility is more energy efficient, and uses cleaner energy sources.

Objective 4A – Reduce the Wastewater Utility's energy use by 5% within six years of adopting this Plan.

Strategy – Complete an energy audit for all lift stations.

Strategy – Increase frequency of force main cleaning.

Strategy – Minimize new lift stations.

Objective 4B – Reduce diesel emergency generator emissions by replacing the two oldest generators in the system within six years of adopting this Plan.

Strategy – Pursue funding of clean fuel retrofits for generators.

Rates and Fees Goal – Utility rates and fees are equitable and affordable, minimizing rate increases while maintaining consistent levels of service.

Objective 5A – Coordinate the financial management of the three water-based utilities so that utility rate increases are evenly distributed to customers.

Strategy – Coordinate regular rate studies with the City’s other water-based utilities and LOTT.

Objective 5B – Manage utility rates and connection fees consistent with the City’s guiding principle of growth paying for growth.

Strategy – Maintain equitable rates and GFCs.

Integrated Water Resources Goal – Water resource utilities are planning together for long-term environmental, economic and social changes.

Objective 6A – Integrate Water Resource activities that share common goals, resources and/or assets.

Strategy – Enhance watershed-based planning.

Strategy – Plan for the anticipated impacts of sea level rise.

Information Goal – Customers and community are informed about and involved in wastewater management activities.

Objective 7A – Provide adequate staff and resources to keep customers and community informed and involved.

Strategy – Maintain adequate staffing for customer service.

Strategy – Update and expand the Utility’s web presence.

Strategy – Coordinate customer service and education with the City’s other water-based utilities and LOTT.

1.4 Summary of Capital Projects

Table 1.2 lists all of Capital Projects identified in Chapter 10 that are scheduled to be constructed in the next six years. For a complete list of projects for the 20-year planning period, see Chapter 10.

Table 1.2
Six Year List of Capital Projects

Project Name	Description	Cost (\$K)	Timing
Program 9021 – Asphalt Overlays			
Asphalt Overlay	Adjust manhole rims et.al. in Street ROW	\$10	Annual
Program 9703 – Replacements and Repairs			
Prioritized Repairs	Major repairs using trenchless technologies	\$265	Annual
Spot Repairs	Isolated open cut repair work	\$100	Annual
Manhole Repair and Replacement	Addressing structural deficiencies and leaks	\$100	Every 3 years
Commercial STEP Conversion on Yelm Highway	Converting existing commercial STEPs to gravity connection to the sewer on Yelm	\$420	2016
Pipe Corrosion Abatement	Hydrogen sulfide reduction system and man-hole repairs in SE neighborhood	\$150	2014
Pipe Corrosion Abatement	Hydrogen sulfide reduction system and man-hole repairs in NE neighborhood	\$150	2016
Program 9806 – Lift Stations			
Black Lake Upgrade	New lift station package	\$900	2014
Water Street Generator	Replace existing diesel generator	\$150	2015
28 th Ave. LS Property Purchase	Purchase property for future LS in NW	\$100	2015
Miller and Central Upgrade	Replace existing wet well and pumps	\$750	2016
Miller and Ann Generator	Install diesel generator	\$60	2017
Water St LS Force Mains Upgrade	Replace 18 and 30-inch force mains	\$900	2018
Old Port 2 Upgrade	Increase capacity	\$600	2019
Program 9808 – Sewer System Planning			
Televising and Condition Rating	Miscellaneous projects(s)	\$21	Annual
Program 9809 – Sewer System Extensions			
Boulevard Sewer Extension	Extension of sewer main south on Boulevard	\$750	2017
Program 9810 – Pipe Capacity Upgrades			
None	None anticipated in 6-year near term		
Program 9813 – Onsite Sewage System Conversions			
Annual Sewer Extensions	Short sewer main extensions	\$150	Annual
Neighborhood Sewer Program	Larger project to convert OSS to sewer	\$500	Every 3 years
Program 9903 – Infrastructure Pre-Design			
Pre-Design	Miscellaneous annual project(s)	\$37	Annual
	Total 6-year Capital Facility Plan	\$9,293,000	
	Average Annual CFP	\$1,550,000	



Background Information

Chapter 2

In this chapter we provide basic planning and physical environment information as context for discussion in the following chapters. We use community trends in land use, population and demand for sewer service as the basis for projecting wastewater flows and future wastewater infrastructure and program needs. The physical landscape dictates to a certain extent the types of sewer collection and conveyance systems that are most appropriate for each basin within the Sewer Service Area.

This chapter also gives an overview of the state and federal regulatory environment associated with planning, constructing, operating and maintaining wastewater infrastructure; a brief discussion of other plans that relate to water-based resources in our community; and some of the agreements in place among the LOTT partners that relate to wastewater.

2.1 Sewer Service Area

The City of Olympia is located on Budd Inlet at the southern end of Puget Sound. The Wastewater Utility's Sewer Service Area (see Figure 2.1) includes the 17.5 square miles of the City, its Urban Growth Area (UGA) (approximately eight square miles in unincorporated Thurston County), several areas in the Cities of Tumwater and Lacey for which service agreements have been executed, and a small area outside its western UGA which received sewer service before the City's UGA boundaries were established under the Growth Management Act. Appendix M includes a larger scale map showing the Sewer Service Area.

Many neighborhoods and individual lots within the City and its UGA, including unincorporated "islands" within the external boundaries of the City, are still using onsite sewage systems (OSS). See Chapter 4 for a discussion of OSS, and current City and Thurston County policies regarding them.

The Sewer Service Area is divided into six major watersheds, or basins, also shown in Figure 2.1, to facilitate watershed-based planning strategies. Chapter 5 discusses each basin in more detail, including the characteristics and challenges associated with each of them.

Figure 2.1

Wastewater Utility Service Area and Watershed Basins

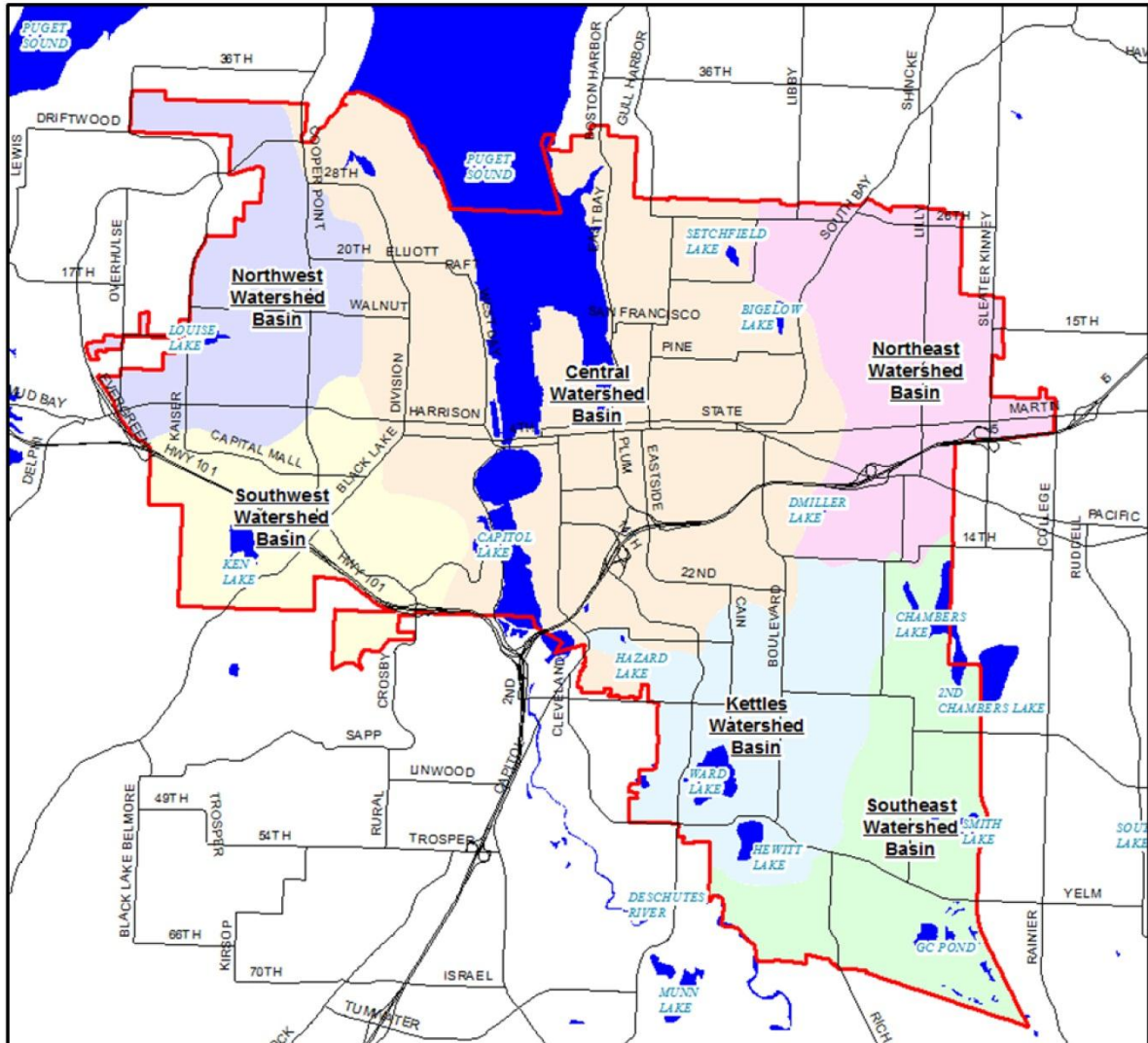

2.2 Population and Land Use

Population and Demand for Sewer Service

Population data in this Plan is based on data published by the Thurston Regional Planning Council (TRPC) and electronic source data obtained from the TRPC. Historic population trends for the City of Olympia are shown in Table 2.1. Table 2.2 and Figure 2.2 show population forecasts. Given current wastewater policies and regulations, the vast majority of new population in Olympia will be served by municipal sewer service.

Table 2.1
Olympia and UGA Historic Population Trends*

	1995	2000	2005	2010
City	37,734	42,514	43,330	46,513
UGA	8,670	9,269	10,980	11,797
Total	46,404	51,783	54,310	58,310

*Source: Thurston Regional Planning Council

Figure 2.2
Population Projections

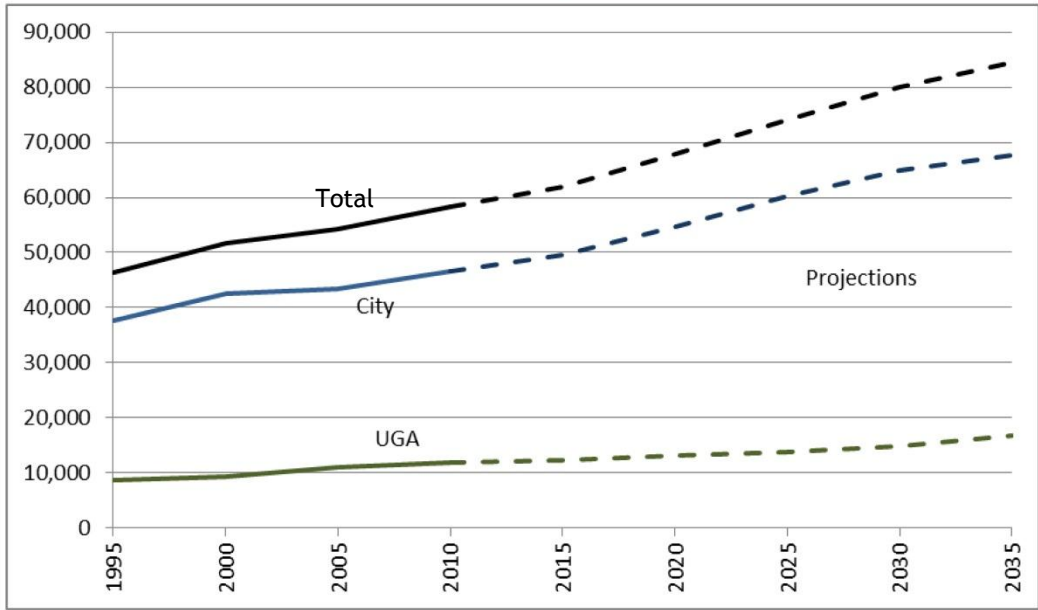

Table 2.2
Olympia and UGA Population Forecast

	2015	2020	2025	2030	2035
City	49,550	54,609	60,133	64,983	67,725
UGA	12,273	13,237	13,896	14,962	16,671
Total	61,823	67,846	74,029	79,945	84,396

Land Use Trends

From 2004 to 2007, residential and commercial properties developed rapidly in Olympia, its UGA, and the adjacent cities of Lacey and Tumwater. During this period, Olympia permitted relatively large subdivisions at an increasing rate, with approximately 300-500 homes constructed per year. Urban villages and other planned unit developments were constructed. Southeast Olympia and the adjacent UGA experienced the greatest development pressure. Areas of northwest Olympia and, to a lesser extent, northeast Olympia also developed rapidly.

While overall construction activity in Olympia and its UGA leveled off and remained relatively steady from 2007 to 2011, especially compared to its municipal neighbors, Lacey and Tumwater, residential housing construction dropped dramatically for all three cities. In Olympia, near term growth projections indicate slow but steady growth in residential construction. In 2011, 75% percent of new home construction was single family residential and 22% multifamily.

Projected Growth Patterns

While there are no clear trends as to growth in one particular area of the City, Thurston County Regional Planning Council data on housing starts and population indicate that growth in the near term (one to six years) will continue to be focused in urban areas, rather than rural areas of Thurston County. Also, while most new housing starts will continue to be single family residential, there will be an increase in the density of housing and numbers of multifamily housing units constructed.

2.3 Wastewater Flows

Demand for sewer service is calculated using a value called an “Equivalent Residential Unit” (ERU). ERUs create a common base for estimating the amount of wastewater generated from both residential and commercial sources. Olympia uses data provided by its Utility Billing section and the LOTT Clean Water Alliance to calculate the number of ERUs served and the average winter wastewater flow per single family residence. These calculations generate an average winter wastewater flow of about 130 gallons per day per single family residence.

ERUs are used to plan infrastructure needs and define billing rates. Combining these typical wastewater flows with projections of future connections allows us to evaluate system capacities and needs. Projected growth data provided by the Thurston Regional Planning Council (TRPC) is used to compute the projections of future ERUs in Table 2.3.

Table 2.3

ERUs for Olympia's Sewer Service Area¹

	2010	2015	2020	2025	2030	2035
Single Family ERU's	12,919	13,697	15,032	16,402	17,712	18,698
Multi-Family ERU's	5,541	5,875	6,447	7,035	7,597	8,020
Commercial ERU's	6,086	6,453	7,081	7,727	8,344	8,809
Total ERU's	24,546	26,025	28,560	31,164	33,653	35,537
% Increase	N/A	6%	9.7%	9.1%	8%	5.6%

¹Based on growth projections from TRPC, and data from LOTT and the City's Utility Billing

Table 2.4, summarizing recent historical flows, indicates that wastewater generation has been decreasing since 2007. Reduced wastewater generation even as Olympia’s population grows reflects the effectiveness of community water conservation practices. For more information regarding basin-specific flows, including wet weather flows, see LOTT’s most recent Annual Capacity Report.

Table 2.4
Olympia Wastewater Flows (MGD)¹

	2006	2007	2008	2009	2010
Average Daily Base Wastewater Flow, MGD	4.31	4.32	4.02	3.42	3.56
Average Peak Hour Flow, estimated MGD ²	26.6	26.8	24.9	21.2	22.1

¹Source: LOTT 2010 Annual Capacity Reports.

²Based on LOTT’s calculation for Olympia of 6.2 as the average ratio of Peak Hour Flow to Base Flow.

2.4 Physical Setting

Water Resource Inventory Area

The City’s entire Sewer Service Area is within Water Resource Inventory (WRIA) Area 13 - Deschutes. This includes the portions of the Sewer Service Area within the Eld Inlet and Henderson Inlet watersheds on the west and east sides of Olympia. Washington Department of Ecology’s initial intent for the WRIAs was to complete drainage basin-specific assessments in order to better understand the relationships between climate, surface water and groundwater in a given area. Elements of the initial assessment, completed in 1995, and the extensive documentation and ongoing research that has followed, include water withdrawals and allocations, hydrology, water quality, and riparian values such as fisheries habitat.

Past and ongoing efforts related to water, water quality and habitat in WRIA 13 include, but are not limited to, establishing seasonal instream flow requirements for the Deschutes River, and characterizing water quality degradation and how to limit or reduce it. Water quality issues and constituents of interest include temperature, pH, fine sediment, dissolved oxygen, fecal coliforms, and nutrients such as nitrogen and phosphorus. These have had an adverse effect on the health of the lower reaches of the Deschutes, as well as most of the urban watersheds within the Cities of Lacey, Olympia and Tumwater.

As a result, the Department of Ecology, with stakeholder input, is in the process of establishing Total Maximum Daily Loads (TMDLs) for some of these constituents, under a process established by Section 303(d) of the federal Clean Water Act. This process has a direct relationship to the issues of onsite sewage system management (see Chapter 4), discharge of treated effluent into Budd Inlet, and potentially groundwater recharge of treated water (see the LOTT Clean Water Alliance discussion in Section 3.6).

In addition, the Henderson Inlet Watershed Management Area has been established to address ground and surface water issues that have impacted shellfish and other species. See Chapter 4 for further information

Geology and Soils

Geology in Olympia and the rest of Thurston County is the result of glacial activity in Puget Sound. Receding glaciers left the land dotted with lakes, ponds and materials called glacial till or glacial drift, deposited during successive glacial periods. This material varies from fine particles to large rocks and is generally permeable, with the capacity to absorb the 50-plus inches of annual precipitation.

However, soil characteristics present challenges for both gravity sewers and onsite sewage systems. The 1990 Soil Survey of Thurston County Washington identified 30 types of soil within the urbanized Thurston County UGA (U.S. Department of Agriculture Soil Conservation Service, 1990). Only about one percent of the county land area has soils that meet all criteria for ideal functioning of onsite sewage systems (Sandison, 1996). Soils in most of Olympia's UGA are either too porous, too close to groundwater, or too close to underlying impermeable layers to allow ideal onsite treatment of wastewater. During winter months, many soils are occasionally or consistently saturated.

Construction of gravity sanitary sewer systems is influenced by soil texture, depth to the water table, and linear extensibility (shrink-swell potential), which can influence soil stability. Depth to the seasonal high water table, flooding and ponding may restrict the period when excavation can be done, and slopes create more difficulty when using machinery. The areas with unfavorable soil conditions may limit installation of deep sewers without major soil reclamation, special design or expensive installation procedures. Poor performance and high maintenance can be expected.

In some portions of the City's Sewer Service Area, especially west and southwest of Ken Lake, there is very little soil on top of the impermeable basalt layer. Soils there are inappropriate for onsite sewage systems and installation of gravity sewers is difficult.

See Chapter 4 for more information on soils and groundwater, and their impacts on onsite sewage systems.

Topography

Thurston County's topography is characterized by coastal lowlands and wooded prairies up to the Cascade foothills. In general, Olympia's topography slopes to downtown, where the LOTT Clean Water Alliance's main treatment facility (Budd Inlet Treatment Plant) is located. Land elevation within and between neighborhoods varies appreciably, often creating topographic barriers for the gravity conveyance of wastewater to the LOTT facility. To overcome these barriers, the Wastewater Utility operates 33 sewer lift stations and over 1,860 STEP systems that pump effluent from individual residences to a centralized collection system and ultimately to the LOTT facility. A number of privately-owned and operated grinder pumps provide a pressurized service connection to the City's sewer collection system.

Climate

Winter weather in Olympia is temperate, wet and generally overcast. Summer weather is moderate and comparatively dry. The average annual range in temperature is relatively narrow, from an average low of 40 degrees (Fahrenheit) to an average high of 60 degrees. Monthly average low and high temperatures vary from 32-50 degrees and 44-77 degrees, respectively.

The average annual precipitation for Olympia is 51 inches. During the wet season, generally from October to May, storms usually arrive from the southwest and continue north into the Puget Sound area. Most precipitation occurs during November, December and January (averaging 8.2, 7.9 and 7.6 inches per month, respectively), with an occasional Arctic storm that brings freezing temperatures, hail or sleet, freezing rain or snow.

Water Supply

Olympia depends on springs/groundwater for its drinking water supply. About 70 percent of Olympia's water comes from McAllister Springs, located about 10 miles east of the city. Water leaves McAllister Springs through a 36-inch transmission main and is pumped to the Meridian Storage Tanks less than a mile west of the Springs. The water then flows by gravity from the storage tanks through the transmission main for an eight-mile journey to the storage tanks on Fir Street and 7th Avenue. From these storage tanks, the water is pumped and piped throughout the city.

The City also has five water supply wells. Three are on the west side of Olympia: two at Allison Springs and one on Kaiser Road. Two wells are in southeast Olympia: one on Hoffman Road and one at Shana Park, near the Indian Summer Golf Course.

As part of its long range planning for additional water supply and redundancy within the system, Olympia is developing the McAllister Wellfield (which recently received a water right from the Washington State Department of Ecology) and is planning to use an existing well at Indian Summer Golf Course, pending approval of a request to transfer water rights (City of Olympia, 2004). See the City's 2009 Water System Plan for more information.

Some Wastewater Utility customers have their own water wells and therefore do not receive City water.

2.5 State and Federal Regulations

Wastewater Utility services are planned and implemented within a complex framework of statutes, regulations, plans and policies adopted by federal, State, County and City governments and intergovernmental agreements with neighboring jurisdictions. Below are brief discussions of the more important programs and regulations. Please click on the appropriate link for more information.

Clean Water Act and Department of Ecology

The federal Clean Water Act, 33 U.S.C. §1251 et seq. (1972), forms the basis of our regulatory standards regarding discharges of pollutants into surface waters. Additionally, the Safe Drinking Water Act, 42 U.S.C. §300f et seq. (1974), protects and regulates all potential sources of drinking water, both surface and groundwater.

The United States Environmental Protection Agency (EPA) is responsible for enforcing the provisions of both the Clean Water Act and Safe Drinking Water Act, through programs such as the National Pollutant Discharge Elimination System permit program, authority for which has been delegated to the Department of Ecology (Ecology) in Washington State. LOTT's Budd Inlet Treatment Plant holds the current NPDES permit that covers the City's wastewater collection system (see Appendix J). EPA has also delegated authority to Ecology for approval of wastewater plans and specifications. Washington Administrative Code (WAC) 173-240-050, Department of Ecology Requirements for General Sewer Plans, lists specific information that wastewater plans should address when submitting one to Ecology for approval (see Appendix A).

Under RCW 90.48.110(2), Ecology has delegated to the City of Olympia responsibility for review and approval of engineering reports, plans and specifications for new wastewater facilities within its Sewer Service Area. Engineering specifications for the use and construction of sewer infrastructure are provided in Ecology's Criteria for Sewage Works Design.

Ecology has also authorized the City of Olympia to issue permits for discharge into the wastewater system (WAC 173-208). These are regulated under the Industrial Pretreatment Program jointly administered by LOTT under its NPDES permit and the City through OMC 13.20.

Growth Management Act

The City of Olympia is required by the Growth Management Act (RCW 90.48) to plan for 20 years of future growth. State-mandated growth management planning is designed to produce denser urban areas while protecting the rural character of unincorporated areas. Consistent with the GMA, the Wastewater Utility manages its infrastructure capacity to accommodate projected development within the City and its Urban Growth Area (UGA). Sewer extensions outside the UGA are normally not allowed under the GMA without a rigorous demonstration of a need to address an urgent public health threat.

SEPA

SEPA, the State Environmental Policy Act (RCW 43.21C), requires the City to consider the potential environmental impacts of a proposal. Plans such as this one are considered non-project, or program, proposals and do not go through as rigorous an environmental review as do specific project proposals.

As a lead agency under SEPA, the City identifies the potential impacts of sewer service associated with proposed new development and measures to mitigate these impacts. See Appendix O for the SEPA review and determination for this Wastewater Management Plan.

Washington Department of Health

The Washington State Department of Health is this state's regulatory authority for most issues related to drinking water. In addition, the Department of Health has authority for approving private sewage disposal systems (WAC 246-272), but has delegated the authority to approve all systems with a design flow of less than 3,500 gallons per day to the Thurston County Board of Health. Criteria for system approval include minimum lot size and setbacks from sources of drinking water or other water resources. See Chapter 4 for more information.

2.6 Local Regulations and Design Standards

Olympia Municipal Code

The Olympia Municipal Code (OMC) addresses wastewater issues in the following chapters and sections:

3.04.750	Sewer Capital Improvement Fund
3.20	Local Improvement Districts
4.24.010	Rates
13.08	Sewers
13.20	Wastewater System (Pretreatment)
17.44	Subdivisions - Improvements
18.04.080E	Developments which rely on onsite sewage systems

Other chapters of the OMC, for example those addressing Zoning and Building Codes in Chapters 16 and 18, also include regulations that directly or indirectly address issues related to providing sewer service.

Olympia Engineering Design and Development Standards

The City of Olympia’s design and development standards regarding wastewater infrastructure are contained in Chapter 7 of the Engineering Design and Development Standards (EDDS). The EDDS are updated every few years, at which time they address inconsistencies in language, new industry standards, input from local businesses and related professionals, and comments from local and state jurisdictions, private citizens and other stakeholders.

WAC 173-240, Submission of Plans and Reports for Construction of Wastewater Facilities, includes in subsection .040, Review Standards, a requirement that plans and reports be “reasonably consistent” with the Department of Ecology’s “Criteria for Sewage Works Design” manual. The City’s EDDS fulfills this requirement.

Article IV of the Sanitary Code for Thurston County

Article IV of the Sanitary Code for Thurston County includes “rules and regulation of the Thurston County Board of Health governing treatment and dispersal of sewage.” Article IV protects public health through regulating the “location, design, installation, operation, maintenance, and monitoring of OSS...” through the authority granted in Chapter 70.05 RCW and 246-272A WAC. See Chapter 4 of this Plan for more information.

2.7 Related Plans

Following are a number of plans and guidance documents that relate directly or indirectly to the 2013 Wastewater Management Plan.

Olympia Comprehensive Plan

In addition to its sustainable community vision, the Comprehensive Plan makes commitments to the future through its goals and policies. Specific Wastewater Utility activities are guided by Comprehensive Plan goals and policies established in the Growth Management, Environment, Public Utilities and Services, and Public Education sections of the Comprehensive Plan.

Olympia Capital Facilities Plan

The City's Capital Facilities Plan (CFP) is updated every year to reflect six and 20-year priorities for public infrastructure construction. Wastewater projects identified and prioritized by this Plan (see Chapter 10) are more fully defined, funded and implemented through the City's Capital Facilities Planning and yearly budgeting processes.

Thurston County Sewerage General Plan

The 1990 Thurston County Sewerage General Plan for Unincorporated Urban Growth Management Area promotes the orderly growth of the urban area, addresses the ownership of sewers, timing of construction, and hookup and payment policies for the unincorporated Urban Growth Area (UGA).

This plan requires that areas within the short-term UGA (defined in the document) be developed on sewers or community onsite sewage systems, and specifies that areas within the long-term UGA (also defined in the document) need not be served by sewers at the time of construction. Since 1990, the short-and long-term UGAs have been combined into one UGA which, despite having somewhat different boundaries than those originally developed by 1990, is regulated under the previous policies for the short-term growth area. Under this approach, community onsite sewage systems are allowed in the UGA. In the long-term, sewer service is to be provided. Areas served by sewer and community systems are required to annex or sign a no-protest annexation agreement. The plan also defines circumstances under which sewer service can be extended to areas outside the UGA.

While the delineation between long-term and short-term urban growth areas is no longer in effect, the Thurston County General Sewerage Plan continues to guide some of the sewer policies relevant to development in the UGA, particularly when a development plan may include using a community onsite sewage system. Also see the 1992 General Sewerage Agreement for the Unincorporated Urban Growth Management Area.

Olympia 2009 Water System Plan

The City of Olympia delivers high quality drinking water to nearly 55,000 people through approximately 19,000 service connections. The 2009 Water System Plan presents both a 50-year vision and a six-year plan for efficiently using regional water resources to ensure safe and sustainable drinking water for the City's growing needs.

The plan is used by City staff to accomplish goals around efficient use and protection of current water supplies to ensure future supplies, maintain a reliable water system infrastructure, and manage the Drinking Water Utility in a fiscally responsible manner. The Plan also highlights past accomplishments and current priorities.

Issues covered in the 2009 Water System Plan include actions to protect groundwater quality and promote water conservation, and an increased emphasis on utilizing reclaimed water.

Reclaimed water, addressed in Chapter 7 of the 2009 Water System Plan, is part of the Drinking Water Utility's water conservation strategy to ensure regional water supplies are used efficiently. After the LOTT Budd Inlet Treatment Plant generates reclaimed water to Class A standards, the City purveys it to four Olympia customers, primarily for irrigation. The LOTT Clean Water Alliance is also actively pursuing groundwater infiltration of reclaimed water outside City limits. The City's Reclaimed Water Program, begun around 2005, is implemented through Olympia Municipal Code (OMC) 13.24, state and City standards, and individual End User Service Agreements. Reclaimed water staff is also guided by a reclaimed water system expansion plan and procedures manual.

The Washington State Department of Health (DOH) requires the City to update its water system plan every six years. DOH must approve the plan for the City to be in compliance with water system planning requirements. The next update is scheduled for spring 2014.

1996 North Thurston County Coordinated Water System Plan

Thurston County oversees a planning process that coordinates and regulates water system services within the urban area of North Thurston County and designates Urban Water Supply Services Areas. Policies and recommendations contained in this 1996 document are intended to "encourage the effective coordination and development of water systems capable of meeting domestic and fire protection water requirements of the property owners and residents of the North Thurston urban area."

Olympia 2003 Storm & Surface Water Plan

The role of the City's Storm and Surface Water Utility was bolstered in 1990 with the following mission:

To provide services that minimize flooding, maintain or improve water quality, and protect or enhance aquatic habitat. These services reflect community values, are efficient and cost-effective, and satisfy regulatory requirements and Olympia Comprehensive Plan goals and policies.

The 2003 Storm & Surface Water Plan and its 2010 refinements to goals and priorities guide the Utility's action in regards to flooding, water quality and aquatic habitat management. Its illicit discharge detection and elimination (IDDE) program includes identifying sources of wastewater connected to the stormwater conveyance and discharge system, and eliminating them in coordination with the Wastewater Utility.

Sustainable Thurston

Currently being developed by the Thurston Regional Planning Council, Sustainable Thurston is intended to “create a vision for how the Thurston Region will look, function and feel over the next 20 - 30 years.” By the end of 2013, it intends to have a Regional Plan for Sustainable Development, a Regional Housing Plan, and a Sustainable Economy Strategy.

While Sustainable Thurston is not a regulatory or state-mandated planning effort, its current effort explores many issues including the community’s water resources. The effort includes identifying challenges and opportunities related to water quality and onsite sewage systems, as well as sewer collection, treatment and disposal. Information being developed as part of this process is aiding implementation of several Wastewater Utility goals - for example, addressing basin-specific water quality issues, and sustainably expanding sewer service into areas within the City and its Urban Growth Area which are currently undeveloped or served by onsite sewage systems.

2.8 Governmental Agreements

A number of agreements are in place among the four local jurisdictions that make up the LOTT Clean Water Alliance. Below are brief summaries of some of the more important ones. See also Appendix Q for a more complete list of active agreements related to the Wastewater Utility.

1992 Agreement for the Implementation of the Thurston County Sewerage General Plan for the Unincorporated Urban Growth Management Area

This agreement serves as the means to implement the 1990 Thurston County Sewerage General Plan. It clarifies ownership and payment policies, procedures and responsibilities for sewers and community onsite systems. The agreement anticipated “eventual interception of individual and community onsite systems” within the Urban Growth Area (UGA) by gradually constructing regional pipe systems and connecting residences. Key provisions of the agreement are:

- Establishing that Olympia, Lacey and Tumwater are the primary providers of sewers and other utilities in their urban growth areas, with authority to establish policies and development standards applicable to the unincorporated County within their UGA.
- Procedures for the joint review and annexation of development projects within the UGA.
- Agreement by the three cities to own and operate community systems, including community onsite sewage systems and STEPS, within their service areas. This provision ensures consistent wastewater services to all customers as mandated by the Growth Management Act. The agreement establishes the requirements under which the cities will accept responsibility for community systems and will serve as the permit holder for these systems.

1999 Interlocal Cooperation Act Agreement for Wastewater Management

The Interlocal Cooperation Act Agreement for Wastewater Management by the LOTT Wastewater Alliance (now LOTT Clean Water Alliance) was executed on November 5, 1999 and adopted by ordinance January 24, 2000. This agreement provided for a new governance structure to carry

out the regional Wastewater Resource Management Plan and set the stage for consolidation of the ownership and management of all joint facilities under the management and control of a new LOTT organization. It superseded the 1976 agreement establishing the LOTT Partnership, under which ownership and operation of the joint facilities was handled by Olympia. The new facilities implemented pursuant to this agreement, together with those developed as joint facilities under the 1976 agreement, are operated for the benefit of all Partners.

Besides describing how LOTT is managed, the agreement addresses a number of issues, including flow reduction goals, pretreatment requirements, and allocation of costs.

Wastewater flows from the three local municipalities are piped to LOTT treatment facilities for treatment, re-use and /or discharge to receiving waters. All of Olympia's wastewater flows are treated by LOTT's Budd Inlet facility in downtown Olympia.

Biological nutrient removal (or advanced secondary treatment) which includes denitrification. Long-range planning for upgrades and expansions seeks to complete projects incrementally as needed by growing populations. LOTT is overseen by an elected-official Board and a technical support committee. At a staff level, projects and programs are well-coordinated with the local jurisdictions including Thurston County. More information on LOTT is provided in Chapter 3.

Intergovernmental Contract for Inflow and Infiltration Management and New Capacity Planning

This contract, executed in 1995 and updated in 1999, outlines a strategy for Olympia to first reduce, then limit, the amount of infiltration and inflow (I&I) entering the collection system, with financial participation from LOTT. I&I from groundwater and stormwater unnecessarily consume pipe and treatment plant capacity. The contract is included as Exhibit J of the 1999 Interlocal Cooperation Act Agreement establishing the LOTT Alliance described above.

Agreement Regarding Joint Wastewater Flow Reduction and Water Conservation

The Interlocal Cooperation Agreement between Thurston County and the Cities of Lacey, Olympia and Tumwater Regarding Joint Wastewater Flow Reduction and Water Conservation Projects was executed in October 2006 for the years 2007 to 2012, and extended through the year 2013 in December 2012. It defines the arrangements for joint management of flow reduction, especially water conservation projects at area schools. This agreement is included as Exhibit K of the 1999 Interlocal Cooperation Act Agreement establishing the LOTT Alliance described above.

Current Wastewater System

Chapter 3

Within the City and its Urban Growth Area, the Wastewater Utility is responsible for collecting wastewater from residences and businesses at the point where privately owned pipes enter the street system. Wastewater flows through City-owned and maintained sewer infrastructure to LOTT's Budd Inlet Treatment Plant, where it is treated and either discharged to Budd Inlet, or reclaimed for beneficial uses. City operations and maintenance staff ensure the safe conveyance of the wastewater flows from the City's extensive pipe and pumping systems to LOTT's infrastructure.

Figure 3.1 is a conceptual diagram showing the components of the City's sewer system.

Figure 3.1
Components of the Collection System

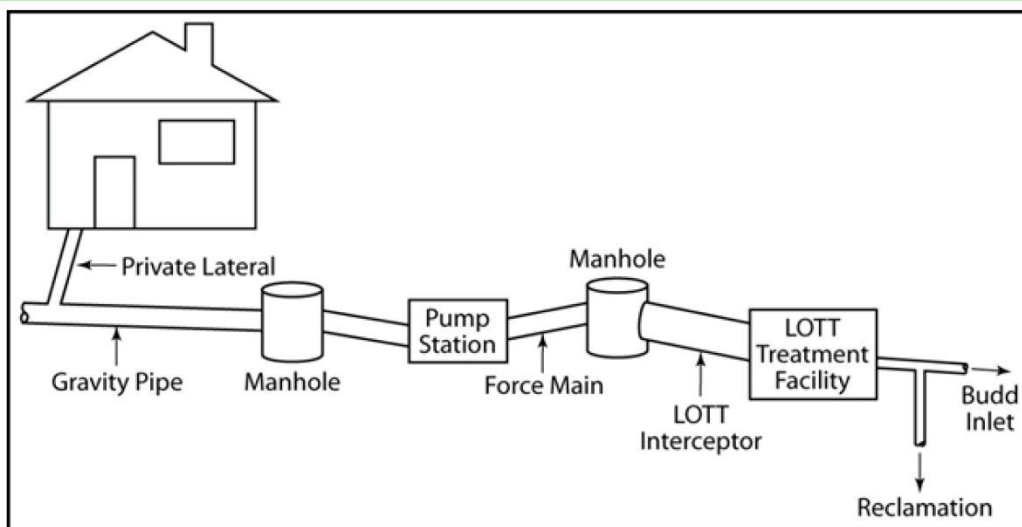

Gravity sewer pipes and regional pumps (lift stations) are the conventional way to convey wastewater from homes, businesses and other buildings to central treatment facilities. Wastewater flow in sewer mains generally follows the street system downhill. If needed it is pumped by a lift station over higher elevations in a force main and then continues flowing by gravity to one of several large LOTT transmission pipelines which convey it to the LOTT Budd Inlet Treatment Plant.

Olympia's wastewater collection system consists of approximately 185 miles of gravity sewer mains, 33 lift stations (including three privately-owned ones that the Utility operates and maintains under contract), and 8.5 miles of sewer force mains. It also includes approximately 1860 residential and commercial STEP (septic tank effluent pumping) systems and 140+ privately owned grinder pumps, which all pump sewage from an individual home or business into the collection system. Those pipes include approximately 29 miles of STEP pressure sewers and over one mile of grinder force main. Maintenance of these systems is a key responsibility of the Wastewater Utility.

There are also about 4,145 privately-owned and managed onsite sewage systems (OSS) in Olympia and its UGA. Thurston County and the City of Olympia jointly regulate the permitting and use of these systems. Property owners are responsible for maintaining these systems. See Chapters 4 more details about onsite systems.

The following sections describe in more detail each of the main components of the wastewater collection system:

- Gravity collection system
- Lift stations and force mains
- STEP systems
- Grinder pump systems

See Chapter 10 for an assessment of these components and an analysis of their capacity to handle current and projected wastewater flows.

3.1 Gravity Collection System

About 87% of our customers are served through a gravity sewer connection. Sewer pipes, usually buried beneath the center of streets, convey wastewater along typically straight runs of pipes between manholes. Manholes are located at junctions where the pipe changes direction and at intervals of 400 feet or less to allow access for inspection and maintenance. Cleanouts are often located at the upstream end of a pipe instead of a manhole if the sewer does not continue on.

Olympia's collection system includes about 185 miles of gravity sewer pipes, ranging from four to 42 inches in diameter, and approximately 4,000 manholes and over 1,000 cleanouts. The LOTT system has another 16 miles of gravity sewer interceptors in Olympia's sewer service area. Appendix M includes detailed mapping of the sewer system.

Table 3.1 summarizes the inventory of gravity collection pipes, showing diameter, length and materials. Most of the Utility's pipes are made of either concrete or Polyvinyl Chloride (PVC). Since the mid-1970s PVC piping has become the industry standard for sanitary sewers. PVC pipe is durable, easy to construct, resistant to corrosion and relatively inexpensive. Recently, high density polyethylene (HDPE) pipe has been promoted as a more environmentally-friendly alternative to PVC pipe because it uses a less toxic manufacturing process than PVC. In addition, many of the older sections of the collection system contain pipes made of vitrified clay (VC), concrete, asbestos cement (AC), cast iron (CI) and ductile iron (DI). The condition of these pipes varies with age and type of material.

Table 3.1
Gravity Sanitary Sewer Pipe Inventory (feet)

Pipe Diameter (inches)	Concrete	PVC	VC	AC	CI/DI	HDPE	Steel Trestle	Other or Unknown	TOTAL
4	302	30		482					814
6	38,086	7,335	16,870	1,000	274			267	63,832
8	248,566	386,213	48,906	8,202	6,178	3,800		317	702,182
10	31,357	12,739	12,331		701		215		57,343
12	33,634	22,065	4,319					159	60,177
14			654	1,681	36	1,111			3,482
15	21,321	16,103	9,276	109	134				46,943
18	19,286	11,294	2,039		991				33,610
20			606	623					1,229
21	1,606	241							1,847
22			584						584
24	4,637	151	465		123				5,376
30	3,384								3,384
36	1,726								1,726
42	884								884
unknown	290							592	882
Total lengths of each type of pipe, and their percentage of total system length									
Feet	405,079	456,171	96,050	12,097	8,437	4,911	215	1,336	984,296
Miles	76.7	86.4	18.2	2.3	1.6	< 1	< 1	< 1	185
Percentage	41%	46%	10%	1%	1%	< 1%	< 1%	< 1%	100%

3.2 Lift Stations and Force Mains

Olympia's rolling terrain requires the use of lift stations (also known as pump stations) to push wastewater over rises through force (pressurized) mains to the nearest gravity sewer that can carry flows further downstream without pumping. The City owns 30 lift stations and operates three others owned by Providence St. Peter Hospital, South Puget Sound Community College and the Cooper Glen Apartments in the Overhulse Drive area adjacent to The Evergreen State College campus. Table 3.2 shows information on the City-owned lift stations and their force mains. Dedicated operations and maintenance staff oversee the operation of these critical systems.

The lift station system has about 8.5 miles of force mains, ranging from 4 to 30 inches in diameter. The Utility's force mains are made of concrete, asbestos cement (AC), polyvinyl chloride (PVC), or high density polyethylene (HDPE) as shown in Table 3.3.

Within Olympia's Sewer Service Area, the LOTT Alliance owns and operates another two lift stations and two miles of associated force mains.

Twenty eight of our lift stations are of a wet/dry well design with two separate below-grade chambers; the wet well holds the wastewater, and the dry well contains the pumps (usually two, which alternate pumping under normal conditions), controls and electrical equipment. In the other five stations, a pair of submersible pumps is contained within the same wet well chamber as the wastewater, and controls are in a separate panel located above grade or in a vault separate from the wet well.

The results of the assessment of physical condition and analysis of pumping capacity are presented in Chapter 10 as the basis for determining the need for lift station upgrades. Chapter 7 addresses the technical and staffing needs to support these systems.

Table 3.2
Lift Station and Force Main Inventory

	Name	Type	Generator	Force Main Size and Material	Construct Date	Upgrade Date
1	Water St. 1	Conc. Wet & dry wells	Yes	30" RCP	1961	1977
2	Water St. 2	Conc. Wet & dry wells	Yes	18" RCP	1961	2008
3	West Bay	Conc. Wet & dry wells	Yes	12" PVC (1985, 2012)	1961	1990, 2013
4	East Bay Drive	Flygt submersible	No	4" AC	1963	2009
5	Black Lake	Fairbanks Morse canned	Yes	6" AC	1966	2013
6	Woodcrest	Quince pneumatic ejector	No	4" AC	1968	2013
7	Holiday Hills	S&L canned	Yes	6" AC	1969	2013
8	Ken Lake	Paco submersible	Yes	4" AC	1969	1990
9	Roosevelt & Yew	S&L canned	Yes	6" AC	1970	
10	Miller & Central	S&L canned	Yes	8" AC	1970	
11	Goldcrest	S&L canned	Yes	6" HDPE (2012)	1970	2012
12	Jasper	Paco submersible	Yes	4" AC	1972	2010
13	Old Port 1	S&L canned	No	4" AC	1971	
14	Old Port 2	S&L canned	Yes	4" AC	1971	
15	Rossmoor	S&L canned	Yes	6" PVC	1978	
16	Motel 8	S&L canned	No	4" PVC	1979	
17	East Bay Marina	S&L canned	No	4" AC?	1982	
18	Ensign Road	S&L canned	Yes	10" PVC	1989	
19	Woodfield	S&L canned	No	4" PVC	1990	
20	Kempton Downs	Paco canned	Yes	6" PVC (2010)	1993	2012
21	Colonial Estates	S&L canned	No	4" PVC	1994	
22	Division & Farwell	Myers submersible	Yes	4" PVC	1995	
23	Miller & Ann	Cornell canned	No	6" PVC	1995	
24	Springer	Hydronix canned	No	6" PVC	1996	
25	Cedrona	S&L canned	Yes	6" PVC	1997	
26	Cooper Crest	S&L canned	Yes	6" PVC	2005	
27	Mud Bay	S&L canned	Yes	8" HDPE	2008	
28	Briggs	S&L canned	Yes	4" PVC	2008	
29	Division & Jackson	S&L canned	No	6" PVC	1957	2009
30	Sleater Kinney	S&L canned	No	6" HDPE	2010	
31	Yelm Hwy	S&L canned	Yes	10" HDPE	2011	

Table 3.3

Sanitary Sewer Force Main Inventory (feet)

Pipe Diameter (inches)	Concrete	Asbestos Cement	PVC	High Density Polyethylene	Ductile Iron/Cast Iron	Vitreous Clay	TOTAL
4		4,839	9,887		159		14,885
6		4,828	9,704	2,359	75	510	17,476
8		3,476		855	276		4,607
10		801	699	1496			2,996
12			2,880				2,880
18	108						108
30	1,948						1,948
Total lengths of each pipe type and % of total force main system length							
Feet	2,056	13,944	23,170	4,710	510	510	44,900
Miles	0.4	2.6	4.4	0.9	0.1	0.1	8.5
Percentage	5%	31%	52%	10%	1%	1%	100

3.3 STEP Systems

A septic tank effluent pump (STEP) system integrates the technologies of onsite sewage (septic) systems and gravity sewers. A STEP system service at a residence or business consists of a tank where solids are collected and a pump which moves the liquid waste via a low-pressure pipe into the gravity sanitary sewer system for treatment at the LOTT facility. The solids are pumped out regularly, usually at an interval of once every seven years for residential systems, and every one to four years for commercial systems.

In low-lying areas or flat terrain, STEP systems have some construction advantages over more expensive gravity sanitary sewers and lift stations. Pipes can be buried as shallow as 36 inches, and because they are pressurized and do not rely on gravity to maintain flow they can follow the terrain. Also, because only liquids are pumped, the pipe can be small diameter. As a result, installation costs are less than gravity systems that may need deep trenching.

However, maintenance costs of STEP systems are typically higher since pumps and associated equipment may break down and the tanks must be pumped periodically to remove the accumulated solids. Also, the anaerobic STEP system effluent produces hydrogen sulfide and other gases when exposed to air at locations of discharge to the gravity collection system. Hydrogen sulfide is odorous, requiring odor control techniques, and highly corrosive, damaging to unlined concrete gravity pipes and manholes.

Furthermore, under Washington State regulations, the City must own and maintain STEP systems and eventually replace them. City operations and maintenance staff are responsible for these systems. Failure of the STEP system pump or its associated pipe system can result in sewer overflows.

Figure 3.2 is a conceptual diagram of a STEP system. As with onsite sewage systems, each home, multi-unit residence, or business requires its own STEP system.

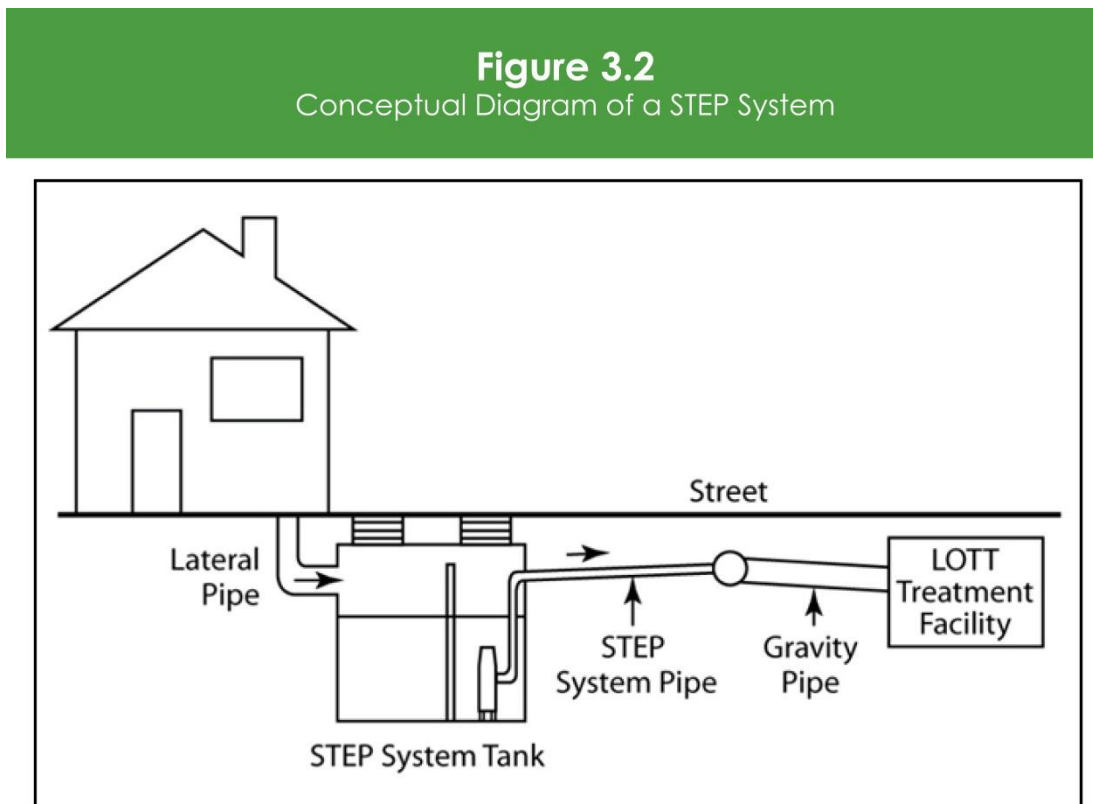

The Utility is currently responsible for a total of 1,860 STEP systems, including 20 commercial and multifamily STEP systems, serving approximately 12 percent of residential sewer customers with 29 miles of STEP sewer mains.

New STEP systems are not permitted in Olympia’s Sewer Service Area. All of the residential developments that were “vested” to use STEP systems are either under construction or have already been constructed. The only STEP systems allowed to be constructed now are for infill lots in existing residence subdivisions served by STEP systems.

The most extensive use of STEP systems is in southeast Olympia. Other areas are located in pockets in northeast Olympia UGA along Lilly Road; northwest Olympia UGA along Overhulse Road, 11th Avenue NW and 14th Avenue NW; and along the west slopes of West Bay and Capitol Lake. See Chapter 5 for more information on the locations and density of STEP connections and mains in each basin.

3.4 Grinder Pump Systems

A grinder pump system consists of a macerating (chopping) type pump that conveys sewage from a building through a small-diameter pressurized pipe to the City’s sewer collection system. The

grinder pump is typically located in a tank on private property. It is similar to a STEP system, but without the solids settling tank (Figure 3.2).

Before 2006, there was little effort to control the use of grinder pump systems, other than a general ban on “community” grinder pump systems, where a group of residences each have a grinder pump that connected to a common pressurized sewer main in the right-of-way.

Concurrently with the 2007 Wastewater Management Plan, the Olympia Comprehensive Plan was changed to allow the use of grinder pump systems only under certain conditions. Appendix O contains a copy of both the Grinder Pump Policy and Grinder Pump Maintenance Agreement template.

Unlike STEP systems, grinder pump systems are not owned or maintained by the City. However, the Department of Ecology’s Criteria For Sewage Works Design requires utilities to develop “uniform standards for system design, installation, operation, maintenance, and emergency response measures” for grinder pump systems. It also requires utilities to “maintain a library of operation and maintenance manuals for the type(s) of systems installed within their service territory.” For these reasons, and for consistency in design and reliability of service, the City only allows Environment One (E-one) grinder pumps to be used as part of a grinder pump connection to its sewer system. See Chapter 7 of the Olympia Engineering Design and Development Standards (EDDS) for more information on the specific pump type, required appurtenances, and design requirements.

Currently, there are approximately 140 grinder pumps in the Olympia sewer service area, all of which are owned and operated by the property owners. This accounts for less than 1% of our customers. The Utility owns just over one mile of grinder force main. See Chapter 5 for locations of current grinder pump connections in each basin.

3.5 Neighboring Jurisdictions (LOTT Clean Water Alliance Partners)

The City coordinates regional wastewater issues with the neighboring jurisdictions of Lacey, Tumwater and Thurston County through the LOTT Clean Water Alliance staff and board of elected officials (see Section 3.6). Specific development proposals located within Olympia’s UGA are coordinated by planners and engineers at the staff level. Common operational and maintenance issues are routinely handled with field staff coordination as needed.

There are a few instances of crossover between Olympia’s sewer system and the Lacey and Tumwater systems, particularly in areas where city boundaries are complex. Two examples are the region surrounding South Puget Sound Community College, where some pipes serve both Olympia and Tumwater customers but have not been identified as LOTT pipes, and the region north of North Street and East of Capitol Boulevard, where the Olympia and Tumwater border is complicated.

Coordination with neighboring jurisdictions will grow increasingly important as LOTT decentralizes wastewater treatment into satellite reclamation facilities. These facilities will require flow diversion schemes that may, for example, direct flow generated in Olympia into Lacey sewers to reach a satellite plant located in Lacey. The timing and phasing of LOTT satellite plant construction will depend upon flow availability and diversion of flow from each of the LOTT partners.

3.6 LOTT Clean Water Alliance

The LOTT Clean Water Alliance provides wastewater treatment and reclaimed water production services for the urbanized area of north Thurston County. Its four government partners (Lacey, Olympia, Tumwater and Thurston County) formed the LOTT partnership in 1976 to jointly construct and operate wastewater treatment facilities. In 2001 the partnership was reorganized as the LOTT Alliance (now LOTT Clean Water Alliance), an independent agency, with a governing board representing the four jurisdictions. A City Council member represents Olympia on the LOTT governing board. The four local Public Works Department directors serve on a technical advisory committee, known as the Technical Sub-Committee (TSC), which typically meets each month. Individual project issues are typically resolved at a staff level.

LOTT Treatment Facilities

LOTT's overall service area is about 82 square miles, of which approximately 36 square miles are currently served by public sewers. In the long term, the entire service area is expected to be served by community sewer. LOTT's member jurisdictions provide sewer service to a total of over 94,000 people and over 13,000 commercial and industrial customers.

LOTT's facilities currently include the central Budd Inlet Treatment Plant, the Hawk's Prairie satellite water reclamation facility in Lacey, major interceptor sewer lines and three regional lift stations. A second satellite facility may be constructed in the Chambers Prairie area of Lacey. Table 3.4 summarizes the volume of wastewater treated for the years 2006-2011.

The treatment of wastewater at LOTT has progressed from primary treatment for solids to advanced secondary treatment, including denitrification that meets and exceeds contemporary industry standards. Since 2005, a percentage of the final plant effluent has been treated to the more stringent reclaimed water standards, primarily for irrigation and industrial uses (see below and Tables 3.4 and 3.5).

About 16 miles of LOTT's interceptor mains and three lift stations are located in Olympia. Interceptors are located under Martin Way and Capitol Way, along Indian and Percival Creeks, along Black Lake and Cooper Point Roads, and around Capitol Lake. In many cases, the City of Olympia's neighborhood sewer systems connect directly into the LOTT interceptors. Because of these connections, potential problems or capacity-related issues affecting the LOTT system may directly impact Olympia wastewater customers.

Table 3.4

Volume of Wastewater Treated by LOTT (million gallons)*

	2006	2007	2008	2009	2010	2011
Budd Inlet Treatment Plant						
Daily Average	12.10	11.07	10.19	10.11	10.85	11.54
Minimum Monthly Average	8.40	8.67	8.31	8.53	8.33	8.97
Maximum Monthly Average	19.30	15.31	13.88	11.53	14.62	15.84
Peak Flow	38.19	48.48	26.36	48.64	33.18	33.81
Martin Way Reclaimed Water Plant						
Daily Average	0.67	0.67	0.57	1.00	1.04	0.65

* Source: LOTT 2012 State of the Utility Report.

Wastewater Resource Management Plan

LOTT's long-range Wastewater Resource Management Plan, completed in 1998 and updated annually, sets the stage for a decentralized approach to wastewater management in the Lacey-Olympia-Tumwater urban growth areas. As population grows and demand for wastewater treatment increases, LOTT will be recycling the additional wastewater instead of discharging it into Budd Inlet after treatment. Wastewater will be treated to Class A Reclaimed Water standards and re-used for non-potable purposes and groundwater recharge. As development occurs, small units of treatment and reuse capacity will be added "just in time." During the time needed to plan, design and build new recycling facilities, additional wastewater will be handled through reserve capacity in the Budd Inlet Treatment Plant for discharge to Budd Inlet and ongoing flow reduction projects.

LOTT's production of Class A Reclaimed Water began in 2005 with completion of the Reclaimed Water Facility at the Budd Inlet Treatment Plant. Construction of the first satellite facility, the Hawks Prairie Reclaimed Water Satellite in Lacey (also known as the Martin Way Reclaimed Water Plant), was completed in 2006. It diverts wastewater flows from Lacey that would otherwise have been conveyed to the Budd Inlet Treatment Plant. Martin Way has two million gallons per day (mgd) of treatment capacity, expandable to five mgd. Groundwater recharge basins in northeast Lacey will provide at least five mgd of recharge capacity. A second satellite facility may be constructed in the Chambers Prairie area of Lacey.

Table 3.5

Reclaimed Water Production Average, by LOTT (million gallons per day)*

	2006	2007	2008	2009	2010	2011
Budd Inlet Reclaimed Water Plant	0.50	0.46	0.38	0.42	0.44	0.49
Martin Way Reclaimed Water Plant	0.46	0.60	0.54	0.94	1.05	0.65
Total	0.96	1.06	0.92	1.36	1.49	1.14

* Source: LOTT 2012 State of the Utility Report

Note that Table 3.4 shows total water treatment by LOTT, and Table 3.5 shows reclaimed water production. The difference between the two values for any given year suggests the volume of treated water discharged to receiving waters.

LOTT's Wastewater Resource Management Plan is now known more familiarly as the "Highly Managed Plan" because it requires continual monitoring, planning and evaluation of future capacity needs. To identify changes or additions to planned capital projects or programs, LOTT annually analyzes flow and capacity - including treatment capacity, capacity to use or discharge treated water, and conveyance pipeline capacity.

To meet its facility plan requirements for wastewater treatment, the City of Olympia incorporates the LOTT Wastewater Resource Management Plan by reference into its Wastewater

Management Plan. This was authorized April 10, 2001 by Olympia City Council adoption of Ordinance 6097, which states:

The Olympia City Council hereby approves the LOTT Wastewater Resource Management Plan's Highly Managed Alternative, of November 1998, and directs that said Plan be incorporated into the City's Comprehensive Plan and General Sewer Plan at the time of the next update.

LOTT's Capital Improvement Projects

Like the City of Olympia, LOTT annually updates its Capital Improvements Plan (CIP). LOTT looks at its capital projects planning in both a near term (six-year) view, and a longer life-cycle (35-year) view. LOTT's 2012-2018 CIP, including its proposed 2012 Capital Budget, is summarized in Table 3.6.

Table 3.6
LOTT 2013 Capital Budget and 2013-2018 CIP*

Project Categories	2013 Capital Budget	2013-2018 CIP
System Capacity	\$21,098,812	\$52,848,617
New Capacity	\$4,538,995	\$10,237,521
Asset Management	\$2,969,411	\$5,108,504
Support Services and Projects	\$9,655,370	\$40,195,090
Total	\$38,262,587	\$108,389,732

* Source: LOTT 2013 Capital Budget and 2013-2018 Capital Improvements Plan

Near-term LOTT projects with direct implications to Olympia include:

- Interceptors/Manholes Inspection and Rehabilitation (Ongoing)
- Flow Monitoring Program (Ongoing)

3.7 Pretreatment

Industrial Pretreatment

LOTT's Industrial Pretreatment Program is designed to prevent pollutants from entering public conveyance and treatment facilities that could interfere with flow or operations, impact receiving water or biosolids quality, or threaten workers' safety.

Through regulations appended to the LOTT Interlocal Agreement (2000), the four LOTT partner jurisdictions have adopted identical pretreatment ordinances which are administered by the LOTT Clean Water Alliance. Local jurisdictions enforce the regulations with municipal codes (see Olympia Municipal Code Title 13 Chapter 20).

LOTT requires that discharges from permitted facilities meet industrial user permit requirements based upon federal categorical pretreatment standards and local limits. The pretreatment program includes provisions for monitoring, reporting and enforcement to ensure that potentially harmful substances are not introduced into the wastewater system. The program is updated as new users seek connections to the system, or as existing users change the pattern, quantity, quality or composition of discharge.

As of the end of 2011, there were nine Significant Industrial Users (SIUs) and 14 Minor Industrial Users permitted by LOTT in its service area. Table 3.7 summarizes those permittees that are located in the City of Olympia and discharge into the City's sewer collection system.

LOTT's annual Pretreatment Report has more detailed information regarding permittees as well as current and planned efforts under the Pretreatment Program.

Table 3.7
LOTT Industrial Pretreatment Permittees in Olympia

Industry	Type of Permit	Product	2011 Average Discharge (gpd)
Fish Brewing Co.	SIU	Beer	2,800
Crown Cork & Seal, Inc.	MIU	Aluminum Cans	23,000
Georgia-Pacific Corp.	MIU	Cardboard	2,100
J.R. Setina Manufacturing Co., Inc.	MIU	Vehicle Accessories	0 ¹
Roy's Designs, Inc.	MIU	Metal Coatings	0 ¹

¹ Zero discharge facilities with the potential for hazardous or non-permitted discharges are required to have an industrial user permit.

Fats, Oils and Grease

Most commercial food service establishments (FSE) produce waste products of fats, oils and grease (FOG) that if untreated at their source contribute to grease build up in the sewer collection system, leading to capacity and overflow problems, as well as treatment plant issues. City operation and maintenance staff regularly respond to conveyance problems associated with FOG. A byproduct of cooking, FOG comes from meat, fats, lard, oil, shortening, butter, margarine, food scraps, sauces, and dairy products. Grease abatement systems are required of all FSEs that produce FOG.

LOTT, in cooperation with the City of Olympia and its other partners, regularly surveys FSEs and provides technical assistance as needed to help FSEs reach compliance in addressing FOG. Enforcement of the pretreatment regulations related to FOG, codified in OMC 13.20, is the next step if an FSE does not respond to initial efforts to comply.

FSEs are not the only producers of FOG - residential wastewater can contain significant concentrations of FOG that can clog sewer service lines and gravity mains, and cause problems with the proper function of STEP tanks and grinder pump systems. Educational efforts geared toward reducing or eliminating this problem can be found at LOTT's Water Education and Technology (WET) Science Center, on the City's website, as well as through periodic mailings.



Households and businesses that are not connected to the City’s wastewater system must treat and dispose of their wastewater on site. There are approximately 4,145 onsite sewage systems (OSS), also called septic systems, in Olympia and its UGA - about 1,900 in the City and 2,245 in the UGA. Figure 4.1 shows an example map of the distribution of OSS in a select area of the City’s sewer service area. Complete mapping of parcels served by OSS within each watershed basin (see Chapter 5) can be found in Appendix M.

Onsite sewage systems have historically been the most common method of sewage treatment in Thurston County. Many parcels served by OSS were not connected to public sewers after the area was annexed, even though sewer pipes were laid in the general vicinity.

In the 1950s, reports of failing OSS and pollution of Capitol Lake and Budd Inlet made it clear that significant sewer infrastructure improvements were needed in the Olympia area. In the 1970s, concerns about public health risks associated with OSS led the Thurston County Board of Health to require inspection and certification of OSS.

Currently, both Thurston County and the City of Olympia regulate the permitting and use of onsite systems within Olympia’s Sewer Service Area (see Section 4.5 below for more details). Property owners are responsible for maintaining individual OSS, and the City operates the only community onsite sewage system (COSS) within its Sewer Service Area.

This chapter reviews the types and functioning of onsite systems, the potential public health risks associated with the systems, proximity of OSS to Olympia’s sewer system, potential costs of conversion to public sewer and the current regulatory framework.

Challenges associated with OSS in the City and UGA are introduced and discussed in this chapter, and summarized in Chapter 8. Note that this approach is different from the discussion of other challenges facing the Wastewater Utility, where the challenges are introduced in an earlier chapter but discussed in detail in Chapter 8. Goals and Strategies related to OSS are presented in Chapter 9.

Figure 4.1Parcels Served by Individual Onsite Sewage Systems¹

¹Example map; see Appendix M for basin-specific maps of parcels served by OSS.

4.1 Types of Onsite Systems

There are two main types of onsite sewage systems, individual (OSS) and community (COSS). Normally, OSS only serve one dwelling, one duplex or one business. COSS treat wastewater flows greater than 600 gallons per day (gpd) or flows discharged from three or more dwellings. Under state law, a public jurisdiction must own and operate COSS. In cities and their UGAs, COSS are considered an interim form of wastewater service, to be used only until public sewers become available. As part of the 1992 intergovernmental agreement with Thurston County (see Chapter 2), the City owns and maintains all COSS within the City's Sewer Service Area. Currently, there is only one COSS in Olympia's sewer service area, built in 1994 and serving three single family residences.

Larger onsite sewage systems, or LOSS, a type of COSS treating flows greater than 3,500 gpd, were regulated by Thurston County until 2011, and are now regulated by the Washington State Department of Health. There are no LOSS in the City or its UGA.

An OSS typically consists of a buried 500-1500 gallon, two-compartment “septic” tank and a drainfield. The tank collects sewage (wastewater) from the residential structure(s), which is then separated into (1) solids that settle and are broken down biologically by naturally occurring bacteria, (2) liquid that flows out of the tank and into the drainfield, and (3) fats, oils and grease (FOG) that float on top of the liquid in the tank and get partially broken down. In a properly functioning OSS, the liquid wastewater either flows out of the tank by gravity, or is pumped to the drainfield, where it is evenly distributed in the drainfield.

As the wastewater percolates through the drainfield and underlying soil, further filtration of the wastewater occurs, as well as additional biological treatment before it reaches groundwater. The solids and FOG need to be pumped out of the tank on a regular basis, typically once every three to ten years based on use.

Figure 4.2 is a conceptual diagram of an individual onsite sewage system (OSS), and Figure 4.3 shows a community onsite system (COSS).

Proper functioning of onsite sewage systems depends on the soil’s ability to process and filter the effluent. With the large silt fraction of soils in the South Puget Sound region, less than one percent of Thurston County soils are ideal for onsite sewage treatment, and 87% of the land by area is inappropriate for OSS. See the Geology and Soils section in Chapter 2.

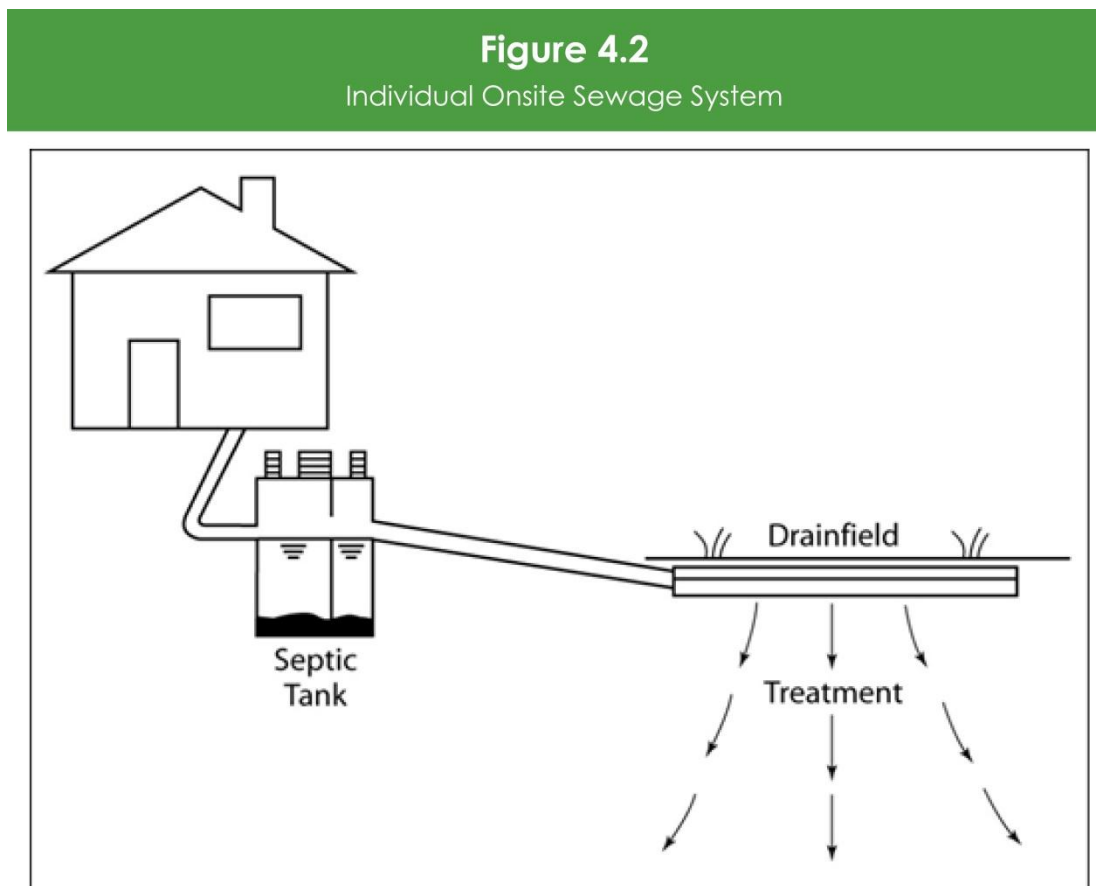
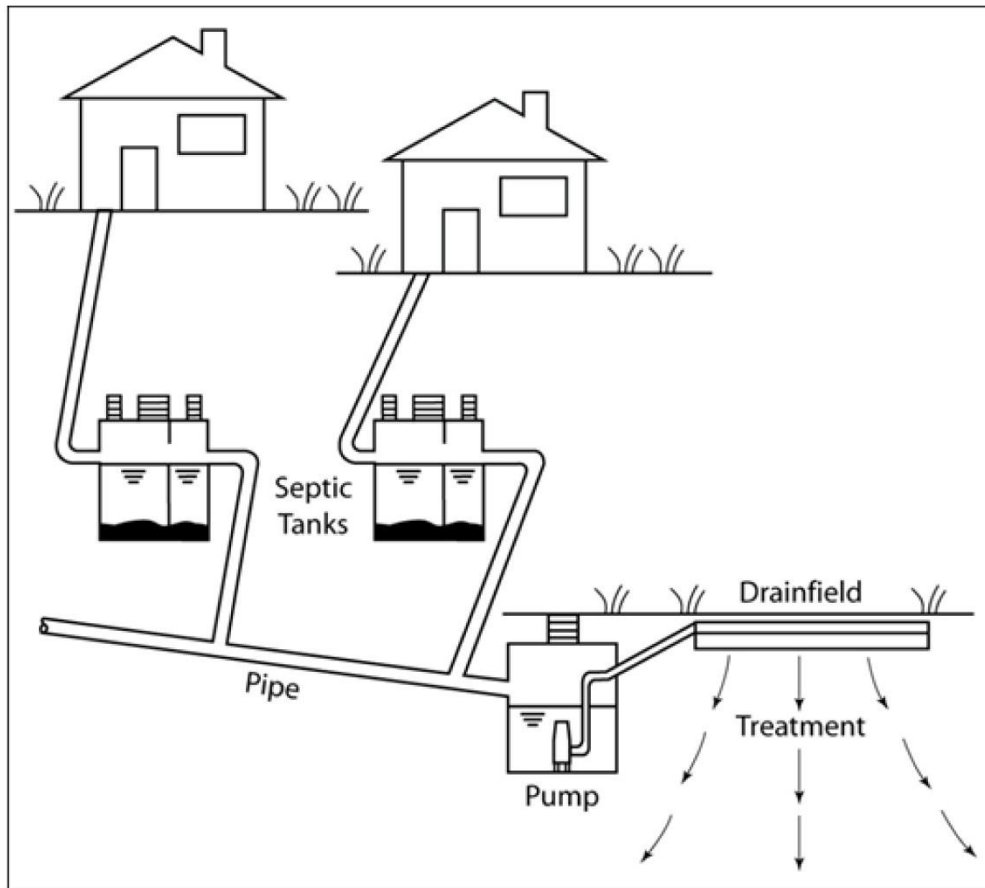

Figure 4.3
Community Onsite Sewage System



4.2 Public Health Risks of OSS in Urban Areas

Onsite sewage systems can be an effective and safe method of treating and disposing of treated wastewater when properly designed and installed, maintained regularly, and kept at moderate to low site densities. They are appropriate in rural areas, but were not intended for use in increasingly dense developed cities. They require a treatment and disposal area large enough to adequately break down and dilute effluent-borne contaminants.

The presence of over 4,000 OSS in the urbanizing area of Olympia and its UGA creates the potential risk to environmental and public health from groundwater, surface water and soil contamination. Figure 4.4 illustrates these risks.

Figure 4.4

Potential Risk to Groundwater and Surface Water from Onsite Sewage Systems

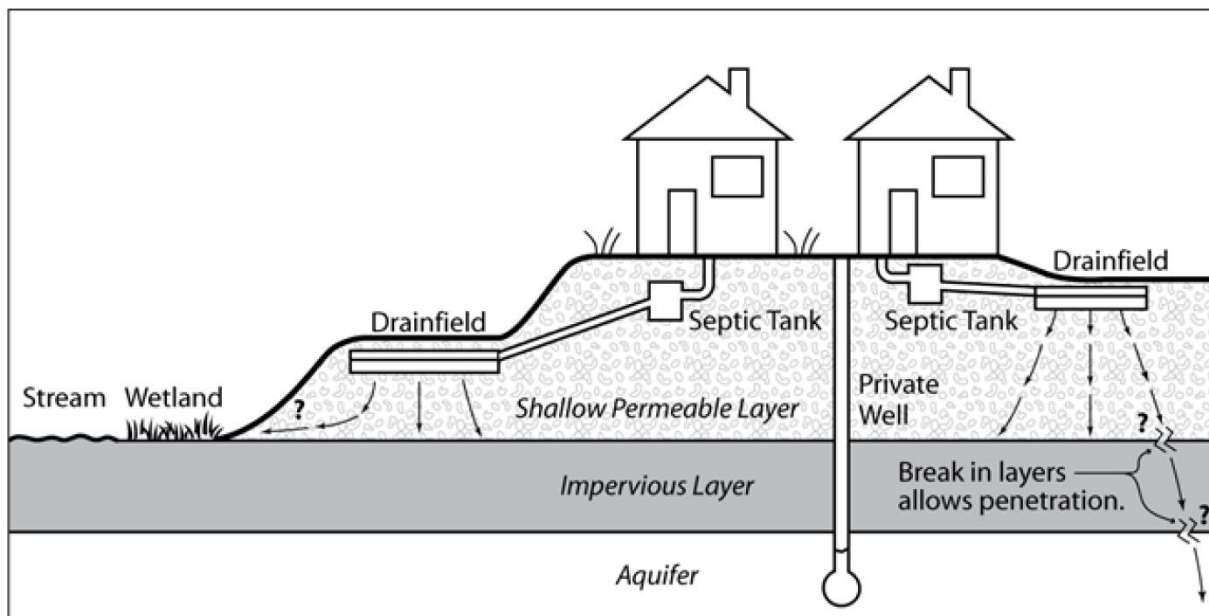

Risk of OSS Failure

Industry research has indicated that the design life of onsite sewage systems is generally 25 years, meaning the potential for failure increases with time, even if the system is properly sited and consistently maintained. However, records show some systems last much longer.

Onsite systems that are not properly sited and maintained may threaten water quality and public health by releasing bacteria, viruses, nitrogen, phosphorous, heavy metals and chemicals from household products into the environment. “Failure” means the system threatens public health because it is not adequately treating sewage or is creating a potential for people to come in contact with sewage. Examples of failure include:

- Sewage on the surface of the ground.
- Sewage discharged directly to surface water or onto the ground.
- Sewage backing up into a structure because of slow absorption of effluent by the soil.
- Sewage leaking from a tank, pump chamber, holding tank or collection system.
- Inadequately treated effluent contaminating ground water or surface water (determined by dye tracing and/or fecal coliform count).

- Surface or ground water intrusion into a tank, pump chamber, holding tank, or collection system.
- Cesspools.
- Seepage pits where there is evidence of ground or surface water quality degradation.

Evidence of Contamination from OSS

Onsite systems, especially when used at urban densities, create threats to both groundwater and surface water. Nitrates are a common groundwater contaminant associated with OSS, while bacteria linked to OSS are often found in surface water.

Nitrate is increasingly observed in groundwater, including the City's drinking water supply wells in Southeast Olympia. In some cases, the concentration of nitrate threatens the viability of both private and public drinking water supplies. Onsite systems have been identified as a significant contributor to the problem through detailed studies conducted in the 1990s and 2000s.

In addition, bacterial contamination from failing onsite systems is one of the principal causes of shellfish restrictions imposed on Puget Sound since 1980 (Grover 1996). Ongoing water quality monitoring confirms that streams and marine waters within Olympia have elevated levels of bacterial contamination.

Guidance on Siting of OSS

Research demonstrates that properly functioning onsite sewage systems can pollute ground and surface water if they are concentrated in too small a land area (DeFeo, 1991; Yates, 1985). In Olympia and its UGA, an estimated 41 percent of onsite systems are sited on lots less than the minimum recommended lot size of 12,500 square feet (WAC 246-272-20501; Article IV, Section 21). Similarly, ground and surface water quality impacts have been observed where the average density of OSS is more than four systems per acre, even in well-drained soils (Brown and Bicki 1987, 1991). The maximum density of OSS in Olympia's sewer service area is approximately 4 systems per acre, in areas of the southeast UGA. More typical densities in areas with OSS are less than 2 systems per acre. As a comparison, all of Olympia and its UGA is zoned or planned for densities with residential lot sizes of approximately 5,000 square feet or about 8.7 lots per acre.

Additional guidance recommends that OSS should be adequately separated from drinking water wells. Analysis on virus mortality and migration suggests that OSS should be at least 400 feet apart to reduce virus concentrations below safe drinking water standards in the groundwater (Brown & Bicki 1997, 1991; LOTT 1998). Under current County regulations if a lot is served by a private well, the minimum lot size for an onsite sewage system is one acre (Article IV, Section 21). In addition, new onsite systems must be located at least 100 feet from a water supply source or other surface water and 200 feet from a public drinking water supply (WAC 246-272-09501; Article IV, Section 10).

Under State regulations, onsite systems cannot be installed within 100 feet of fresh or marine surface water (WAC 272-0950). With waivers, Thurston County maintains authority to reduce the buffer distance to 50 feet. Under Olympia’s Critical Areas Ordinance, onsite sewage systems are not allowed in designated critical areas (e.g., wetlands and floodplains).

Table 4.1 summarizes the siting and characteristics of OSS in Olympia.

Table 4.1

Onsite Sewage System Characteristics (Olympia and its UGA)

Onsite Sewage System Characteristic	Approximate To-	% of Total ¹
1. Lots less than 12,500 sq. ft.	1,684	41
2. Lots with drinking water wells (100 ft. from well required by WAC, 400 ft. between OSS recommended)	1165	28
3. Lots within 100 ft. of surface water	350	8
4. Lots within Olympia drinking water protection areas	827	20
5. Lots within Olympia portion of Henderson Inlet Watershed Protection Area	762	18

¹Percentage adds up to more than 100 since some OSS meet more than one of the characteristics in this table.

Assessment of Current Risks in Olympia

In response to increasing concern over the prevalence of OSS in the Lacey-Olympia-Tumwater area, Thurston County Environmental Health Program recently completed a planning-level analysis of existing OSS use and their environmental risks. The analysis used GIS technology to link the various densities of OSS in neighborhoods to screening criteria defining potential risks to both surface and ground water. This information provides a productive planning-level tool for considering jurisdictional needs for OSS policies and regulations, and the potential need to convert systems to the municipal sewer system.

The analysis documented the occurrence of individual onsite systems in the north Thurston County area. Areas with OSS were subsequently grouped into neighborhoods based on subdivision plats or lots that share similar characteristics. Commercial and multifamily OSS were converted to a single family residential equivalency unit. Onsite septic densities in the neighborhoods were calculated and grouped as follows: ≤ 1 OSS unit/neighborhood acre, 1-2 units/acre, 2 to 4 units/acre, and ≥ 4 units/acre. With this analysis the density of onsite systems is a key risk factor.

Given onsite densities, several natural resource parameters were used to refine the potential threat to both surface water and groundwater. The risk of surface water contamination from onsite systems increases with neighborhoods that are close to water bodies and that have soils that generate runoff rather than infiltrate. When combined with neighborhoods with relatively high densities of OSS, these geographic traits create a higher potential of contamination. Similarly, neighborhoods located within drinking water protection areas and with soils that readily infiltrate precipitation to groundwater generate relatively high risks to groundwater. Additional parameters and site specific information can also be used to supplement the basic evaluation.

The outcomes of the analysis suggest the following concerns for Olympia:

- OSS densities are typically relatively low. Isolated pockets of densities ranging from 2-4 units/acre are located in the extreme NE corner of Olympia (Sleater-Kinney Road) and SE Olympia. Within the City's UGA, areas along Yelm Highway also have higher densities.
- Much of Olympia is potentially susceptible to surface water contamination due to relatively impermeable soils and the proximity of water bodies. However, when combined with the typical low density of OSS within Olympia, these natural traits do not create many high risk areas. The Sleater-Kinney Road area north of Martin Way stands out as the only relatively high risk area.
- From a groundwater perspective, the impermeable soils in Olympia do not facilitate a lot of infiltration and subsequent contamination. Additionally, few drinking water protection areas are located in Olympia. Several potentially problematic areas are located in SE Olympia along Yelm Highway.

The analysis highlights few neighborhoods with both OSS densities and natural traits with the potential to create regionally-significant water quality problems. However, the analysis does not suggest that failing individual onsite systems are not a problem. We are aware of individual OSS generating both surface and groundwater contamination.

The analysis does indicate that from a regional planning perspective the implications of onsite systems in Olympia may be modest. Maps depicting the outcomes of the analysis are provided in Appendix M. Chapters 8 and 9 further address OSS challenges and recommendations as well.

4.3 Proximity of OSS to Olympia Sewer System

Onsite systems are distributed throughout Olympia and its UGA. As surrounding homes and neighborhoods developed on public sewer, isolated or small pockets of systems have remained. Other areas such as portions of Northeast and Southeast Olympia include entire subdivisions served by onsite systems. Additionally, many undeveloped infill parcels remain in Olympia. At some point, most of these isolated parcels will develop and need sewer service.

In general, current City policies require a developing parcel or a failing existing OSS to connect to the public system if located within 300 feet of the sewer pipe. Existing lots greater than 1 acre are exempted from the requirement. Of the 4,145 onsite systems in Olympia and its UGA, over 1,200 are within 300 feet of public sewer. As shown in Table 4.2, an estimated 1,000 systems in the City and 1,900 in the UGA are further than 300 feet from sewer and could be connected if sewers were extended. The table also shows the distribution of onsite systems in relationship to existing sewers.

Table 4.2

Proximity of Onsite Sewage Systems to Public Sewer

	Adjacent to Sewer Main	Within 200 feet	Between 200 and 300 feet	Over 300 feet	Total
Within City limits	537	265	102	998	1,902
UGA	243	71	50	1,879	2,243
Total	780	336	152	2,877	4,145

Table 4.3

Characteristics of Undeveloped Parcels Related to Onsite Sewage System Permitting¹

	Within 300 feet	Over 300 feet and < 1 acre	Over 300 feet and > 1 acre	Total
Within City limits	1,641	202	75	1,918
UGA	216	180	94	490
Total	1,857	382	169	2,408

¹Not all undeveloped parcels are developable

Many undeveloped parcels are within a feasible connection distance to the public system. Table 4.3 shows characteristics of undeveloped lots in relationship to existing sewers and permitting.

4.4 Potential Costs of Converting OSS to Public Sewer

For owners of onsite systems, the cost of connecting to City sewer can be substantial. Table 4.4 summarizes the potential costs of conversion and highlights the high degree of variability of construction costs.

Table 4.4

Typical Costs for Converting an OSS to Public Sewer

Item		Range of Costs*
Construction Costs		
1	Public Sewer Infrastructure (if not existing)	\$15,000 - \$25,000+
2	Side Sewer Construction to House (high end is for grinder pump or STEP connection)	\$3,000 - \$10,000
3	Septic Tank Abandonment	\$800 - \$1,200
Construction Subtotal =		\$4,000 - \$36,000+
2013 Applicable Fees and Permits		
4	LOTT CDC (Capacity Development Charge)	\$4,719
5	City Wastewater GFC (General Facility Charge)	0** or \$3,199
6	Permits for Sewer Connection	\$147 - \$1,200
7	Septic Tank Abandonment Permit (Thurston Co.)	\$210
Connection Fees Subtotal =		\$5,076 - \$9,328
Range of Total Costs to Convert		\$9,000 - \$45,000+

* In 2013 dollars; rounded figures.

** The City Wastewater GFC is waived per OMC 13.08.205(C) for properties with an existing onsite sewage system that connects to the sewer within two years of notice of sewer availability.

Through its Septic to Sewer Program, the City assists homeowners on an OSS to convert to public sewer. The program includes the following components:

- Public education and outreach
- General Facility Charge Waivers
- Neighborhood Sewer Extension Program
- Other services identified in the Strategies section of Chapter 9

The number of OSS conversions to public sewer has increased in recent years from an average of 6 conversions per year between 1992 and 2008 to an average of 23 conversions per year between 2009 and 2012. The increased rate of conversion corresponds with implementation of the City's Septic to Sewer conversion program. More information on this program's services is available on the City webpage.

4.5 Current Regulations

Privately owned individual onsite sewage systems (OSS) and community onsite sewage systems (COSS) are regulated by the Thurston County Board of Health. The County Environmental Health Division is responsible for reviewing permit applications for new onsite sewage systems and repair or expansion of existing systems. Its staff maintains onsite system records, and oversees the inspection of onsite systems before property ownership is transferred.

This section summarizes the regulatory framework for individual and community onsite systems, special regulations for the Henderson Watershed Protection Area and pending regulations on underground greywater irrigation systems.

Individual Onsite Sewage Systems (OSS)

The City has no responsibility for owning, maintaining or managing private individual OSS. However, the City does have the authority within its Sewer Service Area to determine if a new onsite system or repairs to an existing onsite system is allowable, or whether the proposed or existing building(s) is required to connect to the City's sewer system. Therefore, Thurston County forwards all OSS repair or new construction applications for sites located in the City or its UGA to the City for review and approval or rejection. See Appendix P for a flowchart that guides City and County staff in determining whether or not a proposed OSS can be permitted within the City or its UGA.

City regulations for permitting new OSS are more restrictive than State and County regulations. Under current State and County regulations (WAC 246-272A-C and Article IV of the Thurston County Sanitary Code, respectively), new OSS are allowed under certain conditions, most importantly when the following conditions can be met: it can function properly, it is located in suitable soils at a safe distance from a water well, and no public gravity line is accessible. Under State and County standards, OSS served by a public water system must be located on lots of at least 12,500 sq. ft. (with a density of 3.5 lots per acre or less); the County code allows OSS on smaller lots of record (i.e. lots created before 1995) if they meet other criteria (WAC 246-272A-0210 and WAC 246-272A-0320). City permitting regulations restrict new OSS to parcels that are more than 300 feet from a municipal sewer system and for a historical parcel greater than one acre in size. Replacing existing OSS 300 feet from municipal sewer also can be permitted.

New OSS owners in the UGA must sign an annexation agreement and all new OSS in the City and UGA must be designed as interim and agree to connect within one year of being notified to do so.

The County Health Code requires owners of larger or more complex systems to have them certified and inspected every one to three years. High-risk OSS located in the Henderson Watershed have more stringent requirements (see below). A City-County Resolution (Olympia Ordinance 5861) also encouraged owners of onsite sewage systems to register with the Thurston County Operational Certificate Program. Olympia Water

Resources cooperates with Thurston County in periodic educational activities to encourage proper maintenance by onsite sewage system owners.

Community Onsite Sewage Systems (COSS)

Community onsite sewage systems (COSS) are considered by the Department of Ecology to be public sewerage treatment facilities, requiring the City to assume ownership and maintenance responsibility. Under an October 1992 intergovernmental agreement with Thurston County, the cities of Olympia, Lacey and Tumwater own and operate COSS within their UGAs. Public ownership is meant to encourage development within the UGA in the interim before public sewers are extended, and to ensure consistent Wastewater Utility services to all customers as mandated by the Growth Management Act.

Olympia policy allows approval of a COSS only if topography or other constraints preclude connection to the public sewer, and if the cost of extending the sewer exceeds COSS installation and lifecycle costs by 50 percent. Before the City takes over ownership and maintenance of a COSS, the developer must pay all up-front connection fees to the City sewer system, including the CDC and GFC. Customers connected to a COSS must agree to pay the regular monthly sewer utility rate, and connect to the City's sewer system within one year after sewer becomes available, including paying any connection fees not previously paid to the City at the time of connection to the COSS.

COSS are considered interim systems and must be designed for efficient conversion to sanitary sewer. COSS permits in the UGA require that property owners sign an agreement to support an annexation petition, to take effect when the area becomes contiguous to the City.

Currently, Olympia maintains one COSS, located on Devoe Road in the UGA.

Henderson Watershed Protection Area

In May 2004, a Thurston County citizen advisory committee recommended a program to enforce onsite sewage system maintenance in the Henderson Inlet watershed (see Figure 4.4), where fecal coliform bacteria from human waste are contributing to the pollution in streams and marine waters (Thurston County, 2002). Woodland and Woodard Creeks, which capture runoff from northeast Olympia, Lacey and Thurston County, are on Washington State's 303(d) list of water quality impaired water bodies, a list maintained as a requirement of the federal Clean Water Act. The Olympia portion of these basins includes parcels with 762 onsite sewage systems, 444 within the City limits and 318 in Olympia's UGA.

Based on the committee's recommendations, Thurston County approved its first mandatory onsite sewage system operation and maintenance program to help restore water quality. The program requires that all onsite systems within the existing shellfish district be inspected on a regular basis and that owners maintain a current County

Operational Certificate. See the most recent version of Article IV of the Sanitary Code for Thurston County for more information regarding this program.

Figure 4.5

Henderson Watershed Protection Area

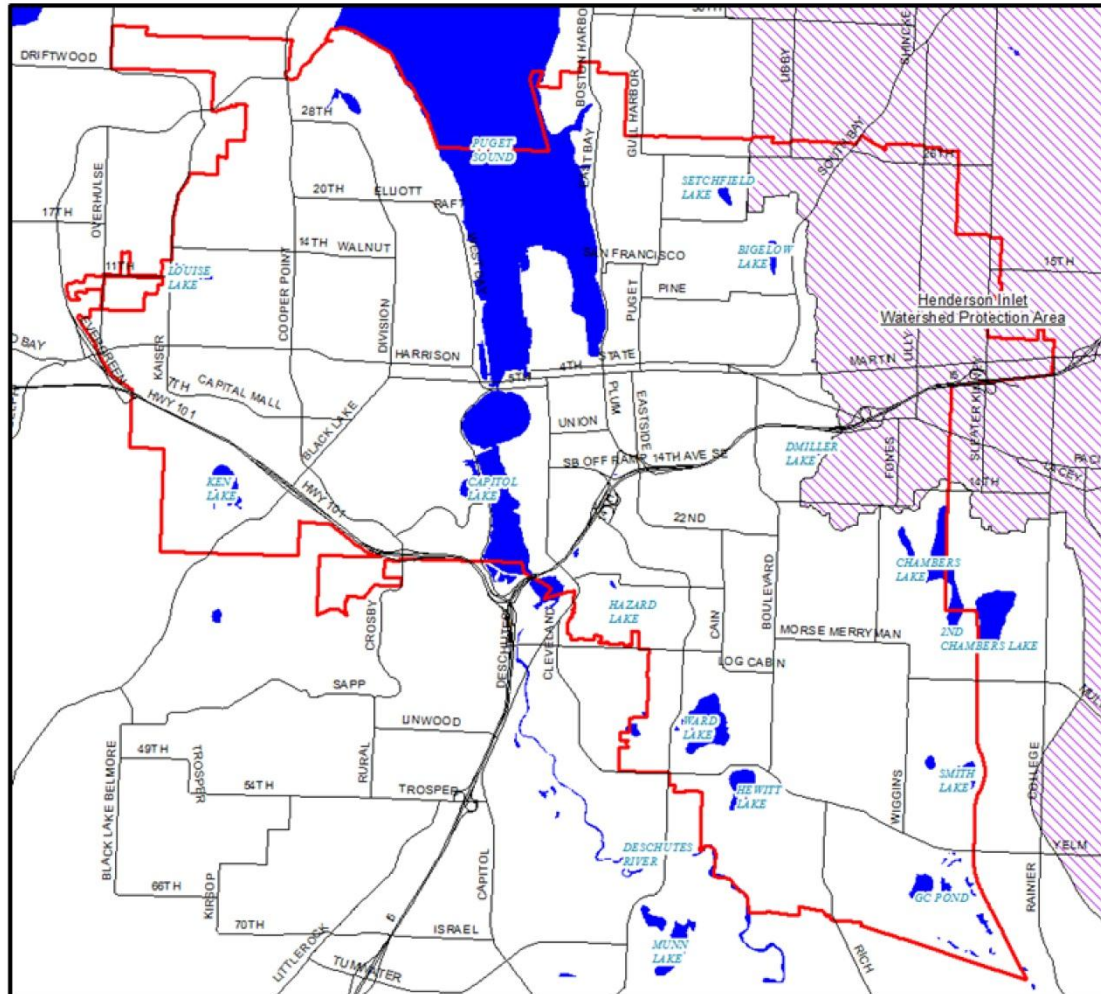

Greywater Subsurface Irrigation Systems

The Washington State legislature recognizes the need to conserve ground and surface water supplies, reduce the cost of treating wastewater and use sustainable building practices to conserve potable water. The legislature determined that the Department of Health shall adopt rules for greywater reuse that do not compromise public health or cause unacceptable environmental impact.

In 2006, enacted legislation required the Washington State Department of Health to adopt rules for subsurface greywater irrigation by December 31, 2010. The rule, chapter 246-274 WAC, establishes requirements that provide building owners with simple, cost-effective options for reusing greywater for subsurface irrigation. The chapter is intended to encourage water conservation and to protect public health and water quality.

- Quoted from the Preface of the Washington State Department of Health's draft guidance document titled "Tier Two and Three Greywater Subsurface Irrigation Systems" (May 2011).

Tier 1 greywater systems are the simplest with up to 60 gallons per day of gravity flow. Tier 2 systems distribute up to 3,500 gallons per day, and typically rely upon pressurized flow. Allowable greywater sources for both Tiers 1 and 2 systems are bathroom sinks, showers, bath tubs and clothes washing machines. Tier 3 systems are similar to Tier 2, but typically use greywater from sources such as non-laundry utility sinks, kitchen sinks and dishwasher water.

The most likely scenario for implementing greywater reuse for subsurface irrigation is for property owners already connected to City sewer to divert some of their greywater, on a seasonal (when it is not raining or freezing) and occasional basis for watering plants.

According to 246-274 WAC, Thurston County has three years from July 31, 2011 to either adopt the new WAC by reference, or write and adopt local codes to address greywater re-use, consistent with the WAC.

Until Thurston County adopts code language addressing this, greywater reuse for subsurface irrigation is not allowed. However, residents can get an onsite greywater sewage system approved under 246-272A WAC, for example if they have a composting toilet and still need to treat/dispose of the greywater. Under current City and Thurston County regulations, residents would only be able to do this in locations where it is acceptable to site onsite sewage systems. This regulatory approach provides system redundancy.

Watershed Basin

Chapter 5

In Chapters 3 and 4, we described Olympia’s wastewater system in terms of system components: gravity sewers, lift stations, STEP systems, grinder pump systems and onsite sewage systems. In this chapter, we begin looking at the system from a watershed perspective. By doing so, we can begin relating wastewater management to overall water resource management issues.

Surface and ground waters in the City’s Sewer Service Area drain naturally in different directions to various water bodies. Each of these water bodies has water quality characteristics and management needs that can be influenced by wastewater decisions. In many cases, these characteristics and needs relate directly to the wastewater challenges discussed in Chapter 8.

While the watershed basins are regional in nature and typically extend beyond the Olympia Sewer Service Area, this analysis is limited to the portion of the basin that is within the City’s sewer service area. Each watershed basin is briefly described in terms of receiving waters, existing infrastructure, projected development, wastewater flow, number of STEP and onsite sewage systems, water quality issues and specific challenges. Additionally, the maps in Appendix M show the location of gravity sewers, lift stations and force mains, STEP lines and tanks, and onsite sewage systems (OSS) within each basin.

The watershed basins are delineated in Figure 5.1. Each watershed basin contains a unique mix of wastewater infrastructure that interacts with the basin’s receiving waters. Table 5.1 summarizes the basin’s wastewater characteristics.

Table 5.1
Wastewater Characteristics of each Watershed Basin

Characteristic	Central	Kettles	NE	SE	SW	NW	Totals
Existing OSS within 300' of Sewer	528	354	217	51	22	113	1,285
Total existing OSS	1,197	833	759	1,010	41	305	4,145
STEP Systems	68	605	358	705	8	116	1,860
Grinder Pumps	55	44	5	0	1	36	141
Lift Stations	14	1	5	4	2	4	30
Single-family Residential	7,110	2,538	613	727	823	1,593	13,704
Multi-family Residential	322	17	128	30	256	90	843
Commercial Customers	973	42	269	5	332	59	1,680
Total Sewer Customers	8,405	2,597	1,010	762	1,411	1,742	16,227
% Basin Undeveloped ¹	14%	19%	23%	31%	18%	22%	

¹ Total undeveloped area of basin, not including parks and other public places, as a percentage of total basin area.

Figure 5.1

Olympia's Watershed Basins

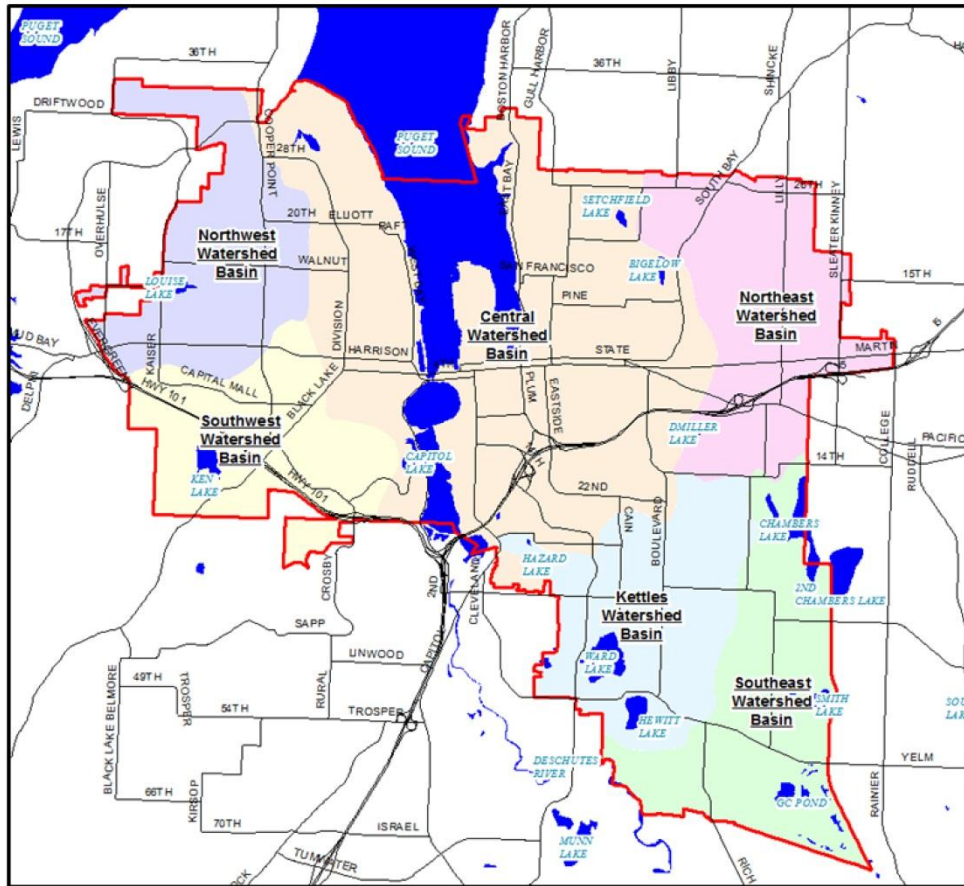

5.1 Central Watershed Basin

The Central basin (Figure 5.2) encompasses the older developed areas of Olympia. It is dominated by the central business district; the Ellis, Mission and Indian Creek watersheds on the east and south side; and that part of the near west side of the City and its Urban Growth Area (UGA) that drains to Capitol Lake or Budd Inlet. Population and business density in the basin is high.

The precipitation, surface water and ground water within the Central basin discharge to Budd Inlet. Contaminants from many sources, potentially including wastewater, affect the Inlet's water quality. Water quality concerns from a wastewater perspective include bacteria, nutrients, various contaminants of emerging concern, and potential reductions in dissolved oxygen. Most of the City's water quality monitoring data focuses on Budd Inlet and its tributary waters. Budd Inlet is the focus of extensive technical analysis and regulation.

Much of this basin is already developed (86%) with future development largely limited to redevelopment and small new developments. Wastewater flows are not expected to increase appreciably. The anticipated increase in peak wastewater flows is only one percent through 2025. Nearly all of this projected increase is expected to come from conversion of onsite

sewage systems (OSS) to gravity sewers, infill residential and commercial development/redevelopment. The existing wastewater collection system in the Central basin typically has adequate capacity and facilitates the connection of new development to public sewer.

Figure 5.2
Central Watershed Basin

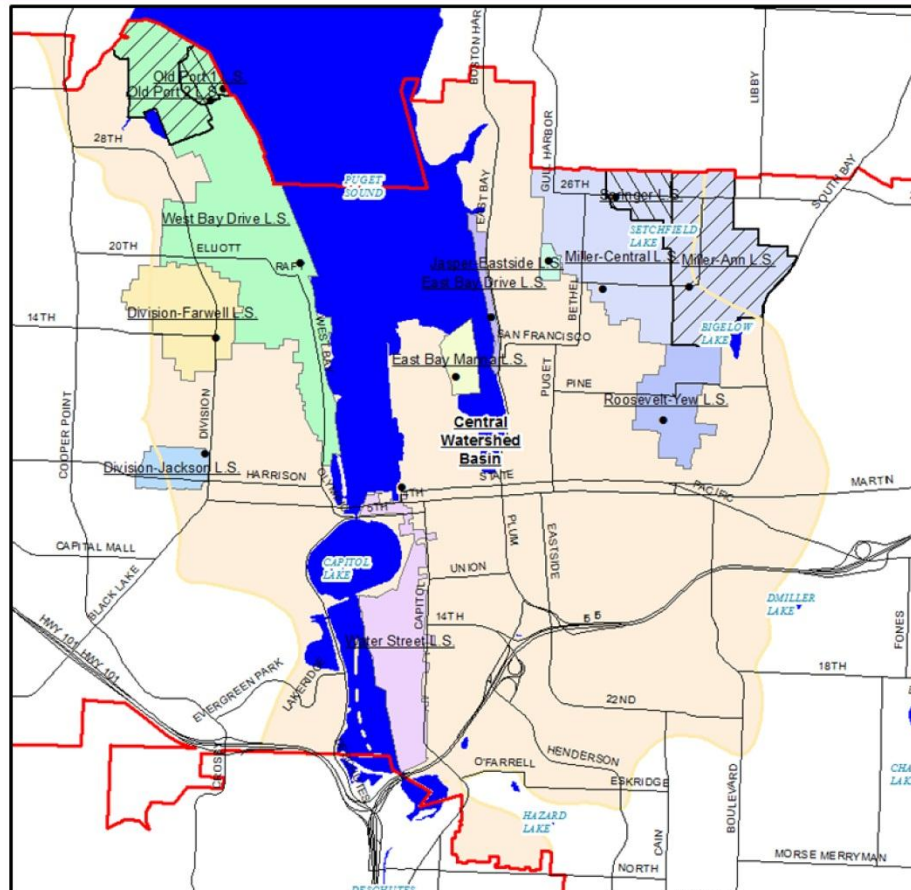

The main challenge with the wastewater collection system in the Central basin is its age. Many pipes are well over 50 years in age. With age, the pipes become susceptible to structural deterioration, collapse, and increased infiltration and exfiltration. Infiltration occurs when groundwater enters the wastewater pipe through cracks. Similarly, wastewater can leave the pipe and enter soils and groundwater (exfiltration). Operation and maintenance needs in the basin are typically greater and more intricate than other basins.

The Central basin also contains the City's highest percentage of combined wastewater/stormwater pipes. The combined system collects stormwater from streets and buildings and routes it to LOTT's Budd Inlet treatment facility through wastewater pipes. The wastewater flow model developed in 2007 estimated that peak flows associated with storm events in the Central basin are 23 times higher than base flows. These high flows reflect the

concentration of stormwater inflow through the combined sewer/stormwater pipes in the downtown core. They can tax the capacity of otherwise adequately sized wastewater pipes.

Key lift stations, including the large Water Street station, are essential to the operation of the Central basin wastewater system. Over 40% of the 33 lift stations in the City's wastewater collection system are located in the Central basin. The service areas of the neighborhood lift stations (LS) are delineated in Figure 5.2.

Given its evolution over time, the Central basin's sewer system is complex and sometimes challenging to analyze. The management of these pipe systems focuses on refining our understanding of the system and maintaining its integrity as it ages. Pipe maintenance and upgrades in this basin are costly.

The basin has only 68 STEP systems, but high numbers of OSS. Like the sewer collection system pipes, many of the 1,197 OSS in the basin have reached or exceeded their expected operational life. Approximately 44 percent of the OSS are within 300 feet of a public sewer system and could conceivably connect. However, pockets of OSS located more than several hundred feet from the sewer will remain financially challenged to connect.

The complex, aging public infrastructure combined with large numbers of OSS create the potential for water quality impacts to Budd Inlet. State efforts through Clean Water Act water quality studies are underway to improve water quality in Budd Inlet. From a water quality perspective, the Central basin is carefully managed to prevent spills, correct unintentional cross connections with stormwater systems, and ensure the structural integrity of the pipes.

5.2 Kettles Watershed Basin

The Kettles basin (Figure 5.3) is located southeast of the Central basin. It includes some of the initial residential neighborhoods that were developed as Olympia spread to the southeast in the 1950s-1970s. Development pressure remains strong in this basin. New development in the basin will include subdivisions, infill, redevelopment, and some light commercial.

Surface water in the Kettles basin drains to Ward and Hewitt Lakes and a number of other nearby kettles or depressions left by remnant ice from the retreating glaciers. These lakes and kettles infiltrate surface waters to groundwater. Some soils in this basin infiltrate well. Unidentified wastewater cross connections into stormwater infrastructure, leaking wastewater pipes and OSS can result in adverse impacts to groundwater quality in this basin.

The public sewer system in the Kettle basin is relatively contemporary, but is comprised of a fragmented mix of gravity pipes, lift stations, STEPs, grinder pumps, and OSS. The basin's inconsistent topography resulted in this mix of wastewater technologies. The basin has a relatively large number of STEP systems (605) and OSS (833) for its total area. It is dominated by single family development.

The recent Yelm Highway road improvement project included extensive upgrades to City utilities. Wastewater pipes, pumps, and odor control facilities were incorporated into the road work. These wastewater improvements provide the basis for continued expansion of the public sewer systems in this basin as well as the adjacent Southeast basin.

Figure 5.3

Kettles Watershed Basin

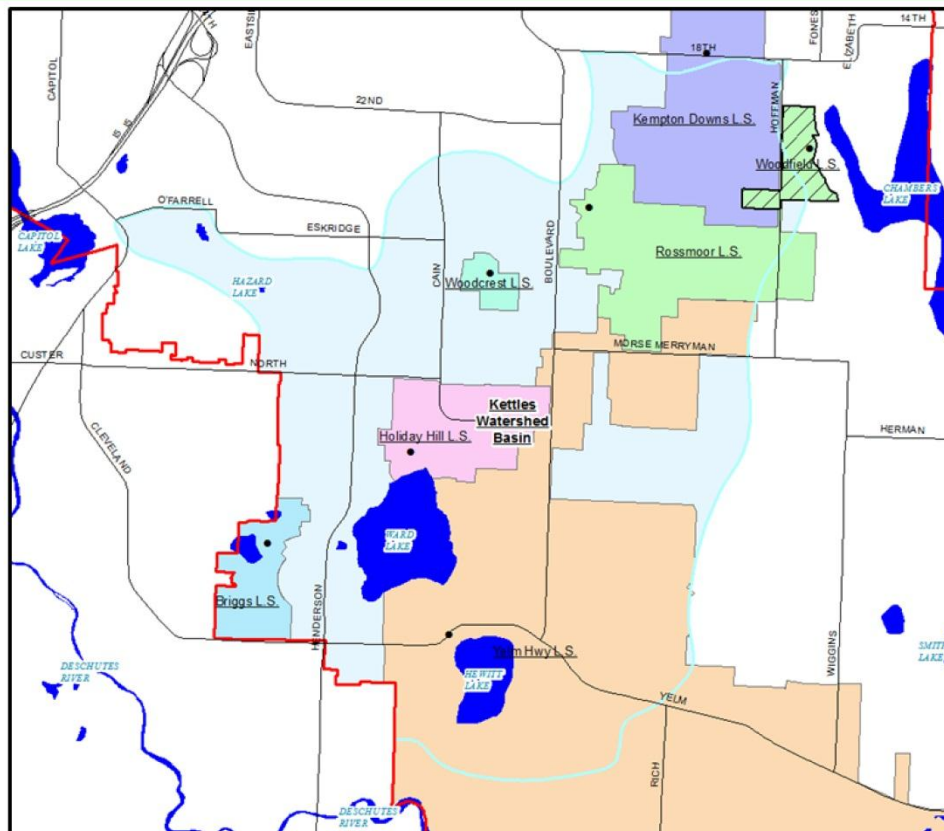

Ongoing new development in the basin prompts the need for carefully managed sewer extensions that facilitate the new development as well as existing developments. In concert with the Southeast basin, wastewater management in this basin requires understanding and coordination of pipe systems and networks.

5.3 Northeast Watershed Basin

The Northeast watershed basin (Figure 5.4) can be challenging from both wastewater and water resource management perspectives. Both topographical and development patterns make public sewer systems difficult to link into a regional system. Areas of relatively low development density and pockets of OSS hamper the orderly expansion of the sewer system.

The Northeast basin is within the Henderson Inlet Watershed Protection Area, a water quality and shellfish harvesting priority. The basin drains in a northerly direction to Woodard Creek and subsequently to Woodard Bay in Henderson Inlet. Historical bacterial contamination in Henderson Inlet has declined in recent years with the shellfish beds once again productive and commercially viable. Management of public and private wastewater systems is a key aspect of maintaining the Inlet's shellfish industry.

Topographically, the basin slopes in various directions, depending on location relative to the nearest surface water. There are several lakes and ponds. Streams generally flow south to north. The main sewer lines in the basin flow north to south, along East Bay Drive, Lilly Road and Sleater Kinney Road. Secondary sewer pipes and lift stations collect and transport wastewater into these main lines. Flows subsequently travel west in the LOTT systems. Wastewater pipes in the basin range from older to contemporary systems. This basin includes many smaller basins that will likely require some method of pumped sewer service to connect to the existing collection system.

This basin is projected to experience a variable rate of development over the next 25 years, generally increasing from west to east. Development becomes increasingly residential, and less dense, in the northern portions of the basin. Light commercial development is scattered throughout, though there are concentrations in the Lilly Road and Sleater Kinney Road areas. The Lilly Road area also includes the Providence/St. Peters Hospital and Group Health Medical Center, along with ancillary medical practices in the immediate vicinity.

Figure 5.4

Northeast Watershed Basin

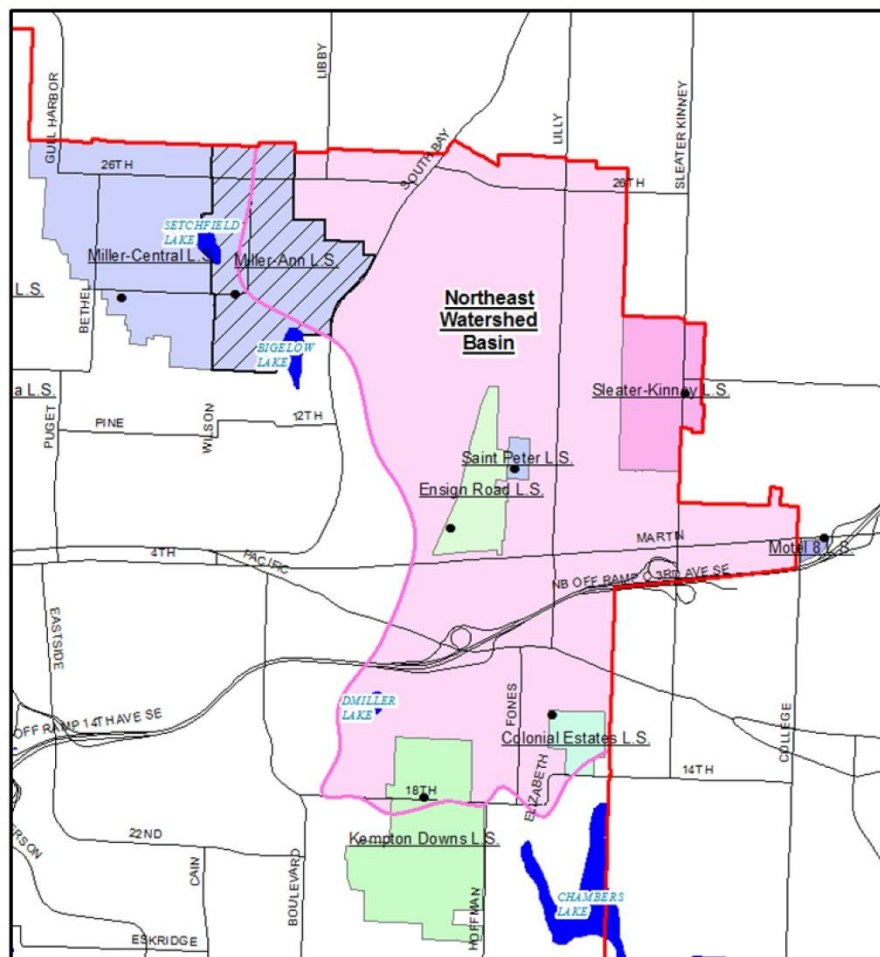

The Northeast basin has 358 STEP systems and 759 onsite sewage systems. Many of the OSS are located in the Henderson Inlet Watershed Protection Area. In general, the OSS are located more than 300 feet from public sewer. Neighborhood lift stations are identified on Figure 5.4.

As development continues, the Northeast basin may struggle to extend public sewer systems. However, successful water resource management will focus on connection of new development to public sewer as well the conversion of OSS.

5.4 Southeast Watershed Basin

Like the Kettles basin, the Southeast basin will support appreciable development activity in Olympia over the next 20 years (Figure 5.5). Peak flows in this basin are expected to increase by 85 percent over that period. Planning for these flows is important to the orderly operation of the Utility.

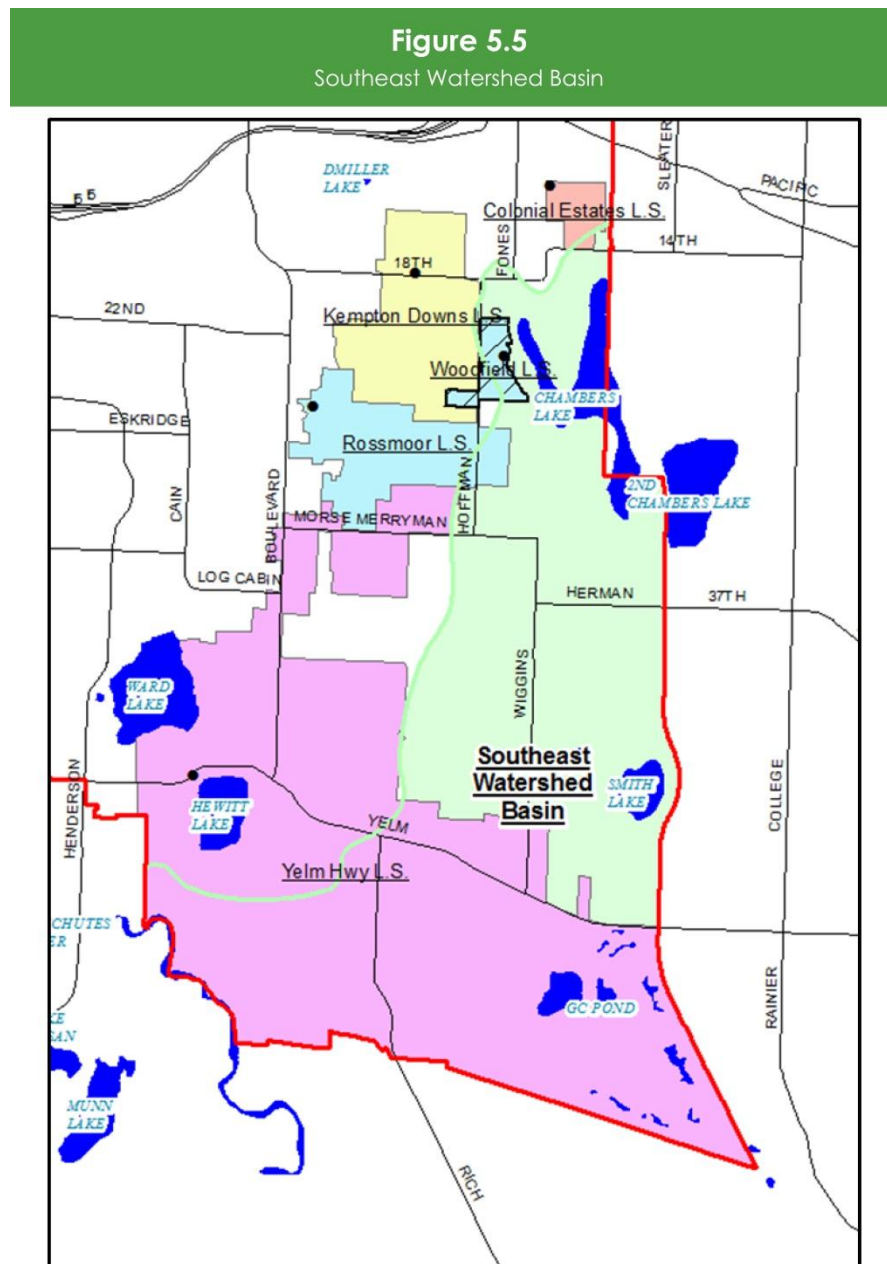

This basin, characterized by its flat topography, has been the focus of considerable STEP system development since the mid-1990s. Additionally, many of the older residences in this basin are served by OSS. There are 705 STEP systems and 1,010 OSS in the basin. OSS are typically distant from the gravity flow portion of the wastewater collection system.

Stormwater and surface water in the Southeast basin discharge to the Deschutes River and ultimately Budd Inlet. Water bodies include portions of Chambers Lake and Chambers Creek, which discharges into the Deschutes River. The river is a major contributor of flows and potentially contaminants to Budd Inlet. The basin's topography requires several lift stations in order to serve the entire area with gravity sewers. Ongoing new development in the basin prompts the need for carefully managed sewer extensions coordinated with the Kettles basin. The LOTT Clean Water Alliance may build a satellite treatment plant in southern Lacey off College Street (Chambers Prairie). In order to maximize flow diversion from the Budd Inlet Treatment Plant, the satellite plant would draw from southern Lacey and the Southeast basin. Coordination between Olympia, Lacey and LOTT is critical as development continues in this basin.

5.5 Southwest Watershed Basin

The Southwest basin (Figure 5.6) includes older neighborhoods of West Olympia and most of the Westside commercial district. With both redevelopment and new development forecast for this basin, sewer flows in the basin will increase.

Surface water flows in the Southwest basin discharge to the Black Lake Ditch, Percival Creek, Capital Lake, and finally Budd Inlet. The Percival Creek system is the City's largest stream and the most viable for salmon life cycle needs. Bacteria levels in the stream are typically low, potentially reflecting an extensive sewer system and a low number of OSS (41) in the basin.

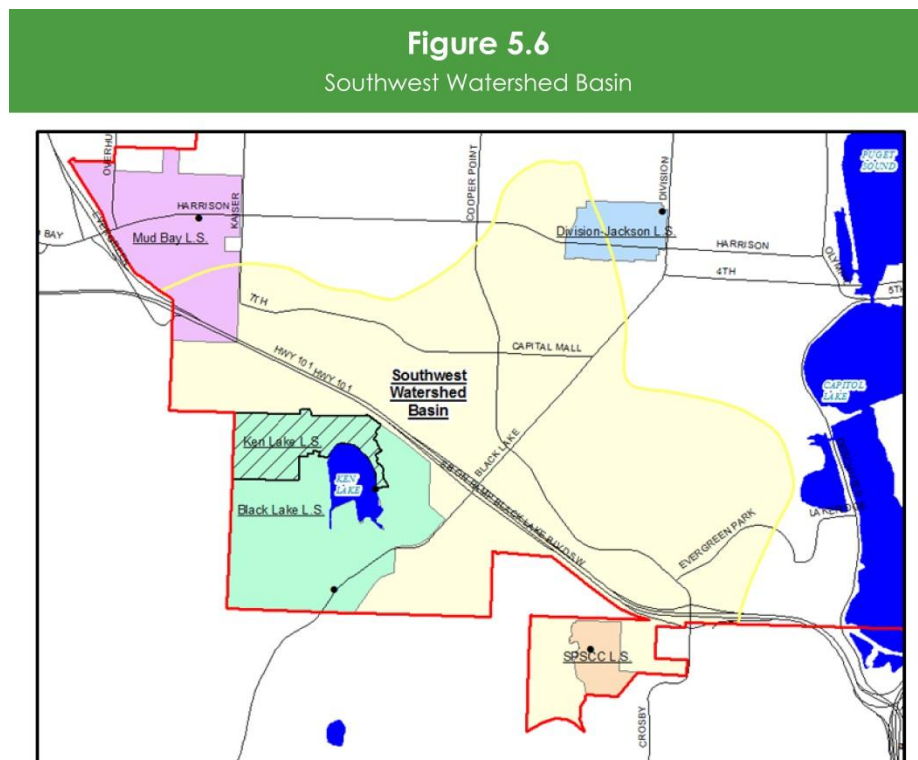

Older sewer systems dominate the residential neighborhoods of West Olympia. Conversely, the commercial and multifamily areas are typically served by newer pipe systems. The suitable topography of the basin supports extensive use of gravity pipe systems. The public sewer system in the basin is generally able to accommodate growth.

Future wastewater management will focus on maintaining the older residential wastewater collection infrastructure and ensuring the orderly extension of new sewer facilities.

5.6 Northwest Watershed Basin

The Northwest basin (Figure 5.7) has received considerable residential development in the past several decades. It is characterized by new development activity along Cooper Point Road and Mud Bay Road.

The surface and groundwater flows from the basin discharge to Green Cove Creek and other tributaries to Eld Inlet. The relatively high water quality of Eld Inlet warrants continued protection as urban scale development extends to the west of Olympia. In order to help protect its aquatic resources, the City has enacted special zoning and development requirements for the Green Cove basin.

Figure 5.7

Northwest Watershed Basin

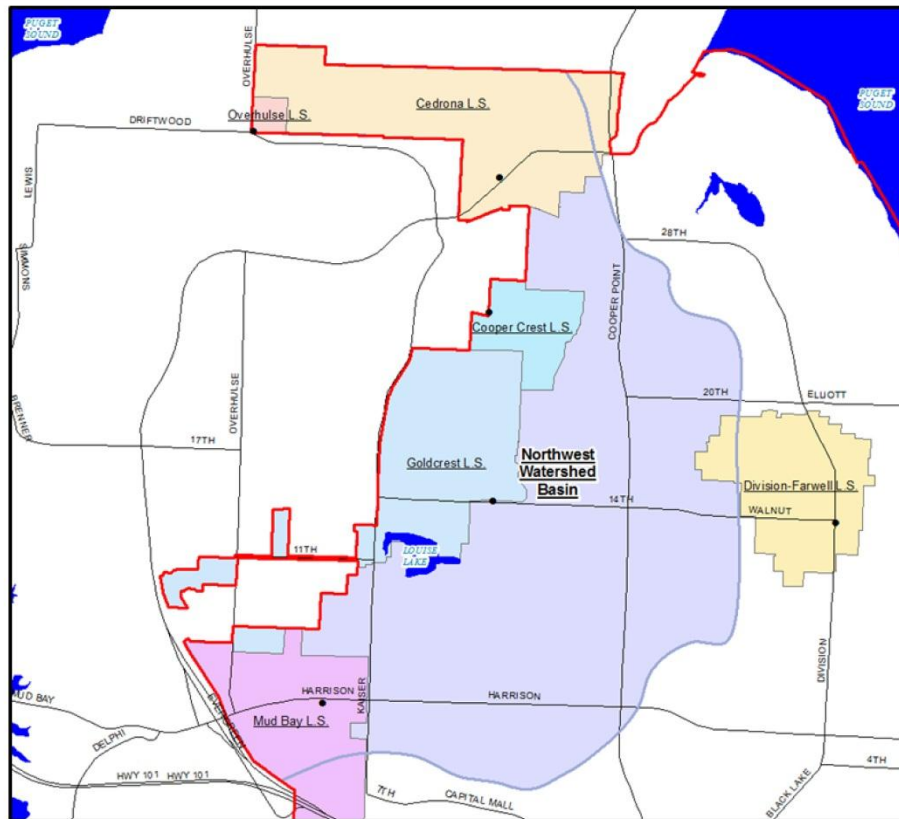

Sewer expansion in this area will be driven by development. Existing sewers in this basin feed into the LOTT-owned Grass Lake and Percival Creek interceptors, which flow to LOTT's Capitol Lake Pump Station. Peak flow in this basin is expected to increase 59 percent by 2025. Development is likely to be dominated by residential subdivisions.

The basin includes 116 STEP systems, clustered along 11th Avenue NW, and 305 OSS, mainly located in the area surrounding Lake Louise and to the north along Cooper Point Road. Key challenges for this basin focus on providing sewer extensions to the low-lying areas.

Careful planning and implementation of sewer extensions is necessary for preserving the health of this basin.



Management Programs

Chapter 6

In this chapter we describe the Wastewater Utility’s role and relationships within the Public Works Department and the overall City structure, our staff structure, and the six core services that we manage.

6.1 Organizational Relationships

Olympia’s Public Works Department is organized into four lines of business: Water Resources, Waste ReSources, Technical Services and Transportation. The three water-related Utilities (Drinking Water, Wastewater, and Storm & Surface Water) are managed under the leadership of Water Resources (see Figure 6.1 below). The Reclaimed Water Program is part of the Drinking Water Utility.

Figure 6.1
Organizational Relationships

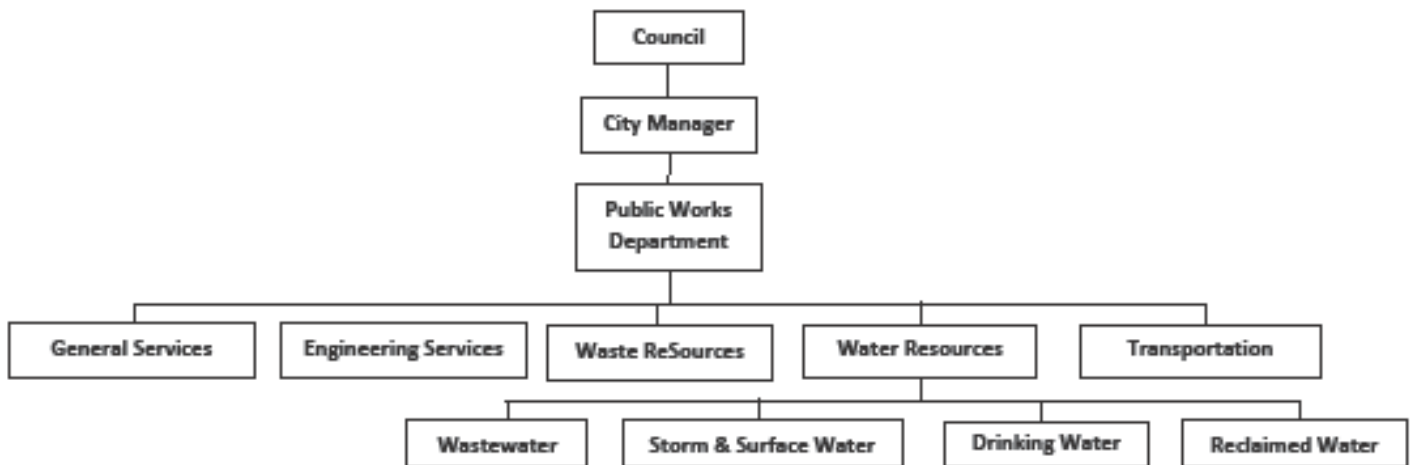

Technical Services supports Water Resources and the other lines of business by providing capital facilities engineering, design and construction management.

The Wastewater Utility is also supported by other City departments including:

- General Government - Oversight of City policies and legal issues as well as coordination of emerging issues.
- Administrative Services - Billing, payroll, financial planning and cash management.
- Community Planning and Development (CP&D) - Implementation of development regulations and long-range community planning.

Like other City utilities, the Wastewater Utility is responsible for its share of the City's overhead expenses. These include a portion of the costs of Public Works administration and other City departments (e.g. City manager, legal and administrative services; computer and telephone networks; building rental, vehicles, insurance, maintenance and janitorial services).

6.2 Staff and Core Services

Staffing

Each of the utilities provide a broad range of services employing diversely skilled workers. The keys to the success of the Wastewater Utility is both effective operation and maintenance of the wastewater infrastructure, and broad range planning, engineering and implementation services.

Given the relatively small size of the City, water-related Utility staff often share operation and maintenance responsibilities as needed. Additionally, the technical office staff of the Storm & Surface Water Utility and Wastewater Utility coordinate and share expertise.

The operation and maintenance of wastewater infrastructure, including lift stations, relies upon 10.2 full-time equivalent staff positions (FTEs). These staff serve the infrastructure. Typical duties include pipe televising and cleaning, pipe repairs, STEPs system and lift station maintenance, and emergency response. Chapter 7 is dedicated to a detailed discussion of operation and maintenance work and needs. Additionally, the Wastewater Utility employs 2.25 (FTEs) dedicated to planning, engineering and implementation: 0.5 FTE for the Engineering & Planning Manager, and 1.75 FTEs for two Water Resources Engineers. These staff members evaluate the wastewater infrastructure and support the overall wastewater program. They are responsible for the various Utility core services, except Operations and Maintenance, described below.

Core Services

Re-structuring the Wastewater Utility was one of the primary efforts of the 2007 Wastewater Management Plan. Since the adoption of that plan by City Council, the Plan's strategies, objectives and actions have been implemented through the six core services described below.

The intent of this 2013 Plan is to continue using the six core services to implement the Strategies outlined in Chapter 9, providing a comprehensive wastewater program integrated with other City water-related work efforts.

The core services are:

1. Planning, Policy and Program Management (PPPM). Planning for long term needs, developing policies, managing programs and information, and annual budgeting.

2. Capital Facilities Program (CFP). Planning, scoping, budgeting, tracking and monitoring construction of public infrastructure projects.
3. Operation and Maintenance (O&M). Maintaining sewer pipes, lift stations, septic tank effluent pump (STEP) systems and community onsite sewage systems; conducting ongoing condition assessments of pipelines; responding to sewer overflows and other emergencies; and constructing small-scale repair projects.
4. Development Review, Code Enforcement and Technical Assistance (DR/CE/TA). Implementing wastewater regulations for new and existing private development; giving technical support to staff, customers and developers.
5. Monitoring, Research and Evaluation (MRE). Tracking environmental health implications of wastewater management. Ensuring that the program incorporates new technologies as they become available.
6. Public Involvement and Education (PIE). Involving and educating customers and the community on water resource issues such as conserving and reusing water, converting onsite sewage systems to public sewer conversion, finances and reducing solid waste.

Figure 6.2 illustrates how these core services function in concert. Along with O&M, PPPM develops and manages plans, policies and programs, in response to City policies, State/federal regulations and identified system needs. These are implemented by CFP and O&M (public infrastructure), DR/CT/TA (private infrastructure and customers), and PIE (citizens and businesses). The results in terms of program effectiveness are monitored by MRE, which feeds evaluative information back to O&M and PPPM for use in modifying policies or programs.

Figure 6.2

Relationships between Wastewater Utility Core Services

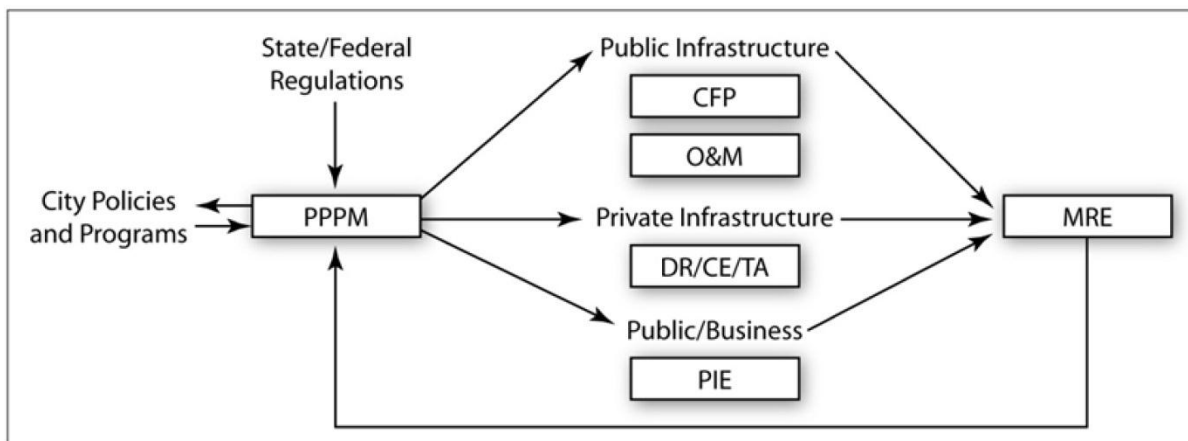

Wastewater Program Outcomes

Implementation of this Plan's Goals, Objectives and Strategies will provide a comprehensive wastewater program integrated with other City water-related work efforts.

Specifically, the program will be able to:

- Proactively understand, plan for and construct needed infrastructure.
- Operate and maintain the infrastructure so that public and environmental health is protected.
- Coordinate water quality improvement efforts with others involved in surface and groundwater management.
- Provide technical assistance to residents interested in converting from OSS to public sewer service.
- Plan for and manage sewer service in support of both new development and re-development.
- Manage utility funds responsibly and equitably.
- Respond to emerging issues.
- Communicate effectively with the community.

The following sections of this chapter describe each core service in more detail, including typical actions. Staff of the core services work together to address the Objectives identified in Chapter 9.

6.3 Planning, Policy and Program Management

Planning, Policy and Program Management helps coordinate the services of the Wastewater Utility. This core service supports all Wastewater Utility services, consistent with the City and Utility goals and strategies. We provide analysis and technical support to develop and employ best practices in wastewater management policies and programs. The work assists Operations and Maintenance in short and long work efforts.

Much of our work focuses on resolving a conflict or issue sustainably, i.e. taking into account the protection of public and environmental health while minimizing financial impacts to individuals, developers and rate payers. This is an essential aspect of integrated water resource planning and engineering, particularly in an increasingly urban setting.

Typical actions are:

1. Manage implementation of the Wastewater Management Plan. We help keep program core services oriented towards overall City goals and policies.
2. Analyze existing policies and potential revisions, interpret regulations and help implement necessary changes. Wastewater policies and associated regulations are often complex and challenging to implement on a case-by-case basis. The financial interests of individual property owners, developers and the City can conflict as the challenges of collecting and conveying wastewater from increasingly outlying areas to LOTT regional facilities become more demanding.
3. Provide policy and technical resources to manage emerging issues and needs.
4. Maintain staff relationships with LOTT and neighboring jurisdictions in order to address common issues such as shared water quality challenges in overlapping watersheds, planning for emergency response, providing sewer service to areas not currently served, budgeting/rate setting, and long-range planning.

6.4 Capital Facilities Planning

Capital facilities are publicly-funded construction projects that meet a community need, such as safely conveying wastewater from homes and businesses to treatment facilities. Our capital facilities planning is based on a thorough understanding of the function and condition of existing infrastructure, and includes forecasting future needs and responding to unanticipated problems.

Typical capital projects are repair or construction of gravity sewers, lift stations and pressurized sewer and STEP pipes. Capital projects are financed through utility rates, general facilities charges (GFCs) paid by new development for connecting to and utilizing existing City wastewater systems, bonds and loans. See Chapter 10 for more information regarding the development of the Capital Facilities Plan for the Wastewater Utility.

6.5 Operations and Maintenance

The Wastewater Utility's Operations and Maintenance services are familiar to many people who see crews at work cleaning, televising and maintaining sewer pipes and facilities. Our field crews maintain, repair and upgrade the City's extensive wastewater infrastructure to prevent spills and repair leaks.

Operations and maintenance is important to the infrastructure-dependent Wastewater Utility, accounting for over 60% of the utility's budget in 2012. Chapter 7 provides detailed information regarding this core service, including typical actions and emerging needs.

6.6 Development Review, Technical Assistance and Code Enforcement

While the Capital Facilities and Operations and Maintenance core services are responsible for the existing public wastewater infrastructure, this core service focuses on the review of new wastewater facilities that will connect to and/or become public facilities, technical assistance for existing systems on private property, and actions on violations.

Typical actions are:

1. Review proposed new wastewater infrastructure. We work with property owners and developers during plan review to ensure compliance with local and State wastewater regulations, and provide technical support to the City's Community Planning and Development Department (CP&D) permitting and inspection processes. Our focus is on managing wastewater flows in accordance with long-term system goals for utilizing existing pipe capacity, minimizing lift stations, and increasing the potential to serve areas of infill and onsite sewage systems.
2. Provide technical assistance to wastewater customers. As wastewater concerns and regulations become more complex and demanding, more customers request assistance from the City. We assist with such issues as replacing sewer laterals, converting from OSS to public sewer service, controlling odors, maintaining STEP systems and managing onsite systems. Resolving concerns from the development community and residents requires detailed knowledge about the sewer collection system.
3. Enforce illicit discharge and pretreatment regulations. Illicit discharges to the public sewer systems degrade water quality, expose the public to potential public health threats, increase maintenance needs, impact LOTT Alliance treatment facility performance, and may violate stormwater permit requirements. For example, the discharge of fats, oils and grease from food establishments clogs downstream pipes, increasing the need for routine maintenance and emergency response.

4. Provide GIS support. Supported by the City's Information Technology group, our staff manages and supports digital information related to the Wastewater Utility, for use by various planning, CP&D and O&M staff.

6.7 Monitoring, Research and Evaluation

This core service helps accumulate and analyze information needed to plan, implement and evaluate the effectiveness of the Wastewater Utility, and keep Olympia up to date with current and emerging wastewater technology. It also helps integrate wastewater practices with other water resources responsibilities such as protecting water quality.

Typical actions are:

1. Provide resources for wastewater-related surface and groundwater monitoring. Unintended discharges from public sewers and onsite sewage systems are often diluted and intermittent, yet capable of closing shellfish beds, violating surface water standards and making groundwater undrinkable. Monitoring and isolating problems is often time consuming. As needed, our staff supplements existing City environmental monitoring programs, especially the Groundwater Protection Program and the Stormwater Ambient Monitoring Program.
2. Develop and maintain information systems for onsite sewage system (OSS) management. This includes maintaining a database of OSS locations and tracking failures, inspections, certifications and hookups. We coordinate this information with Thurston County records and reporting systems.
4. Explore and evaluate new and innovative wastewater technology. We actively pursue potential new technologies that can enhance our ability to provide sewer service to our customers, determine the feasibility and cost-effectiveness of the technology, and make recommendations for its application in Olympia.

6.8 Public Involvement and Education

Public and environmental health requires a participatory and responsible community. Public involvement and education activities are supported by the City of Olympia as an essential service of resource management programs.

Typical actions:

1. Support implementation of Plan priorities, particularly incentives options available for conversion to public sewer. This includes informing OSS owners and infill lot owners of incentives and opportunities for conversion of existing systems and hookups on infill lots.
2. Keep customers informed about Wastewater Utility activities, regulatory and rate changes. Our primary communication tools are Wastewater Utility bill inserts, media releases and direct mail.
3. Coordinate with regional partners in planning and implementing wastewater educational activities. In past years, the Wastewater Utility has helped fund onsite system maintenance workshops.
4. Informing and involving customers and other stakeholders in wastewater planning activities. In partnership with other utilities, we strive to keep the community informed on water resource and solid waste issues such as conserving and reusing water, reducing solid waste, and converting onsite sewer systems to public sewer. Activities include direct mail to stakeholders, media information, focus groups and workshops.



Wastewater staff is responsible for all day-to-day operations and maintenance (O&M) activities associated with the approximately 224 miles of sanitary sewer pipe ranging from two to 42 inches in diameter; approximately 4,000 manholes and 1,000 cleanouts; 33 sewer lift stations; over 1,860 residential, commercial and multi-family STEP systems; and one community onsite sewage system. This chapter discusses O&M staff organization, and O&M activities: routine and preventive maintenance, computerized maintenance management, small scale repair projects, emergency response, and training. Emerging trends and needs are discussed.

7.1 O&M Staff Organization

Wastewater system O&M staff draws from two work groups in the Public Works Department. Wastewater/Stormwater Operations staff operates and maintains both sanitary sewer and stormwater collection systems (including gravity sanitary sewers; force mains; catch basins and manholes; STEP tanks, mains and service lines; and community onsite systems). Additionally, a pump crew supervised by Pump Stations Operations maintains all wastewater lift stations. Allocating staff time based on similar kinds of work and required skills across the Utilities has proven effective in making the most of limited resources. Cost and funding is managed separately for the various work efforts.

The Wastewater Utility funds 11.2 FTEs for the operation and maintenance activities listed below. Some employees are partially funded and used by the Stormwater and/or Water Utilities thereby making a full position.

- Wastewater/Stormwater Operations Supervisor (0.5 FTE).
- Pump Stations Supervisor (0.5 FTE)
- Wastewater /Stormwater Lead Worker (0.5 FTE).
- Data Control Specialist (0.375 FTE).
- Maintenance Worker II (5.5 FTE). Four and a half employees are assigned to work on pipe cleaning and TV inspection and one employee on STEP systems.
- Maintenance Worker I (0.5 FTE).
- Utility and Pipe Locator (0.33 FTE).

- Maintenance Technician (2 FTE), assigned to wastewater lift station O&M.
- Remote Systems Technician (1 FTE), assigned to operation and maintenance of the wastewater telemetry system, as well as controls and electrical equipment.

7.2 Routine and Preventative Maintenance

The operations staff maintains the wastewater system on a daily basis through a system of both scheduled work and response to priority problems. Distinct activities address the needs of gravity sewer lines, lift stations, STEP systems and community onsite septic systems. Taken as a whole, these activities are essential to minimizing threats to public and environmental health.

Gravity Sewer Lines

Operation and maintenance of the many gravity sewer pipes ensures efficient and unobstructed sewer flows, since neglect can lead to overflows. Pipes are susceptible to accumulation of sludge, soil and debris. Roots commonly force their way into cracks in pipes and must be removed.

Cleaning underground pipes requires specialized truck-mounted equipment (vactor truck) capable of water jetting pipes and retrieving the materials. The wastewater vactor truck often works in conjunction with the pipe televising van to both clean and inspect the pipes.

On an annual basis, the maintenance of gravity sewer lines entails:

- Routine cleaning of approximately 200,000 feet of gravity pipes.
- Televising approximately 160,000 feet of pipe.
- Removing roots in 30,000 feet of pipe.
- Cleaning 27,000 feet of problematic pipes, mainly due to low flow, flat slope, and/or grease.
- Responding to approximately 200 unanticipated problems/call-outs.

Additionally, the operations crew responds to emergencies such as pipe breaks and sewer overflows. These responses take priority over scheduled maintenance and often interfere with ongoing productivity and efficiency. Responses are often after hours.

Efforts are ongoing to improve efficiencies and effectiveness of operations work. Typical work is coordinated between office and field staff and includes:

- Improving mapping of the pipe systems as well as the availability of online maps in the field.
- Managing work orders through our asset management software in order to better understand the time and resources expended on specific types of work and individual system components.

- Prioritizing work in high maintenance and highly vulnerable areas.
- Incorporating new technologies.
- Developing problem solving teams to track and address reoccurring problems.

Other activities such as small-scale projects to repair or replace pipes and manholes, as well as television inspection and condition rating of gravity sewer lines are described in separate sections below.

As the City's pipe system grows, these maintenance needs and the personnel needed to perform them will increase. This Plan projects the needs to increase operations and maintenance staff in the long-term.

Lift Stations

Lift (pump) stations and force (pressure) mains are used to convey wastewater from a low point in the collection system to a higher elevation from which it can continue flowing by gravity. The City currently owns and operates 30 lift stations, and operates three privately-owned lift stations through contractual arrangements. Failure of any of the critical lift station components can lead to significant, ongoing wastewater overflows.

Electronic telemetry, also known as Supervisory Control and Data Acquisition (SCADA) equipment, monitors operations continuously at each lift station and signals any malfunction to the SCADA communications center at the City's Maintenance Center. A telemetry failure prompts an immediate response by O&M personnel. The number of wastewater lift stations in concert with the extensive drinking water pumping system necessitates effective telemetric monitoring of the stations.

The Pump Stations crew checks each lift station monthly to verify proper operation and ensure emergency preparedness. The crew also completes many mechanical and electrical improvements to the stations including:

- Pump replacements
- Emergency generator installations
- Monitoring upgrades
- Site and building maintenance

Over the course of the past seven years, 14 of the 33 existing lift stations have been upgraded in one form or another. These improvements are essential to providing sewer service without serious system failures. This Plan will ensure that lift station upgrades are proactive rather than in reaction to failures.

As Olympia grows, especially in outlying areas, the use and number of lift stations increases. Pump crew staffing will also need to increase.

STEP Systems

The City owns and operates 1,860 STEP systems located on individual privately- owned parcels (for details see Chapter 3), including 20 commercial and multifamily systems. STEP systems serve approximately 12 percent of the Utility's residential sewer customers.

Maintenance of these systems is labor intensive. Systems are typically located near the street within the yards of individual residences. All systems are inspected every one to two years, depending on size and complexity. Residential STEP systems are scheduled for maintenance and removal of solids once every seven years and commercial STEPS every one to four years, depending on size and use. Regular maintenance includes pumping the tank and removal and cleaning of screens, pumps and level controls. Maintenance of STEP systems requires one dedicated staff person as well as contractor services for tank pumping.

Operational problems with individual STEP systems can result in overflows. With this in mind, a system failure prompts the resident to notify wastewater staff. In turn, staff inspects and repairs the system, often after normal work hours. Given the high number of systems in the City, a relatively high level of maintenance is needed to minimize time-consuming and costly emergency responses. Significant strides have been made in recent years to bring maintenance and emergency responses down to manageable levels.

COSS Systems

At one time, Olympia owned and operated three community onsite sewage systems (COSS). Two of them have recently been abandoned in place and are now connected to the public sewer collection system. Regular maintenance of the remaining system on Devoe Street in the northeast UGA is similar to that of commercial STEP systems, with the tanks being pumped once every two years. From a maintenance perspective, the installation of new COSS is discouraged. Maintenance of the remaining one COSS is manageable.

Services Provided to LOTT

Under the 2000 intergovernmental agreement establishing the LOTT Clean Water Alliance, Olympia can be called upon to provide certain services to maintain the regional LOTT wastewater management facilities. These services vary from year to year and can include cleaning of the dump basin used by onsite system service firms and the centrate line at the Budd Inlet treatment plant. LOTT reimburses the City for these services.

At a minimum, services provided to LOTT include availability of staff and/or equipment during potential emergencies. Executed in 2012, a Mutual Aid Agreement between the four local jurisdictions and LOTT is now in place for coordinated and joint emergency response.

7.3 Asset Management and Condition Rating

The 2007 Wastewater Management Plan emphasized the need to develop and implement systematic asset management including computerized maintenance management and condition rating for gravity sewer lines. Software programs are being used by both O&M and Wastewater Planning staff in order to track the status and needs of the extensive infrastructure system. More work in this area of operations and maintenance is needed.

Computerized Maintenance Management System

Computerized systems facilitate the tracking of infrastructure condition, operational needs, and completed maintenance. Individual components of the overall system including pipe sections and manholes are tracked. Our computerized maintenance management system (CMMS) uses VUEworks software, installed in 2011. It reduces system-wide maintenance in favor of site-specific maintenance designed to meet the needs of the specific component. With this system, high maintenance components are serviced frequently; low maintenance ones less frequently. Service requests are submitted in VUEworks and work orders are generated and tracked by location using GIS. Equipment inventory is also managed by CMMS.

Field crews use the system for up-to-date, detailed information on infrastructure components as they work. Having field access to GIS technology allows them to efficiently retrieve comprehensive information about the infrastructure.

Improving asset management will continue to be an ongoing priority of the wastewater program.

Televising and Condition Rating

O&M crews and engineering staff use television inspection and condition rating of gravity sewer mains to evaluate structural integrity and identify O&M and construction features. The ability to see the underground pipe systems is essential to effective management.

The televising system gives staff the ability to look at pipes and document their design and intricacies. The distance that the underground camera travels is recorded, allowing staff to locate pipe features and problem areas. Using industry standards, the structural condition of the pipe can be assessed and documented. With repeated televising, changes in the condition of a pipe over time are tracked.

The televising and condition rating program provides staff with a list of priority repairs. Some of the repairs are small and can be corrected by City construction staff. Others evolve into extensive design and construction projects. Regardless of the project's scale, the condition rating program catches problems and facilitates their timely correction.

The program is implemented by a one-person television inspection van equipped with the industry standard Pipeline Assessment Certification Program coding and Granite XP

software, installed in 2008. Wastewater planning and implementation staff manage the condition rating information and initiate, schedule and prioritize most minor and major repairs.

Since 2005, approximately 900,000 feet (21 miles) of sewer pipe has been televised and condition rated. Work continues, with initial inspection of the entire system expected to be complete in 2014. Potential problem areas will be re-televised on a regular schedule.

As televising and condition rating needs for the gravity pipe system decline after 2014, the integrity of other components of the wastewater infrastructure may warrant inspection and tracking. Manholes, force mains, and lift stations would all benefit from ongoing asset management tracking. The location and condition of private systems such as the lateral pipes connecting homes to the gravity system in the street are largely unknown. We can anticipate the future need for a better understanding of these systems. The level of staff and equipment dedicated to televising and condition rating needs to be maintained and potentially expanded.

7.4 Small Scale Repair Projects

The capacity of the Wastewater Utility to routinely construct small-scale wastewater systems repairs and upgrades has greatly increased since 2007. Instead of relying upon private contractors, in-house staff and necessary construction equipment are available. This construction ability is effective and cost efficient.

Typical annual in-house repairs include the following:

- Approximately 70 pipe repairs
- 5-10 manhole repairs, replacements or new installations
- In the last two years, 2-4 sanitary cross connections with stormwater infrastructure have been disconnected or otherwise eliminated.

Work in this arena will continue and potentially grow as the condition rating program identifies needed pipe repairs.

7.5 Emergency Response and Mutual Aid

In September 2012, Olympia and the other LOTT partners signed an Interlocal Agreement for Sanitary Sewer Emergency Response Mutual Aid, to enable mutual assistance in the event of a sewer overflow involving assets owned by either LOTT or member jurisdictions.

In 2013, the City updated its Emergency Response Plan (see Appendix I), documenting procedures the City follows to protect public and environmental health and safety during a sewer overflow or other emergency event. It describes the roles and responsibilities for managing various types of emergencies, and details general procedures that are

followed during and after an emergency situation. The plan parallels LOTT's emergency response plan, and includes cooperative arrangements with LOTT and neighboring cities.

7.6 Training and Certifications

Staff certification and training programs are in place, consistent with Washington State Wastewater Collection Personnel Association recommendations. Our goal is to have all sewer operations staff trained and certified at the Wastewater Collection Specialist I level; the Operations Supervisor will be trained at the Specialist II level.



Long Term Challenges

Chapter 8

In Chapter 1, we stated the Wastewater Utility's mission and how it relates to the City's overall Comprehensive Plan. While the Comprehensive Plan is being updated in 2013 concurrently with this Plan, we anticipate that the final version will include a goal substantively the same as its draft Goal GU2, which states (as of March 2013):

Reliable [utility] service is provided at the lowest reasonable cost, consistent with the City's aims of environmental stewardship, social equity, economic development and the protection of public health.

We face numerous challenges in providing wastewater service having these qualities. At the time of the 2007 Wastewater Management Plan, we identified four key challenges: (1) limiting new onsite sewage systems, (2) converting onsite systems to the City's sewer system, (3) prioritizing/funding sewer extensions into unsewered areas, and (4) maintaining and upgrading existing infrastructure. Since 2007, we have taken major steps to address these four challenges; however, they along with others remain to be addressed in this and future Wastewater Utility plans.

This chapter discusses the following nine challenges that the Wastewater Utility now faces and will continue to face in the foreseeable future:

1. Existing Infrastructure
2. Onsite Sewage Systems
3. Extending Sewers to New Development
4. Sea Level Rise
5. Use of Drinking Water Resources
6. Use of Energy Resources
7. LOTT/City Coordination
8. Equitable and Predictable Rates and Fees
9. Public Education and Involvement

These challenges provide a segue to Chapter 9, which details how we intend to respond to these Challenges through the Goals, Objectives and Strategies that are the focus of this Plan.

8.1 Existing Infrastructure

Ageing and maintenance-intensive infrastructure poses risks to public health and water quality.

The most prevalent sources of risk relating to this Challenge are described below. They are:

- Deteriorating mains and manholes
- Infiltration and inflow
- Lift stations
- STEP systems
- Illicit sewer connections in the stormwater system

Deteriorating Mains and Manholes

Olympia's collection system includes about 185 miles of gravity sewer pipes and over 4,000 manholes. More than 50% (by total length) of Olympia's sewer mains are more than 40 years old and made of either concrete or vitreous clay pipe. These types of pipe are most susceptible to structural issues such as cracking/breaking and corrosion, which leads to infiltration of groundwater and/or eventual pipe failure if not corrected.

Aging brick and concrete manholes are also susceptible to corrosion and structural failure unless repaired or replaced in a timely manner.

Given the extensive and aging wastewater system, understanding the operational and structural integrity of pipes and manholes is critical to environmental stewardship and public health as well as long-term financial planning. Effective operation and maintenance of these systems is essential. Understanding the systems through asset management techniques is necessary for improved cost effectiveness.

The wastewater condition rating program, set up in 2007 to identify and characterize both structural and operational deficiencies of all gravity sewer pipelines in the system, is approaching the end of its first round of inspections. Under the program, pipes are televised and assigned a numeric value corresponding to their condition and potential life expectancy.

Structural and operational deficiencies identified are either corrected by City maintenance activities or capital facility projects, preferably using trenchless technologies. Re-inspections are based on criteria for pipe condition and criticality to the overall system. Completion of the first round of pipe inspections is an important accomplishment of the wastewater program.

In future years, condition rating will continue for pipes according to their current condition and criticality. The older and/or more critical a pipe is, the more frequent will a video inspection occur. This condition rating system supports the identification of pipes needing repairs or replacement. In doing so, the rating system will help determine financial and resource needs.

Infiltration and Inflow

In areas with high groundwater, as well as during winter weather conditions, groundwater (infiltration) and stormwater (inflow) can enter wastewater pipes through joints, cracks and direct connections. Older pipes made of vitreous clay and concrete (mainly installed prior to 1960) are especially susceptible to infiltration. Infiltration and inflow can be substantial, effectively reducing

the capacity of the pipes to convey wastewater. Sewer overflows and back-up can result. LOTT wastewater treatment facility capacity is also adversely impacted.

There are a variety of infiltration and inflow (I&I) sources, as illustrated in Figure 8.1:

- Designed inflow from storm drains into combined sewers, which carry both sanitary sewage and stormwater.
- Planned (or illegally connected) inflow from storm drains (e.g., in a parking lot), roof or foundation drains, and other sources connected to a sanitary sewer. In Olympia’s older neighborhoods many residential roof downspouts and/or basement sump pumps are piped directly into the wastewater system.
- Infiltration of groundwater into leaky sewer pipes and manholes when the groundwater level is above the pipe.

Figure 8.1
Sources of Inflow and Infiltration

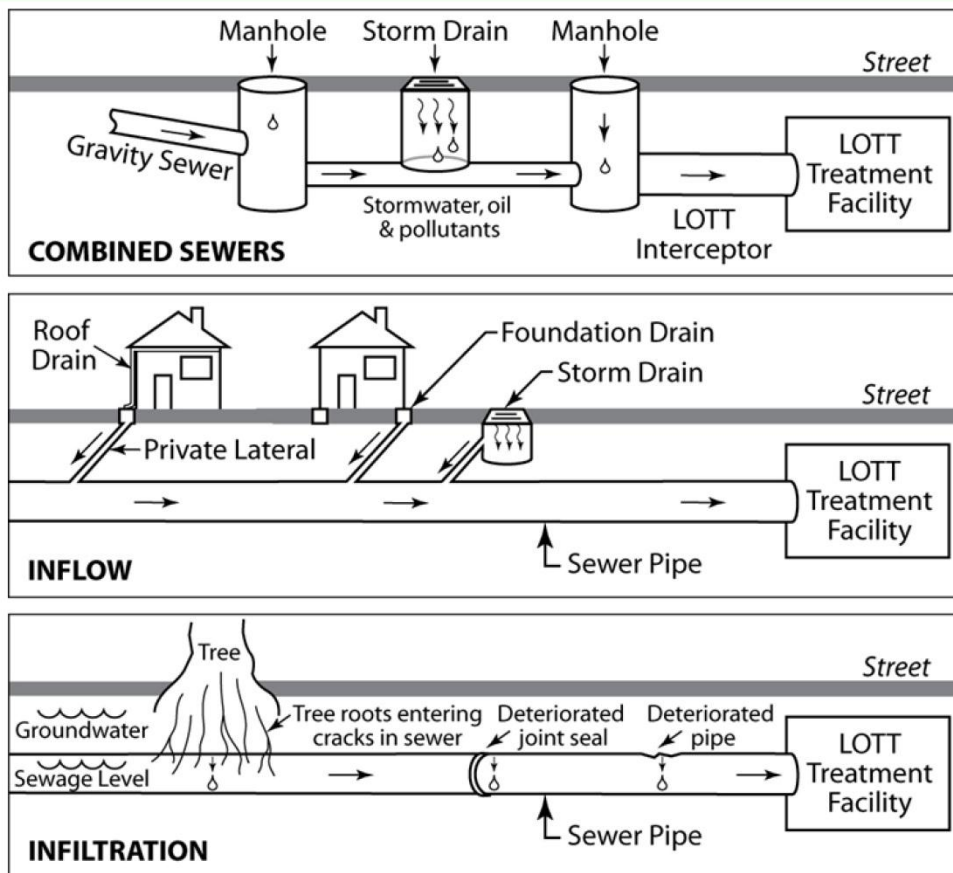

There are four main areas of Olympia that are susceptible to I&I:

- The westerly slopes of West Bay.
- The central business district, Capitol Campus and South Capitol Neighborhood.
- The plateau south of San Francisco Avenue and west of Puget Street in northeast Olympia.
- The Ken Lake area.

While there have been several projects to separate I&I from the sewer system in these areas, the efforts have been limited. This is due to several factors, including:

- Cost of separating the sewers
- Difficulty of separating sewers on private property
- Need to procure a new, permitted outfall for stormwater release
- Need to provide adequate stormwater treatment

So far, our emphasis has been on replacing leaky sewers along the west slopes of West Bay, the west portion of the central business district, and the area immediately west of Ken Lake. Using the condition rating program, we've also replaced smaller sections of pipeline with I&I issues in many locations throughout the service area. See also Appendix N for more information.

Lift Stations

The Utility owns 30 lift stations and operates three others owned by St. Peter's/Providence Hospital, South Puget Sound Community College, and the Cooper Glen Apartments in the Overhulse Drive area adjacent to The Evergreen State College campus. Associated with these lift stations are 8.5 miles of force mains, ranging from 4-30 inches in diameter.

Although the Utility has a robust capital facility program to replace older lift stations, seven more than 30 years old have not been replaced or upgraded, and some force mains are older than that. Concerns regarding structural integrity and capacity of these older lift stations and force mains are similar to those described above. Failure of a lift station to operate as designed, or the absence of a generator during a prolonged power failure, will likely result in a sewer overflow.

Asset management goals and strategies of the Plan also address the condition of existing lift stations using similar criteria as the wastewater condition rating program described above. Repairs and/or replacement of elements of these lift stations, including the installation of an onsite generator at those locations without one, are scheduled as part of the capital facilities program described in Chapter 10.

STEP Systems

Because STEP systems operate anaerobically, the decay of solids in underground STEP tanks releases ammonia and hydrogen sulfide, which has an unpleasant "rotten egg" smell when exposed to the air in downstream gravity sections of the collection system. Additionally, when a STEP pipe discharges into a manhole or gravity pipeline, turbulent flows aerate the effluent, converting the hydrogen sulfide into sulfuric acid. The acid is highly corrosive to the concrete and metal in downstream pipes and manholes.

While past capital projects have installed protective coatings in some discharge manholes and downstream concrete pipes to address the corrosion problem, localized odor problems from hydrogen sulfide continue. As long as there are STEP systems in service, odor and corrosion challenges will be associated with them.

Non-mechanical aerators and/or chemical filters may be necessary to neutralize odor as the effluent is discharged into the sewer system. In the southeast basin of Olympia, costly odor control equipment with chemical feed pumps has been installed to address both odor and corrosion due to STEP effluent discharges into gravity sewer mains.

Illicit Sewer Connections in the Stormwater System

Pollution occurs when sewage is discharged into the stormwater system and then into streams and other receiving waters. The two main concerns are bacteria, and the nitrates produced by sewage that can increase plant growth and reduce dissolved oxygen levels. Within our Sewer Service Area wastewater pipes may unknowingly be connected to stormwater pipes that lead to receiving waters. Over the past 10 years, our emphasis on identifying and correcting these illicit discharges has resulted in decreasing concentrations of bacteria in local streams. However, efforts to identify and correct remaining illicit connections will continue. Ongoing water quality sampling of receiving waters and video inspections of stormwater infrastructure will lead to further investigation and removal of these types of illicit connections.

8.2 Onsite Sewage Systems

Large numbers of onsite sewage systems (OSS) in urban areas threaten water quality and public health, particularly in northeast and southeast Olympia.

The presence of approximately 4,150 onsite sewage systems in Olympia and its UGA creates potential long-term risks to environmental and public health from groundwater, surface water and soil contamination. Onsite systems typically have a life expectancy of 25 years, but are often used longer. In an urban setting, they are seen as an interim form of wastewater treatment until municipal sewer service is available.

One environmental impact of onsite systems is the increasing discharge of nitrates to surface and ground waters. Nitrates, a common nitrogen-species generated by onsite sewage systems as waste decomposes, are increasingly observed in groundwater and surface water, including the City's drinking water supply wells in Southeast Olympia. In some cases, the concentration of nitrate threatens the viability of both private and public drinking water supplies. See Chapter 4 for further discussion on the challenges associated with permitting and converting OSS to sewer.

Converting OSS to municipal sewer service helps reduce public health risks and maintain water quality in surface and ground waters. However, the conversion of OSS to municipal sewer is costly, and therefore challenging, for both residents and the Utility.

Existing and new programs to facilitate and fund conversions of OSS to community sewer are discussed in Chapter 9. These include the Septic to Sewer Program, a connection fee payment plan, capital projects to extend sewers into already developed areas, and technical assistance. Coordination with Thurston County on these and other OSS-related activities will continue under this Plan.

A related challenge is extending sewers to serve new development—both undeveloped lots in the City and undeveloped areas of the UGA—fast enough to prevent the installation of yet more onsite sewage systems. While the City does not have an extension program in place for small developments or single-lot infill homes, we intend to address this within the framework of the Objectives identified in Chapter 9.

8.3 Extending Sewers to New Development

Developing in Olympia and its Urban Growth Area requires planning for and financing sewer extensions effectively and equitably.

Municipal sewer service is the preferred method of sewage management in increasingly urban communities such as Olympia. Compared to onsite sewage systems, the various methods of conveying sewage to a regional treatment facility (e.g., gravity pipes, lift stations, STEP systems, grinder pumps) reduce the potential for public and environmental health risks. However, wastewater goals and policies may conflict with other City goals (e.g. promoting infill development) as well as residents' financial interests.

Sewer service relies upon comprehensive and integrated pipe systems. Local topography often creates conditions that require regional lift stations or other pressurized methods of conveyance. Where lift stations are necessary, both construction and maintenance costs are high. To minimize their number, infrastructure planning needs to foresee development patterns and require lift stations in optimum locations.

The development over time of a comprehensive, cost-effective wastewater collection system requires careful and consistent planning and implementation. Coordination between various City departments, developers, and individual property owners is essential. Providing comprehensive sewer service equitably and efficiently will remain a key Utility priority and challenge.

In some cases, the City and/or Wastewater Utility may need to take a more proactive role in financing infrastructure needed to support new development. Two ways we can do this are by establishing developer reimbursement agreements (also known as latecomer fees) or general facility charge waivers for a specific number of new connections. In addition, we provide technical assistance and review projects during several phases of project development.

8.4 Sea Level Rise

Sea level rise poses long-term risks to downtown; early adaptation may facilitate continued reliability and lowest reasonable cost.

The City currently experiences occasional flooding in the downtown area due to extreme high tides. Because of relatively low ground levels in some developed areas of the City, and multiple open stormwater outfalls discharging to Budd Inlet, flooding will become more of a problem as the mean sea level rises. As streets and parking lots flood, water can enter the downtown's combined stormwater and wastewater pipe system. These flood flows could exceed the capacity of the pipes, creating public and environmental health concerns as well as affecting local businesses and the operation of the LOTT treatment facility.

Critical wastewater infrastructure, such as the Water Street lift station located near Percival Landing, needs to be protected from predicted future storm/tidal events. Our Emergency Response

Plan, Asset Management Program and Capital Facilities Plan will need to account for these concerns in short and long term work efforts.

A more focused vulnerability assessment taking into account sea level rise impacts is a strategy identified in Chapter 9 of this plan.

8.5 Use of Drinking Water Resources

Water, particularly drinking water, is a valuable resource that should be conserved, not wasted.

Water is an important resource, and a basic water resource goal is to use it wisely. This is a shared responsibility of the Wastewater, Drinking Water and Reclaimed Water utilities. By reducing consumer demand for water less water must be treated to drinking water standards. Reusing water through separating out the greywater (from sinks and bathtubs) means less drinking water discharged to the wastewater collection system. Likewise, using reclaimed water for non-potable purposes such as irrigation reduces the need to use drinking water.

The amount of water that enters the wastewater collection system directly relates to the capacity, energy use and cost of existing and future downstream conveyance and treatment infrastructure. This has an impact on long-term capital facilities planning for not only the Wastewater Utility, but also the City's Drinking Water Utility and LOTT Clean Water Alliance.

Our intent with this Plan is to implement consumption-based billing for residential wastewater and continue to coordinate with the other water resource utilities and LOTT public education efforts focused on water conservation.

Also, we intend to collaborate with Thurston County to implement standards for greywater reuse. There is growing recognition of the need to encourage and promote the use of greywater as a sustainable building practice, in order to conserve potable water and reduce the cost of wastewater treatment.

8.6 Use of Energy Resources

Conserving energy can help reduce carbon emissions and operational costs.

Lift stations are the primary consumers of energy in the wastewater collection system. Through this Plan we intend to complete an energy audit of the City's lift stations and replace older diesel generators with cleaner, more efficient ones that use less energy and have lower greenhouse gas emissions.

8.7 LOTT/City Coordination

The City and LOTT, including the other LOTT Partners, need to coordinate activities to minimize inefficiencies and duplication.

LOTT and the City are jointly responsible for meeting the requirements of the NPDES discharge permit issued by the Department of Ecology, including reclaimed water and pre-treatment. Pre-treatment education and enforcement related to fats, oils and grease (FOG) and industrial discharges are of particular importance. In addition, the NPDES permit dictates City and LOTT

responses to public and environmental health issues associated with wastewater spills and discharges. A number of regional water quality issues, such as Total Maximum Daily Loads (TMDLs) of pollutants under the Clean Water Act, require a high level of engagement among LOTT and City staff.

Financially, we will continue to participate with LOTT in making the annual process for establishing LOTT capacity development charges and monthly rates billed to Olympia customers a transparent process.

The sewer service areas of the three LOTT municipalities meet and in some places overlap because of topography or historical events. In some cases, the efficiency of both systems may be improved by reconsidering which jurisdiction can or should provide sewer service in a specific area.

In addition, there is a need to identify and coordinate activities common to all of the City's utilities. Common goals between water-related work groups are increasingly apparent. For example, the Wastewater and Storm & Surface Water programs share an interest in improving water quality. Similarly, Wastewater, Drinking Water and Reclaimed Water programs share common interests in water conservation. The Waste ReSources and Wastewater utilities share an interest in compostable solid wastes that are introduced into the wastewater collection system through garbage disposal units under kitchen sinks.

This Plan acknowledges the complexity of these relationships and emphasizes the need to closely coordinate both program activities and long-term capital project planning.

8.8 Equitable and Predictable Rates and Fees

Creating predictability for customers and developers is difficult in a complex environment.

An important element of utility planning is predicting Utility expenditures and maintaining a stable rate structure, including equitable rate structures for both commercial and residential customers. A City priority is ensuring a fair and equitable distribution of utility costs across the customer base. A healthy and stable utility with predictable long-term revenues and expenses supports economic growth and developer investments in the community.

This Plan includes a detailed financial analysis (see Chapter 11) that evaluates current and potential future expenditures. Based on this analysis, necessary utility rates and one-time general facility charges (GFCs) assessed at the time of construction and connection to the City's sewer system are recommended.

The current wastewater rate structure uses volume-based rates for commercial customers, but one flat rate for all residential customers, regardless of the amount of drinking water consumed and subsequent wastewater generated.

This Plan intends to implement a volume-based residential rate structure where users of less drinking water (therefore generators of less wastewater) would be charged lower wastewater rates than users of more water. This billing structure should also help encourage water conservation.

8.9 Public Education and Involvement

Keeping customers and the community involved and informed about challenges, needs, plans and proposals helps ensure that programs and projects are responsive to customer needs and community values.

Wastewater technical and regulatory issues are complex. Resolving various concerns from the development community and both commercial and residential customers requires detailed knowledge about the wastewater infrastructure. Decisions about gravity sewer and STEP system availability and potential extensions, onsite sewage system permitting, and problem troubleshooting are financially important to those effected by wastewater policies. Code enforcement, environmental monitoring and public education on specific issues are also important. Communicating this information often requires detailed site specific interactions with customers.

With the exponential increase in use of electronic media, customer and community expectations are high concerning access to digital information associated with the Utility. Maintaining our capacity to be helpful and responsive is a key service.

Ideally we need more customer involvement in, and understanding of, how their habits and actions affect the environment, particularly as they relate to water resources. Coordination with the LOTT Clean Water Alliance on public education efforts is one strategy identified in this plan. Others include increasing the amount and type of information available through the City's website, and actively approaching the Utility's customer base to determine their concerns.



The Plan is organized around seven Goals, with one to three Objectives identified for each. The Goals respond to the question, “What do we hope to achieve in the long term?” Objectives answer “What will we do to achieve these Goals within a shorter time frame?” Strategies answer the question “How will we go about accomplishing our Objectives?”

These Objectives and Strategies do not encompass the entire range of wastewater responsibilities and day-to-day work. Rather, they focus on the challenges that are in the forefront of Utility and community needs.

This chapter emphasizes the specific Strategies, elaborating on how we are currently implementing them, or how we intend to implement them within the six-year context of this Plan. Many of the Plan’s associated financial and capital components have a 20-year perspective.

The Goals are:

- 1 - Water Quality** - Clean Water Act and Safe Drinking Water Act standards for nitrogen, fecal coliform and other constituents of concern in groundwater and surface water are met.
- 2 - Public Health** - No one is exposed to sewer overflows and excessive odors.
- 3 - Water Use** - Potable water use and greywater flows into the sewer collection system are minimized.
- 4 - Energy** - The Utility is more energy efficient and uses cleaner energy sources.
- 5 - Rates and Fees** - Utility rates and fees are equitable and affordable, minimizing rate increases while maintaining consistent levels of service.
- 6 - Integrated Water Resources** - Water resource utilities are planning together for long-term environmental, economic and social changes.
- 7 - Information** - Customers and community are informed about and involved in wastewater management activities.

At the end of the chapter, Table 9.2 summarizes the 33 Strategies of this Plan. For each strategy, the table indicates relative priority and whether or not we are currently implementing it.

Goals and Objectives are summarized in Table 9.1, showing how they respond to the Challenges described in Chapter 8, and to the Comprehensive Plan vision summarized in its draft Goal GU2:

Reliable [utility] service is provided at the lowest reasonable cost, consistent with the City’s aims of environmental stewardship, social equity, economic development and the protection of public health.

At the end of the chapter, Table 9.2 summarizes the 33 Strategies of this Plan. For each strategy, the table indicates relative priority and whether or not we are currently implementing it.

Table 9.1

Relationships between the Comprehensive Plan and Wastewater Plan

Wastewater Challenge	Comprehensive Plan Mandate	Wastewater Goal	Wastewater Objective
1. Existing infrastructure	Public health Environmental stewardship	1. Water quality 2. Public health	1A–Eliminate illicit discharges 1B–Manage OSS 2A–Reduce overflows 2B–Reduce odors 2C–Manage assets
2. Onsite sewage systems	Public health Environment stewardship	1. Water quality	1B–Manage OSS 1C–Encourage OSS Conversions
3. Extending sewers to new development	Economic development	5. Water quality	1D–Facilitate orderly expansion of sewers
4. Sea level rise	Economic development	6. Integrated water resources	6A–Integrate water resource activities
5. Use of drinking water resources	Environmental stewardship	3. Water use	3A–Reduce water use
6. Use of energy resources	Environmental stewardship	4. Energy	4A–Reduce energy use 4B- Replace generators
7. Overlapping agency responsibilities	Environmental stewardship	2. Public health 6. Integrated water resources	2A–Reduce overflows 6A–Integrate water resource activities
8. Equitable and predictable rates and fees	Social equity Economic development	1. Water quality 3. Water use 5. Rates and fees	1A–Manage OSS 3A–Reduce water use 5A–Coordinate management of water resource utilities 5B- Manage rates and fees
9. Public education and involvement	Social equity	7. Information	7A–Provide adequate staff and resources

9.1 Water Quality

Goal: Clean Water Act and Safe Drinking Water Act standards for nitrogen, fecal coliform and other constituents of concern in groundwater and surface water are met.

Protecting and improving local waters is a core responsibility of the Wastewater Utility. This responsibility necessitates the management of existing as well as future sewer systems. Problematic discharges of wastewater-related contaminants often occur over many years. These include discharges from illicit connections and onsite sewage systems (OSS). Meanwhile, future sewer extensions need to accommodate both new development and OSS conversions. The following objectives and strategies are aimed at reducing wastewater-related contaminants in receiving waters while encouraging urban development and re-development.

1A. Objective - Identify and eliminate at least two illicit discharges of wastewater into stormwater conveyance pipes and receiving waters each year.

1A1. Strategy - In partnership with the City's Storm and Surface Water Utility, detect and eliminate illicit discharges using water quality testing, GIS analysis, remote video inspection and funding assistance.

Nutrient and bacteria loading from cross connections of sewer pipes with stormwater pipes is a point source that can be identified and eliminated. The associated reductions in wastewater-related contaminants can be measured in terms of the volume of wastewater removed from Budd Inlet and its tributaries. For example, based on industry research, residences generate approximately 21 pounds of wastewater-related nitrogen per year.

In this strategy we will use water quality sampling of stormwater outfalls in concert with GIS land use and infrastructure analysis to efficiently and thoroughly locate cross connections between sewer and stormwater pipes. Further field investigations that incorporate dye testing, smoke testing, and televising of pipe systems will identify specific problems. Work to improve utility mapping is ongoing. Operations and Maintenance staff provide key services in accomplishing this work.

The City's Wastewater and Storm & Surface Water Utilities have been coordinating this work since 2011, in order to meet requirements established by their respective NPDES permits.

1B. Objective - Manage existing and potential new OSS so there is no net annual increase in the total number of OSS in Olympia's sewer service area.

1B1. Strategy - Refine regulations regarding new OSS and repairs of existing OSS in order to accommodate the limited use of new OSS systems in appropriate circumstances.

Under the 2007 Wastewater Management Plan, the City established restrictive regulations on where a new OSS could be permitted and where limited repairs to an existing OSS would be allowed. Based on recent OSS and water quality information, staff recommends revising these regulations to allow for new OSS if some specific conditions are met.

Proposed permitting criteria would consider (1) the extent of current OSS use in the vicinity of the proposed new OSS; (2) the degree to which the existing right-of-way between proposed new OSS and existing public sewer is developed; (3) whether or not the proposed OSS is to be located

in an infill lot; and (4) the surface and ground water risk of existing OSS in the vicinity of the proposed OSS as evaluated by Thurston County Environmental Health Department (See Section 4.2).

These revised OSS regulations will be developed within 18 months of Plan adoption and potentially adopted as revisions to the Olympia Municipal Code.

1C. Objective - Encourage OSS conversions through the Septic to Sewer Program.

The Olympia City Council approved revisions to the municipal code establishing the Septic to Sewer program, effective August 17, 2009. This voluntary program provides technical assistance and financial incentives for residential connection of onsite systems to sanitary sewer as well as cost recovery mechanisms for the City.

Under the program, the City waives the sewer general facility charge (GFC) if a resident using OSS makes a connection to the sewer system within two years of being notified of the sewer's availability.

The Utility has funding available to construct a limited number of neighborhood sewer extension projects. Property owners who choose to connect under the Septic to Sewer Program are required to reimburse the City some portion of the cost of constructing the sewer infrastructure. In selected neighborhoods, the City provides (1) a fixed construction cost to help property owners prepare financing; (2) a payment plan (\$200 per month) for properties that connect to the sewers; and (3) Utility subsidy for half of the construction costs over \$20,000.

Neighborhood sewer extension projects are selected based on established criteria and City Council approval.

1C1. Strategy - Provide Utility funding for sewer extensions associated with individual OSS conversions.

This proposed strategy will facilitate minor sewer service extensions into areas where OSS are prevalent. Costs for extending sewer to individual parcels converting to public sewer can be high. Under this strategy, the Utility will provide limited funding to help cover the cost of the minor sewer extensions. This strategy and its implementation criteria will be developed over the next 18 months with implementation by the end of 2014.

1C2. Strategy - Allow payment of wastewater connection fees for OSS conversions over longer periods of time.

Wastewater general facility charges (GFCs) and LOTT's capacity development charges (CDC) are one-time permitting fees charged new construction at the time of connection to the public system. The financial burden of these fees for residences converting from OSS to public sewer can be substantial (\$7,900 in 2013). With this strategy we will evaluate options for collecting GFC and potentially CDCs over a long period (e.g. 15 years). The GFC option would be implemented in the Olympia Municipal Code.

1C3. Strategy - Provide technical assistance and public education for individual and neighborhood OSS conversions to municipal sewer.

Converting OSS to municipal sewer is technically and financially challenging. The Utility has been providing one-on-one consultations with individual property owners and distributing information on OSS conversion through various media since 2008.

1D. Objective - Facilitate the orderly expansion of the public sewer system.

1D1. Strategy - Evaluate the use of alternative sewer technologies for appropriate sewer extensions.

Under most circumstances, a traditional gravity sewer collection system with a lift station and force main if topography warrants it, will continue to be the required method of sewer collection in areas to be developed, regardless of the source of funding or type of development.

However, we acknowledge that alternatives, such as pressurized grinder pump systems, are viable and appropriate for certain limited locations with unique constraints. There is, for example, an existing policy (see Appendix O) allowing for grinder pump systems in limited areas.

With this strategy, we will refine criteria for allowing grinder pump systems and potentially other technologies as they become technically available and suitable for use in Olympia. This strategy will be implemented through the municipal code estimated to occur two to four years after adopting this Plan.

1D2. Strategy - Allow the limited use of STEP systems for OSS conversions and infill development in neighborhoods currently served by STEP systems.

This strategy continues existing policies that prohibit the use of STEP systems for new subdivision and commercial development, while accepting that STEP may be the appropriate technology for OSS conversion and infill lot development within areas that are currently served by STEPS. Current restrictions on STEP systems will be evaluated. Potential criteria for allowing STEPS include only allowing them in small areas where the only possible access to public sewer within 1,000 feet is via an existing STEP main, documentation that the existing STEP main has adequate capacity, and ensuring that odor control needs are addressed.

Under State regulations, existing and potential future STEPs are the operational responsibility of the Wastewater Utility rather than the property owner. Implementation of this strategy must therefore continue to be highly restrictive of STEP use.

1D3. Strategy - Implement a green infrastructure project evaluation process for wastewater capital projects.

Tools are available to identify project-specific sustainability issues/challenges/opportunities (e.g. ISI's Envision program); encourage collaboration among staff across disciplines, Lines of Business and Departments; and help to refine and define elements.

This Strategy will ensure that the scope of projects identified in the Wastewater Utility's Capital Facilities Plan is sustainably defined on a consistent basis. The intent is to implement this process on several projects within two years of adoption of this plan, with full implementation within six years.

9.2 Public Health

Goal: No one is exposed to sewer overflows or excessive odors.

Managing the public health risks of sewage is a long-standing responsibility of the Wastewater Utility. Often sewer overflows and odors affect both public health and environmental quality.

2A. Objective - Reduce the number of sewer pipe blockages and the volume of sewer overflows annually.

2A1. Strategy - Continue to improve City preventive maintenance activities such as pipe cleaning, root control and minor repairs.

Regular and focused maintenance helps prevent sewer overflows by ensuring adequate capacity in the pipe system. Related work is a key responsibility of the Utility.

Increasing use of condition rating and asset management techniques will support refinements to this strategy over the next four years. Efforts to increase the capacity of asset management to help manage wastewater systems will be pursued.

In recent years, our in-house maintenance ability has increased to meet current needs. Wastewater operations and engineering staff discuss preventive maintenance issues bi-weekly. We document needs and track them until the issue is resolved. We implement emerging technologies as appropriate.

As the infrastructure system grows, so will the need to adequately support operations and maintenance work.

2A2. Strategy - Continue to provide adequate resources for improved mapping and documentation of the wastewater pipe system.

Efforts to improve our knowledge of the wastewater systems need to be maintained in the long-term. Efficiencies and effectiveness increase as our understanding of the complex pipe and pump systems improve. Additional resources may be needed in the long term to maintain this work effort.

2A3. Strategy - Implement education and enforcement efforts to reduce preventable blockages due to fats, oils and grease (FOG) build-up, with assistance from LOTT.

This strategy emphasizes the need for enhanced coordination between City wastewater and LOTT staff regarding the enforcement of pre-treatment regulations (OMC 13.20) and educational efforts associated with FOG. Both educational and regulatory measures will be refined and implemented by both entities within the next two years. Additional resources may be needed to accomplish this strategy.

2A4. Strategy - Reduce infiltration and inflow of groundwater and stormwater in prioritized areas so that pipe capacities are not exceeded.

Wastewater pipe capacities in Olympia are generally adequate regardless of infiltration and inflow. While infiltration and inflow (I&I) do not currently generate sewer overflows in the wastewater collection system, they do have an impact on the capacity of LOTT's wastewater

treatment facilities. Therefore, we will continue ongoing efforts to manage and reduce these unnecessary flows to avoid future capacity problems. For example, needed repairs to leaking pipes and manhole structures also reduce groundwater inflows.

Long-term refinements to I&I management will be developed as needed, in partnership with LOTT. Tools for reducing I&I include targeted construction projects and the separation of stormwater and wastewater flows from buildings. The 20-year capital facilities plan includes several projects that will reduce I&I.

2A5. Strategy - Separate combined wastewater/stormwater pipes in conjunction with stormwater and road improvements or residential repairs, when economically feasible.

Older areas of the City, especially downtown, combine storm and waste water flows in one pipe system that flows to the Budd Inlet treatment facility. Potential separation projects are identified and evaluated during redevelopment and street retrofit projects. In general, separation projects are pursued based on ease of implementation and costs. Several modest separation projects have been completed in recent years. While separation is not a Utility priority, coordination with LOTT's long-term capacity planning may result in future capital projects that have mutual benefits.

The City will continue to work with LOTT to identify important project and associated funding options.

2A6. Strategy - During sewer spills and other emergencies, take advantage of available regional resources through the LOTT Mutual Aid Agreement.

Access to readily available resources is important during emergencies. The existing LOTT agreement can be implemented as needed. Agreements and relationships will be updated and maintained.

2A7. Strategy - Coordinate public education activities with the City's Waste ReSources Utility to reduce use of under-sink garbage disposal units.

The Waste ReSources and Wastewater utilities share an interest in reducing the volume of compostable solid wastes that are introduced into the wastewater collection system through kitchen garbage disposal units. Compostable solid wastes can negatively impact the ability of STEP systems to function properly, and use of these disposal units may introduce solids and liquids that trigger pretreatment regulations covered under Olympia Municipal Code Chapter 13.20. Pretreatment regulations are jointly managed by the City and LOTT.

2A8. Strategy - Improve operations and maintenance capacity by continuing to incorporate new field technologies and providing adequate staff resources.

Technologies to increase the effectiveness of field operations and maintenance continue to emerge. An important recent example includes the use of trenchless pipe lining technology to substantially reduce the costs of pipe retrofits and the use of oxygen generation to manage hydrogen sulfide odors. As these technologies emerge, the Utility will help foster their development and use.

2B. Objective - Reduce odors from public sewer systems to acceptable levels.

2B1. Strategy - Resolve odor issues in a timely manner.

Staff respond to odor complaints, quantify the extent of the problem, and implement projects to retrofit pipe and pump systems with odor control technology through the capital facility planning process. Often, these mitigation efforts are iterative, culminating in an acceptable level of odor control. Odor management can be a critical neighborhood concern.

2C. Objective - Use computer-based asset management systems in order to achieve low infrastructure life-cycle costs at a consistent level of service.**2C1. Strategy - Continue pipeline condition rating using the Pipeline Assessment Certification Program (PACP), which tracks the physical integrity of the wastewater pipe system. In the longer term, evaluate staffing and equipment options for inspecting privately-owned sewer laterals.**

After eight years of implementation, the first comprehensive round of prioritized system inspections will be completed in early 2014. In future years, condition rating will continue for pipes according to their current condition and criticality, supporting the identification of pipes needing repairs or replacement. In doing so, the rating system will help determine financial and resource needs for the Utility.

Additional work is needed to evaluate the private pipe systems connecting residences to the public pipes in the streets. Staff will evaluate options for expanding the asset management program to incorporate other needs.

2C2. Strategy - Inspect manholes consistent with the Manhole Assessment Certification Program (MACP) for condition rating.

With the first round of prioritized PACP inspections soon to be completed, we will plan for wastewater manhole inspections using the MACP standards. In general, the wastewater system incorporates a manhole, or ground-level access structure, into every 300-400 feet of pipe. These structures are six to 20 feet deep with multiple pipes entering and exiting. Deterioration of these structures results in leaks, both out of and into, the wastewater system. Modest repairs can often appreciably extend the life of manholes. Resources needed to complete this work will be evaluated.

2C3. Strategy - Based on pipe and manhole condition rating outcomes, complete priority repairs and replacements of pipes and structures.

System repairs are currently incorporated into operation and maintenance work plans as well as capital facility projects. At this time, available resources are adequate. However, project needs will evolve over time. Refer to Chapter 10 for additional information regarding capital facility project planning.

2C4. Strategy - Inspect and condition rate lift stations and commercial STEP systems on a regular basis.

Lift stations and force mains present a high level of risk and vulnerability. Malfunctions in complex pumped systems can result in appreciable sewer overflows. Emergency responses can be extensive and may last more than a few hours. We emphasize the need to proactively track

the life cycle of these systems and complete needed retrofits prior to system failures. We have made substantial progress in updating lift stations and force main in the past six years. Refer to Chapter 10 for additional information.

9.3 Water Use

Goal: Potable water use and greywater flows into the sewer collection system are minimized.

In terms of long-range capital facilities planning, reducing unnecessary wastewater flows is financially advantageous to the Wastewater Utility, the Drinking Water Utility, the LOTT Clean Water Alliance and ratepayers.

3A. Objective - In concert with the Drinking Water Utility, reduce non-irrigation residential water use.

3A1. Strategy - Implement a volume-based residential rate structure for the Wastewater Utility.

Basing residential wastewater rates on the volume of drinking water consumed should result in improved water use efficiencies for both the Wastewater and Drinking Water utilities. Rates for commercial wastewater customers are already flow-based.

Additionally, this strategy addresses potential financial inequity issues associated with the current flat monthly rate for residential wastewater. As Utility revenues will need to be maintained through the rate re-structuring, rates for some customers will inevitably increase. A financial analysis has been completed as part of this Plan and we will initiate an effort to implement a volume-based rate structure in 2014. Also see Strategy 5B1.

3A2. Strategy - Coordinate public education activities with the Drinking Utility.

The Drinking Water Utility supports extensive public education efforts focused on water conservation and reuse. Beginning in 2014, we will better coordinate public messages regarding the linkage between water conservation and wastewater generation.

3A3. Strategy - Allow and promote greywater subsurface irrigation alternatives in concert with Thurston County.

Consistent with building codes and public health expectations, we will advocate for the voluntary use of greywater systems. The Thurston County Health Department is the local regulatory authority for establishing greywater standards. We will address this strategy sometime during the six-year planning period, anticipating initial action by Thurston County.

9.4 Energy

Goal: The Utility is more energy efficient, and uses cleaner energy sources.

City-wide policies mandate measures to reduce energy consumption.

4A. Objective - Reduce the Wastewater Utility's energy use by 5% within six years of adopting this Plan.

4A1. Strategy - Complete an energy audit for all lift stations.

Lift stations are the primary consumers of electrical energy in the wastewater system. With guidance from available industry and/or Washington state energy self-assessment programs, we will evaluate wastewater system energy use. Other potential efficiencies (e.g., vehicles, buildings) are currently addressed by City-wide policies and practices.

4A2. Strategy - Increase frequency of sewer force main cleaning.

This strategy employs the use of modern “pigging” technology for thoroughly cleaning the interior of high priority pipes. Use of the technology reduces friction and increases pipe flow capacity, reducing pump run hours and energy use. Maintenance staff will implement this strategy beginning with a demonstration project planned for the year 2016.

4A3. Strategy - Minimize the number and energy use of new lift stations as part of wastewater basin planning.

This strategy involves a more detailed look at “basin build-out” in areas within the Sewer Service Area for which sewer infrastructure is not currently available. While this and earlier plans have generated needed information regarding planned sewer extension projects in the various watersheds, more detailed efforts to define potential efficiencies are needed. The work will be completed within the six-year planning period.

4B. Objective - Reduce diesel emergency generator emissions by replacing the two oldest generators in the system within six years of adopting this Plan.**4B1. Strategy - Pursue federal and State grant programs to assist in financing clean diesel fuel retrofits for generators.**

The intent of this strategy is to replace older diesel generators with new ones that not only are more fuel efficient, but produce significantly less air pollution.

9.5 Utility Rates and Fees

Goal: Utility rates and fees are equitable and affordable, minimizing rate increases while maintaining consistent levels of service.

A utility can best provide consistent levels of service by managing revenue and expenditures to minimize changes in rates and fees in the short term, and predict them accurately in the long term. While this goal and the following objectives and strategies work towards achieving this balance, other strategies particularly under Water Quality and Water Use Goals, will significantly impact how the Wastewater Utility determines and collects rates and fees.

5A. Objective - Coordinate the financial management of the three water-based utilities so that utility rate increases are distributed over time.**5A1. Strategy - Conduct regular financial studies, coordinated with other water resource utilities and potentially including LOTT.**

We evaluate rates and other financial needs during the annual rate analysis and in updating the Wastewater Management Plan. These evaluations consider management needs, levels of service, and growth assumptions. Balancing rate increases among the utilities is an ongoing emphasis.

5B. Objective - Manage utility rates and connection fees consistent with the City's guiding principle of growth paying for growth.

5B1. Strategy - Update utility rates and general facility charges (GFCs) to reflect costs of providing needed services, while looking for opportunities to improve the equitable distribution of charges.

The financial evaluation associated with this Plan evaluates the potential for basing residential wastewater monthly rates on drinking water consumption. Instead of the current flat rate for all residential wastewater customers, rates would be partially based on wastewater generation as measured by drinking water consumption (See Strategy 3A1).

Similar work in 2011 responded to community interest in acknowledging the limited generation of wastewater by small accessory dwelling units. Connection fees for the units were reduced. Strategy 1B4 of this Plan will allow the payment of GFCs for OSS conversions to be spread over time. Similar efforts will continue with this Strategy as part of a regular review of rates and fees.

9.6 Integrated Water Resources

Goal: Water resource utilities are planning together for long-term environmental, economic and social changes.

Water resource needs and issues are increasingly managed collaboratively among various City entities. A proactive management approach will not only minimize the adverse impacts of changes over time, but guide us toward achieving our community's sustainability goals.

6A. Objective - Integrate Water Resource activities that share common goals, resources and/or assets.

6A1. Strategy - Enhance watershed-based planning with input from Storm & Surface Water, Drinking Water, and Wastewater staff.

This strategy emphasizes the intent to identify and act upon goals common to all three water resource utilities. Commonalities between work groups are increasingly apparent. For example, the Wastewater and Storm & Surface Water programs share an interest in water quality improvement. Similarly, the Wastewater and Drinking Water programs share common interests in water conservation and reuse.

6A2. Strategy - Plan for the anticipated impacts of sea level rise.

With this strategy we will build upon ongoing work by the City Storm & Surface Water Utility and LOTT, by incorporating sea rise into wastewater infrastructure planning for the downtown area and other parts of the sewer service area adjacent to Budd Inlet and Deschutes River.

We will also quantify the threats of sea rise to the wastewater collection system through vulnerability assessments (e.g., EPA's CREAT software) and site specific investigations. A clearer understand of long-range infrastructure needs may result in specific capital projects.

9.7 Information

Goal: Customers and the community are informed about and involved in wastewater management activities.

Instant availability of information in society today has changed customer expectations.

7A. Objective - Provide adequate staff and resources to keep customers and the community informed and involved.

7A1. Strategy - Maintain technical staff capacity for one to one discussion and problem-solving with wastewater customers; wastewater planning and troubleshooting; and design review.

Wastewater technical and regulatory issues are complex. Maintaining our capacity to be helpful and responsive is a key service to the community. Resolving various concerns from the development community and both commercial and residential customers requires detailed knowledge about the wastewater infrastructure.

Decisions about gravity sewer and STEP system availability and potential extensions, onsite sewage system permitting, and problem troubleshooting are financially important to those effected by wastewater policies. Code enforcement, environmental monitoring and public education on specific issues are also important. Communicating this information often requires detailed and site specific interactions with customers.

7A2. Strategy - Update and expand the Utility's website and other media to disseminate information consistent with the objectives of this Plan.

With the exponential increase in use of electronic media, customer and community expectations are high concerning access to digital information associated with the Utility.

Other efforts will include increasing the amount and type of information available through the City's website, and actively approaching the utility's customer base to determine their concerns.

7A3. Strategy - Coordinate customer and community education efforts with the other water resource utilities and LOTT.

Currently, there are a variety of methods through which the four water resource utilities and LOTT provide information and educate their customers. Under this strategy we will look at what these other utilities are doing to approach their customers, aside from information available on their respective websites, and identify partnership opportunities that promote a deeper understanding of the relationship between water resources and our local communities.

9.8 Summary Table of Strategies

Table 9.2 summarizes the 35 Strategies, showing for each one its relative priority, whether or not we are currently implementing the Strategy, if not when it is going to be implemented, whether the Strategy has an existing program associated with it, and whether capital project(s) are associated with it.

Table 9.2
Status of Strategies

No.	Strategy	Relative Priority	Existing or New Program	When ¹	Capital Project
Water Quality					
1A1	Illicit discharge reduction	High	Existing	Ongoing	Maybe
1B1	Modify OSS regulations	High	Both	Ongoing	No
1C1	Fund limited sewer extensions	Moderate	New	2014/15	Yes
1C2	Connection fee payment plan	Moderate	New	2014	No
1C3	OSS technical assistance	High	Existing	Ongoing	No
1D1	Support alternative technologies	High	New	2014	No
1D2	Modify STEP regulations	High	New	2014	No
1D3	Project evaluation process	Medium	New	2014-19	No
Public Health					
2A1	Preventive pipe maintenance	Medium	Existing	Ongoing	Yes
2A2	Mapping and documentation	Medium	Existing	Ongoing	No
2A3	FOG management	Medium	Both	2015	No
2A4	I&I reduction	Low	Both	2017	Yes
2A5	Combined sewer separation	Low	Existing	2020	Yes
2A6	LOTT mutual aid agreement	Low	Existing	Ongoing	No
2A7	Reduce solid wastes into sewer	Low	New	2015	No
2A8	New field technologies	Medium	Existing	Ongoing	No
2B1	Odor control	Medium	Both	Ongoing	Maybe
2C1	Pipe condition rating	High	Existing	Ongoing	No
2C2	Manhole condition rating	Medium	New	2016	No
2C3	Priority repairs	High	Existing	Ongoing	Yes
2C4	Lift station improvements	High	Existing	Ongoing	Yes

Table 9.2, continued
Status of Strategies

Water Use					
3A1	Volume-based rates	High	New	2014	No
3A2	Education with Drinking Water Utility	Medium	New	2014	No
3A3	Greywater irrigation	Low	New	2016	No
Energy					
4A1	Energy self-assessment	Medium	New	2015	Maybe
4A2	Cleaning force mains	Low	New	2016	No
4A3	Minimize new lift stations	Medium	Existing	2017	Maybe
4B1	Replace older diesel generators	Medium	New	2017	Yes
Rates and Fees					
5A1	Regular rate studies	High	Existing	2014	No
5B1	Equitable rates	High	New	2014	No
Integrated Water Resources					
6A1	Watershed-based planning	Medium	New	2013	No
6A2	Sea level rise	Medium	Existing	Ongoing	Maybe
Information					
7A1	Maintain technical staff	High	Existing	Ongoing	No
7A2	Update & expand website	Medium	Existing	Ongoing	No
7A3	Partnerships with other utilities	Medium	New	2014	No



Capital Facilities Plan

Chapter 10

Both operations and maintenance and capital facility planning are fundamental to the infrastructure-dependent Wastewater Utility. The lift stations, pipes, manholes and STEP systems that make up the wastewater infrastructure vary in age, materials and structural integrity. At some point in its life, infrastructure is best replaced or upgraded through the capital facilities planning process.

Ongoing work to systematically televise and evaluate the condition of the individual pipes helps prioritize repair and replacement needs. As needed, pipes can be repaired or replaced by City crews, or for more involved work, by contractors. Contractor work is typically funded through the City's Capital Facilities Plan (CFP). Pipe capacity upgrades, lift stations rehabilitations, and conversion of onsite sewage systems to public sewer are also included in the CFP. These work efforts will continue in the years to come.

The projects contained in the CFP are funded annually through Wastewater Utility rates and General Facilities Charges (GFCs). We pursue bonds and Washington State-managed low interest loan and grant programs when needed and available. Chapter 11 details a financial strategy involving a combination of cash and debt financing of capital projects.

This chapter discusses programs and systems that characterize the condition of existing infrastructure, identify infrastructure deficiencies and prioritize capital projects for both a six and a 20-year planning horizon. The prioritized projects for both six and 20 years are summarized at the end of this chapter in the basic format of the CFP.

10.1 Physical Condition of the Gravity Sewer Collection System

Assessing the condition of existing infrastructure is a necessary component of effective asset management and capital planning. The vast majority of the wastewater collection system consists of gravity sewer mains and manholes. Sewer mains are televised using remote tractor-mounted cameras that travel through pipes and send video images to above-ground personnel. The videotapes are stored and evaluated at a later date.

The condition of gravity sewer pipes is assessed using the Pipeline Assessment and Certification Program (PACP) developed by the National Association of Sewer Service Companies (NASSCO) and accepted as an industry standard. We store and manage sewer pipeline videotapes and descriptive data using Granite XP software.

The condition of gravity sewer pipes is assessed on an ongoing basis, using the following criteria:

- Pipeline integrity (physical structure, slope and alignment).
- Inflow and infiltration (inflow of stormwater from catch basins and roof drains, and infiltration of groundwater through pipe and manhole leaks).
- Operating efficiency (extent to which the system operates as designed with minimal input of energy or operation and maintenance).
- Potential for illicit cross connections (discharges to stormwater pipes and surface waters)
- Risk and vulnerability (effect of potential failure on public or environmental health).

We began our ongoing condition assessment work in July 2005. In 2006, we estimated it would take six years to complete an initial detailed assessment of the 185 miles of gravity collection pipes. As of June 2013, we completed video inspections of approximately 92% of the gravity collection system, including all of the highest risk and most time consuming pipes.

In partnership with LOTT, computerized flow monitors are installed in key pipes in order to track flows over time. The data provides information on wastewater flows as well as inflow and infiltration and operating efficiency. Lift stations are monitored continuously through the Utility's supervisory control and data acquisition (SCADA) system.

The general characteristics of the wastewater pipes are summarized as follows.

Pipeline Integrity

Due to the full implementation of PACP-based video pipe inspections in the last 6 years, the structural integrity of our sewer pipe network is now well-understood. Approximately 30 percent of the sewer gravity pipes were installed prior to 1960 and are near or past their 50-year design life. The likelihood of leaks due to settlement, deterioration, sediment accumulation and root intrusion may increase exponentially in these pipes. Another 20 percent of the pipe system was installed between 1960 and 1975.

Because concrete and asbestos cement pipes were still widely used during this period, the pipes are susceptible to corrosion and deterioration from hydrogen sulfide gas, such as that produced by STEP systems. Several acute corrosion problems related to STEP systems were discovered in early 2006 and addressed with manhole and concrete pipe liner projects. Several additional projects to address corrosion are needed and are included in this Plan.

Televising and condition rating of all sewer pipes should be complete in mid-2014. Our work to date indicates the following:

- 77% of the pipes are in good condition
- 9% are in fair condition
- 6% are in poor condition
- 8% remain to be inspected. Many of these pipes are relatively new and are assumed to be in good condition.

These data suggest that the gravity sewer system is in manageably good condition. Repairs can be completed proactively in order to avoid costly and/or extensive emergency repairs. Often times, repairs are needed to only a small section of the pipe. Repairs to problematic pipes are completed by in-house or contractor crews. With planning, cost-effective trenchless repair technology is the preferred choice for repairs. With this technology, an epoxy impregnated sock is pulled through the faulty pipe, expanded to meet the sides of the pipe and cured in-place. The pipe is repaired at a fraction of the cost of pipe excavation and subsequent street reconstruction.

The pipe televising and condition rating program indicates that needed pipe replacements and repairs can be addressed proactively and at manageable costs.

Pipe inspections and condition rating are a key work element of the Utility. Operations and maintenance crews in concert with engineering staff provide dedicated resources for pipe cleaning and inspection.

Inflow and Infiltration

Inflow and infiltration (I&I) mainly occurs in combined storm/sanitary sewers in the downtown, South Capitol neighborhood and portions of northeast and west Olympia and in older faulty pipes. Inflow is precipitation that enters sewer pipe from catch basins within the roadway and roof downspouts. Infiltration results from groundwater entering sewer pipes through cracks, bad joints, or leaky manholes. These inputs of storm and groundwater can result in significant excess flows and surcharging of the pipes during the wet season. On rare occasions, surcharges during large storms can extend above the manhole rim with wastewater discharging to the street.

The Wastewater Utility reduced I&I in the 1990s through several extensive pipe replacement projects in West Olympia. The work was undertaken as part of an agreement with LOTT that addressed wet season flow reduction.

Currently, flow monitoring at most of our lift stations tracks seasonal variations in pipe flows. High wet weather flows are typically adequately-managed by the LOTT treatment facility. In the future, wet weather flows due to infiltration may decrease as pipes and manholes are rehabilitated through the condition rating program. Additionally, combined pipes responsible for inflow are separated as feasible and cost effective. Inflow and infiltration are adequately managed by the Wastewater Utility.

Operating Efficiency

Older areas of the City with smaller diameter pipe, separated joints and other challenges can require more frequent maintenance, particularly pipe cleaning and root control. These areas are identified through periodic review of the work order system and the scheduled maintenance program. In recent years, high frequency maintenance has consumed approximately 5% of operation and maintenance resources on an annual basis.

On a case-by-case basis, the cost of increased maintenance needs is compared to reconstruction. For example, one well-known high maintenance area—the South Capitol neighborhood—is being adequately served by careful flow evaluation, extra maintenance, and isolated, small-scale rehabilitation projects. This highly managed approach to capacity limitations is cost effective, given the high costs of extensive reconstruction. Other localized areas of high maintenance in

Olympia are best served, however, by reconstruction. Depending upon the scale of the work effort, construction projects are completed in-house or by contractors through capital facilities funding. With the exception of lift station upgrades, current capital facilities planning does not include projects targeting operating inefficiencies.

Grease accumulation in sewer pipes, primarily from food service establishments, is also a maintenance problem. Unnecessary clogging of pipes reduces operating capacity and can result in sewer overflows. Proper restaurant procedures for managing fats, oils and grease (FOG) onsite can prevent this problem. LOTT and the City provide educational materials to restaurant owners and issue citations for grease containment violations. A more rigorous program to enforce grease abatement, including the enforcement of existing pretreatment regulations in OMC 13.20, is scheduled for implementation within the next several years.

Illicit Cross Connections

The Wastewater Utility partners with the City Storm and Surface Water Utility to actively inspect their pipe systems for unintentional cross-connections. Improperly constructed pipes and manholes can result in ongoing discharges of wastewater to the stormwater pipe systems. In recent years, our inspections have discovered one or two of these cross connections a year, especially in older areas of the City.

The respective wastewater and stormwater systems have been inspected for design features that are correlated with cross-connections such as pipes in close proximity to each other, unclear construction blueprints, and sewer pipes passing through stormwater pipes. Potential problem areas have been field investigated. Other areas that may be susceptible to an unintentional cross-connection during future construction have been flagged on utility maps. These work efforts and the coordination between Wastewater and Stormwater will continue.

Risk

Structural failures in wastewater pipes can result in sewer overflows impacting public and environmental health. Our evaluation of the sewer pipe network has focused on improving older pipes susceptible to problems. Additionally, ensuring the non-stop operation of lift stations is a program priority (see below).

Given the current knowledge of pipe and lift station condition, the risk of infrastructure failure is modest. High risk infrastructure is well-managed. Systems in close proximity to surface waters are prioritized. However, the extensive scale of the wastewater system suggests that failures will occur. Utility staff plans for emergency response to failures thereby minimizing impacts.

Summary of Sewer Pipe Condition

Overall, the Wastewater pipe network is well-understood and in manageable condition. Future work can focus on proactive maintenance and timely repairs. Results suggest the need for ongoing scheduled repairs, but not catastrophic failure or unanticipated expenditures. Operation and maintenance resources may need to be augmented as the City grows and the infrastructure continues to age.

10.2 Capacity Analysis of the Gravity Sewer Collection System

Capacity analysis is used to identify improvements needed in existing infrastructure to increase capacity for planned or proposed development(s), as well as to plan for extending sewer into unsewered areas. Capacity improvements in the gravity sewer system may be needed for several reasons:

- New development “upstream” may increase demand on existing “downstream” pipes and pumps.
- New development may require extending the system to additional areas.
- Pipes may have been under-designed or may receive excess flows due to stormwater inflow and groundwater infiltration.

In 2006, a computer model was used to estimate wastewater flows, based on the current and projected population, land use and water entering the system from inflow and infiltration (I&I). The model results were compared to the capacity of existing pipes and pump stations. The model identified areas of the system currently over capacity or projected to be over capacity within a 20-year time frame. The model inputs and outputs were re-evaluated in 2012. The model remains a valid tool for this planning effort.

Flow calculations and the associated computer simulations were calibrated based on actual data collected at the LOTT Budd Inlet Wastewater Treatment Plant and 23 flow monitoring locations spread throughout the LOTT service area. The sewer model was designed to simulate a 10-year peak hour storm event. See Appendix C-1 of the 2007 Wastewater Plan for a description of the model and methodology used.

While the computer model mainly focused on pipes larger than eight inches in diameter, it included many of the City’s eight-inch pipes located in key areas, or areas deemed critical by City staff. The model incorporated 20 lift stations, including two LOTT stations and 18 of the City’s stations.

For purposes of determining capacity limitations, three criteria were defined:

- Depth to flooding - the height from the maximum water surface elevation to the manhole cover.
- Pipe surcharge ratio - the ratio of the maximum modeled hydraulic grade to the pipe diameter (surcharge ratio of 1.0 indicates the pipe is completely full).
- Percent capacity - the projected flow through the pipe, divided by the full pipe flow capacity.

Capacity Limitations

The model helps us understand potential capacity limitations that might occur within the 20-year planning horizon. Population growth is anticipated to occur as projected in the 2007 Plan. Since growth and population projections in the years 2007-2012 did not meet previous expectations, the model results may be conservative and overestimate flows. The validity of the 2006 model is supported modest growth.

The model simulations identified several existing and future capacity limitations in the gravity collection system, as summarized below and shown on the maps in Figures 10.1 and 10.2. Some of these have already been addressed.

Figure 10.1
Modeled Capacity Limitations for 2007 - 2010

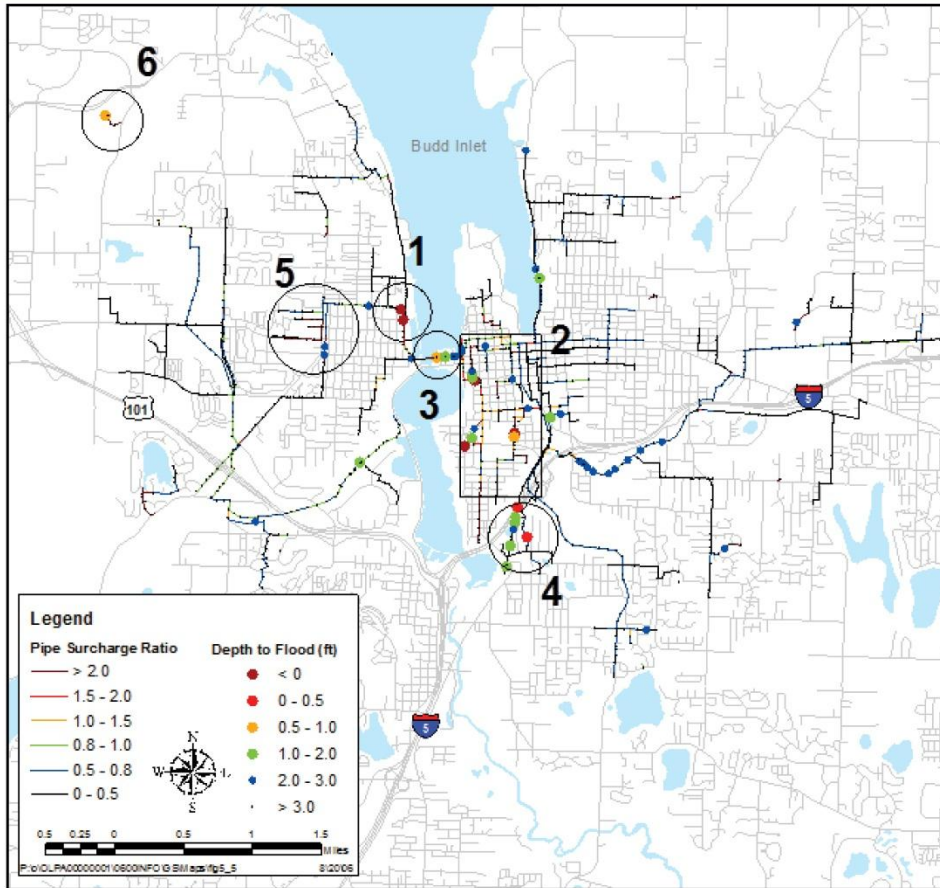
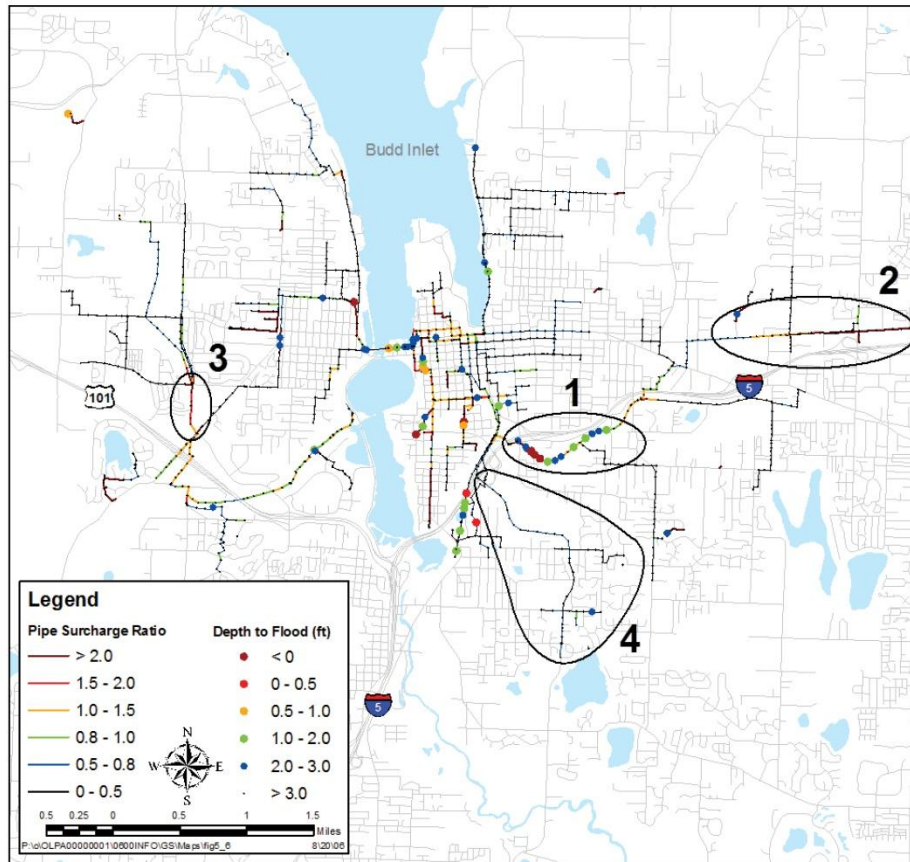

Figure 10.2

Projected Capacity Limitations for 2025



Existing capacity limitations were identified in six locations as shown in Figure 10.1. Model runs for the next several years showed no additional developing limitations. The six locations are described below:

1. West Bay Road near Harrison Avenue. Flow limitations were corrected as part of the 2007 Wastewater Plan implementation.
2. Downtown Olympia. The identified problem addresses modeling uncertainties in downtown Olympia. Flow in the complex downtown Olympia portion of the system is largely unknown. Much of this system is comprised of combined sewers, and many of these sewers have not been the subject of detailed flow monitoring studies. Because of the high amount of inflow associated with the combined system, coupled with the age of many downtown pipes, targeted flow monitoring began in August 2006. The recent monitoring did not identify flow capacity concerns, though some level of uncertainty remains. Sewer overflows in downtown have not been observed in recent years.
3. 4th Avenue. Capacity upgrades at the east side of the 4th Avenue Bridge have been completed as part of the 2007 Wastewater Plan implementation.

4. Capitol Blvd/Henderson Blvd/Railroad Interceptor. LOTT has completed needed improvements.
5. Division-Jackson Lift Station tributary area. Several projects increasing the capacity of the lift station pumps, as well as targeted pipe repairs, have significantly reduced the risk of surcharging.
6. Kaiser Road Lift Station Tributary Area. The sewer pipes upstream of many of the lift stations, including the LOTT Kaiser Road Lift Station, appear surcharged in the simulations. However, the lift stations intentionally use the capacity of upstream sewers to store flow during heavy storm events. These systems operated as designed and do not pose a risk of flooding.

Future capacity limitations for the year 2025 are shown in Figure 10.2. The four new capacity limitations are listed below:

1. LOTT Indian Creek Interceptor. During storm events, this large interceptor pipe is projected to surcharge heavily with several flooded manholes. This limitation is caused by a narrowing of the pipe from 30 to 24 inches in diameter
2. LOTT Martin Way Interceptor. During storm events, this interceptor was projected to surcharge near College Street and Lilly Road. LOTT has connected an overflow bypass pipe thereby reducing the risk of manhole flooding in this area.
3. LOTT Grass Lake Interceptor from Capital Mall Drive to Mottman Road. Under peak hourly storm conditions, this interceptor pipe will surcharge, creating a flow backup at the intersection of Capital Mall Drive and Cooper Point Road. However, because the depth of the interceptor at the confluence is approximately 13 feet, the two or three feet of projected surcharging are not expected to present a risk of manhole flooding.
4. Henderson Boulevard and Boulevard Road. The scenario for 2025 shown in Figure 10.2 assumes that all flows in the Southeast Watershed Basin (Figure 10.3) continue to be routed to the Budd Inlet Treatment Plant via sewers along Henderson Boulevard and Boulevard Road. If this remains true, both of these systems could experience storm-related surcharging in the future. However, the model indicated that the depth of surcharging in both Boulevard Road and Henderson Boulevard systems does not pose a major risk of manhole flooding.

Figure 10.3

Southeast Watershed Basin

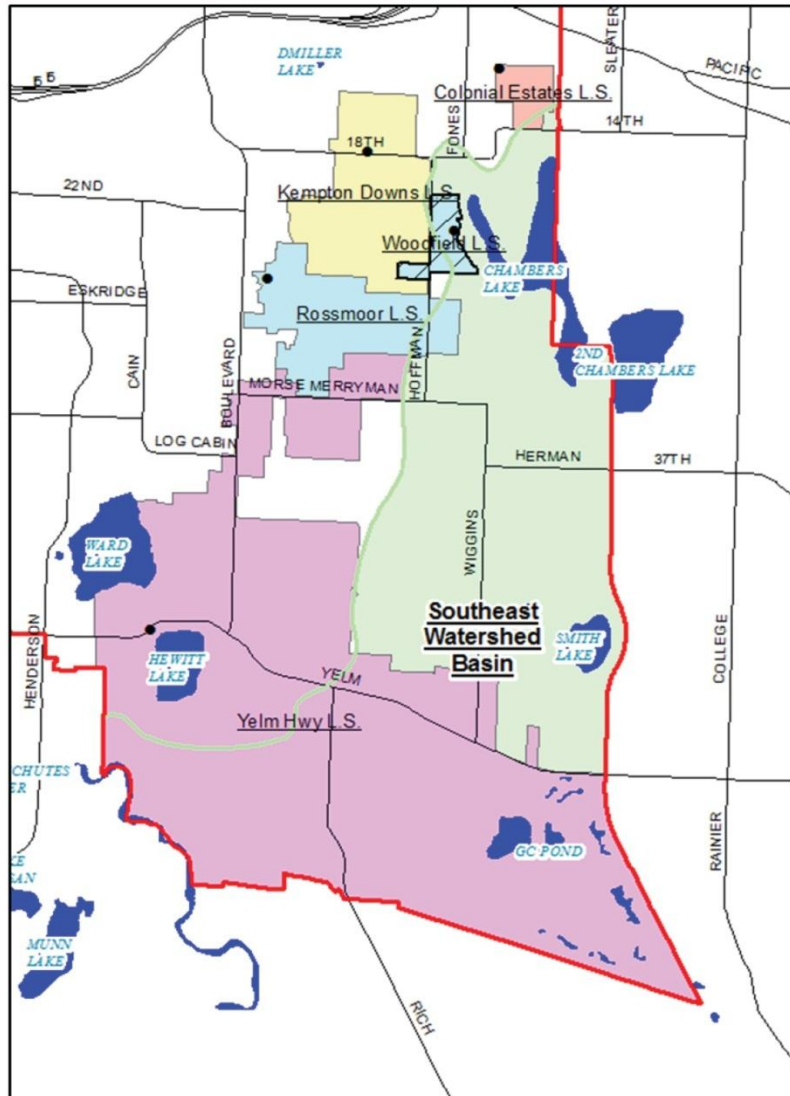

Annual Capacity Analysis

LOTT continues to analyze the capacity of the City's critical sewer mains using a modified version of the model developed in 2006, and provides annual capacity reports that focus on flows and loadings, I&I and flow monitoring, and capacity assessment. See Appendix N for the 2011 Inflow & Infiltration and Flow Monitoring Report. We review these reports on an annual basis with LOTT as part of shared long range planning efforts.

10.3 Condition Assessment of Lift Stations and Force Mains

The condition of our lift stations and force mains was assessed using the criteria described in Section 10.1 (Integrity, inflow and infiltration, operating efficiency, and risk/vulnerability).

In 2006, seven lift stations were identified as having major physical deficiencies: Black Lake, West Bay, Division & Jackson, Division & Farwell, Miller & Ann, Kempton Downs and Water Street. Projects addressing deficiencies at all seven of these lift stations have either been completed or are currently underway in 2013.

Table 3.2 in Chapter 3 shows the age, type, and upgrade/replacement project date (if applicable) of the 33 lift stations that the City owns and/or manages. A vulnerability assessment of lift stations older than 20 years was completed as part of this plan and is included in Appendix G. Typical problems include aging electrical, mechanical, and performance monitoring systems.

The results of the assessment indicate the need for continued upgrades to older lift stations. Priority lift stations include:

- Miller and Central
- Miller and Ann
- Water Street
- Old Port 2
- Roosevelt and Yew

Upgrades to the identified lift stations consistent with the schedule provided in Table 10.3 are expected to minimize risks for acute or chronic failure.

Of the 8.5 miles of force main pipe, 40 percent are constructed with older materials - concrete or asbestos cement (AC). The remaining 60 percent are constructed with more durable PVC pipe. All the remaining concrete and AC force mains are prioritized and planned for replacement. Untimely failure of these pipes is not anticipated. See Table 10.3.

10.4 Capacity Analysis of Lift Stations and Force Mains

Besides assessing the structural and mechanical integrity of the lift stations and force mains, the stations were evaluated for the adequacy of their capacity by comparing design capacity with measured capacity. The comparison confirmed that there are no current capacity deficiencies.

Future capacity limitations at the following lift stations are governed by growth/build out conditions:

- Cedrona
- Ken Lake
- Miller and Central
- Old Port 1
- Old Port 2
- Rossmoor

The land use build out projections and associated pump limitations assume that the City and UGA are allowed to continue to a maximum reasonable population density of eight residents per acre. Upgrades to these lift stations have been incorporated in long-term capital facility plans (Table 10.3).

10.5 Condition Assessment of the STEP Systems

All STEP systems in Olympia have been installed in the past 25 years and have a life expectancy of at least 40 years. A condition assessment, completed in 2006 and revisited in 2012, showed no structural or condition issues with the STEP pipelines. Since all pipes are made with PVC materials, future problems with pipeline integrity are unlikely. Infiltration is also unlikely, since STEP systems are tightly sealed and pressurized, and installed using new construction techniques.

STEP tanks, however, which are typically constructed of concrete, may over time develop structural issues related to corrosion. Hydrogen sulfide gas produced by STEP effluent is corrosive to concrete. While no active evaluation of the condition of existing tanks has been completed, there have been no documented structural failures of STEP tanks. Still, plans to replace a certain percentage of tanks have been built into this plan's 20-year planning horizon.

Similarly, effluent STEP pumps have been shown to last 20 or more years, with at most replacement of the "liquid end" (moving parts) part of the pump completed as part of regularly scheduled services. Due to the number of STEP systems installed in the last 20 years, though, it is anticipated that at some point in the 20-year planning horizon these pumps will need to be replaced at a high enough frequency that capital funding will be necessary. In general, STEP systems are currently performing adequately.

Commercial STEP systems requiring considerable City maintenance will continue to be a priority for conversion to gravity sewer service. Projects are prioritized are gravity sewer becomes available at the site. One commercial STEP conversion is anticipated by this Plan.

10.6 Major Sewer Extensions

Major extensions of sewer infrastructure will be needed to service outlying areas of Olympia and its UGA. These projects will be prompted by new development and are therefore anticipated to be completed with private funding. Potential projects include the South Bay Road and the 28th/Cooper Point extensions. These two projects as well as other necessary extensions may be included in future Capital Facility Plans and identified as privately-funded projects.

Several sewer extensions associated with transportation improvements are anticipated within the 20-year planning period of this Plan. One project, the Boulevard Road Roundabout at Morse Merryman, is projected to occur within the next six years. A sewer extension project to extend gravity sewer south on Boulevard Road from near Washington Middle School to the Log Cabin Road Roundabout will be completed as part of this transportation improvement project, and funded by utility funds. These projects are authorized and managed by the Utility through the capital facility program.

10.7 Summary

Based on the Condition and Capacity Assessments completed for the various types of wastewater infrastructure, needed projects are identified for funding in the next 20 years. The projects are summarized in Tables 10.1-4 below utilizing the funding categories currently used in the Capital Facility Plan (CFP).

The list of projects is tentative. It will be evaluated and refined during annual capital facility planning processes. However, it provides a projection of likely projects and their potential funding requirements. Many of the projects are proactive in nature.

Figure 10.4 shows the locations of all but the recurring projects. A discussion of funding of these projects, including whether a project is entirely or partially funded by rates and/or General Facility charges, is included in Chapter 11.

Additional minor projects (system upgrades associated with ongoing asphalt overlays, sewer system planning, and infrastructure planning) are included in the CFP as annual allocations as presented in Tables 10.5 and 10.6.

Table 10.1

Repair and Replacement Projects

No.	Project Name	Description	Cost (\$K)	Timing
1	Prioritized Repairs	Major repairs using trenchless technologies	\$265	Annual
2	Spot Repairs	Minor open-cut repair work	\$100	Annual
3	Manhole Repair and Replacement	Repairs of structural deficiencies and leaks	\$100	Every 3 years
4	Commercial STEP Conversions on Yelm Highway	Convert approximately 5 Commercial STEPs to gravity connections along Yelm Hwy	\$420	2016
5	Pipe Corrosion Abatement	Hydrogen sulfide reduction system in SE neighborhood	\$150	2014
6	Pipe Corrosion Abatement	Hydrogen sulfide reduction system in NE neighborhood	\$150	2016
7	STEP Pump Replacement	Replace 25% of STEP pumps	\$300	2025
8	STEP Tank Replacement	Replace 25% of residential STEP tanks	\$1,500	2030

Table 10.2

Lift Station Improvements

No.	Project Name	Description	Cost (\$K)	Timing
9	Black Lake LS Upgrade	Replace lift station	\$1,100	2014
10	Water Street Generator	Replace existing diesel generator	\$150	2015
11	28 th Ave. NW LS Property Purchase	Purchase property for future LS	\$100	2015
12	Miller and Central LS Upgrade	Replace existing wet well and pumps	\$750	2016
13	Miller and Ann Generator	Install diesel generator	\$60	2017
14	Water St Force Mains Upgrade	Replace 18 and 30-inch force mains	\$900	2018
15	Old Port 2 LS Upgrade	Increase capacity	\$600	2019
16	Roosevelt and Yew LS Upgrade	Increase capacity and potentially relocate	\$600	2021
17	Old Port 1 LS Upgrade	Increase capacity and potentially relocate	\$600	2022
18	Jasper LS Upgrade	Replace lift station	\$130	2023
19	AC Force Main Upgrades, Phase 1	Replace AC force mains at various locations	\$900	2024
20	Rossmoor LS Upgrade	Replace lift station	\$500	2025
21	East Bay Marina LS Upgrade	Replace lift station and force main	\$750	2027
22	AC Force Main Upgrades, Phase 2	Replace AC force mains at various locations	\$900	2029
23	Water St LS Replacement	Relocate and replace lift station	\$4,600	2032

Table 10.3

Sewer Extension Projects

No.	Project Name	Description	Cost (\$K)	Timing
24	Boulevard Sewer Extension at Morse Merryman Roundabout	Sewer main extension south to Log Cabin Roundabout	\$750	2017
25	Future Sewer Extension at a Roundabout To Be Determined	Sewer Main Extension at Future Roundabout	\$750	2023, 2029

Figure 10.4
Project Location Map

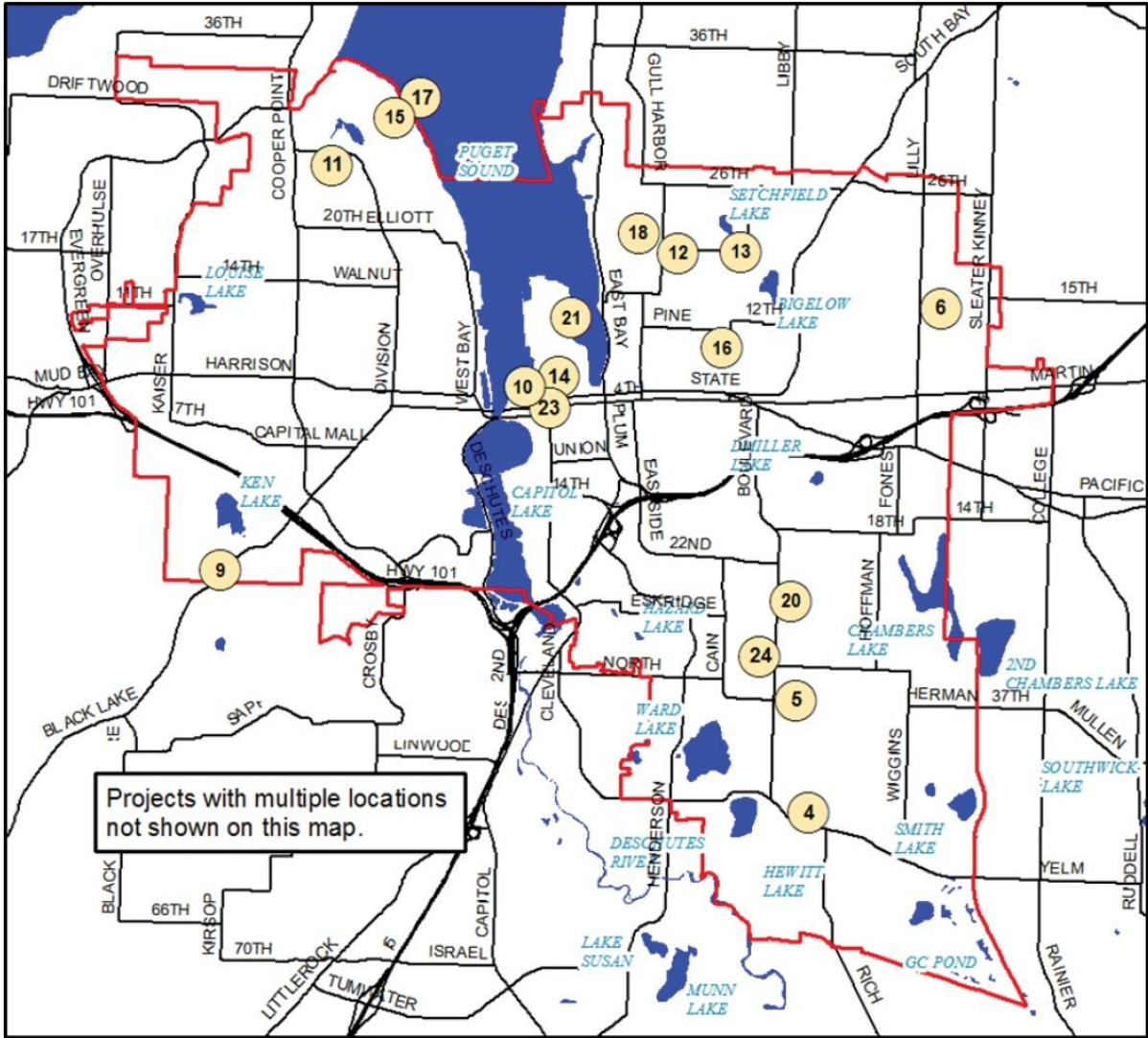

Table 10.5

Summary Table of Wastewater Projects for 2014 - 2023

Projects amounts are in 2013 dollars

Program Number, Name & Project	2014	2015	2016	2017	2018	2019	2020	2021	2022	2023
9021 - Asphalt Overlays										
Asphalt Overlay	10,500	10,500	10,500	10,500	10,500	10,500	10,500	10,500	10,500	10,500
9703 - Replacements and Repairs										
Prioritized Repairs	265,000	265,000	265,000	265,000	265,000	265,000	265,000	265,000	265,000	265,000
Spot Repairs	100,000	100,000	100,000	100,000	100,000	100,000	100,000	100,000	100,000	100,000
Manhole Repair and Replacement		100,000			100,000			100,000		
Commercial STEP Conversion on Yelm Highway		420,000								
Pipe Corrosion Abatement, Phase 1	150,000									
Pipe Corrosion Abatement, Phase 2			150,000							
STEP Pump Replacement, Phase 1										
STEP Tank Replacement, Phase 2										
9806 - Lift Stations (20% design/engineering, 80% construction)										
Black Lake Lift Station Upgrade <i>(partially funded in 2017)</i>	1,100,000									
Water Street Generator		150,000								
28th Ave. NW Lift Station Property Acquisition		100,000								
Miller and Central Lift Station Upgrade			750,000							
Miller and Ann Generator				60,000						
Water St Lift Station Force Mains Upgrade					900,000					
Old Port 2 Lift Station Upgrade						600,000				
Roosevelt and Yew LS Upgrade								600,000		
Old Port 1 Lift Station Upgrade									600,000	
Jasper Lift Station Upgrade										130,000
AC Force Main Upgrades, Phase 1										
Rossmoor Lift Station Upgrade										
East Bay Marina Lift Station Upgrade										
AC Force Main Upgrades, Phase 2										
Water Street Lift Station Upgrade										
9808 - Sewer System Planning										
Sewer System Televising and Condition Rating Program	21,000	21,000	21,000	21,000	21,000	21,000	21,000	21,000	21,000	21,000
9809 - Sewer System Extensions										
Boulevard Sewer Extension at Morse Merryman RAB				750,000						750,000
Future Sewer Extension at Roundabout TBD										
9810 - Pipe Capacity Upgrades										
None										
9813 - Onsite Sewage System Conversions										
Annual Sewer Extensions	150,000	150,000	150,000	150,000	150,000	150,000	150,000	150,000	150,000	150,000
Neighborhood Sewer Program	500,000			500,000			500,000			500,000
9903 - Infrastructure Pre-Design										
Pre-Design	37,200	37,200	37,200	37,200	37,200	37,200	37,200	37,200	37,200	37,200

Total for Each Year = \$2,333,700 \$1,353,700 \$1,483,700 \$1,893,700 \$1,893,700 \$1,583,700 \$1,183,700 \$1,083,700 \$1,283,700 \$1,183,700 \$1,963,700

Table 10.6

Summary Table of Wastewater Projects for 2024 - 2033

Projects amounts are in 2013 dollars

Program Number, Name & Project	2024	2025	2026	2027	2028	2029	2030	2031	2032	2033	Totals	Program Subtotals
9021 - Asphalt Overlays												
Asphalt Overlay	10,500	10,500	10,500	10,500	10,500	10,500	10,500	10,500	10,500	10,500	210,000	210,000
9703 - Replacements and Repairs												
Prioritized Repairs	265,000	265,000	265,000	265,000	265,000	265,000	265,000	265,000	265,000	265,000	5,300,000	5,300,000
Spot Repairs	100,000	100,000	100,000	100,000	100,000	100,000	100,000	100,000	100,000	100,000	2,000,000	2,000,000
Manhole Repair and Replacement	100,000			100,000						100,000	700,000	700,000
Commercial STEP Conversion on Yelm Highway											420,000	420,000
Pipe Corrosion Abatement, Phase 1											150,000	150,000
Pipe Corrosion Abatement, Phase 2		300,000									150,000	150,000
STEP Pump Replacement, Phase 1											300,000	300,000
STEP Tank Replacement, Phase 2						1,500,000					1,500,000	1,500,000
9806 - Lift Stations												
Black Lake Lift Station Upgrade (partially funded in 2011)											1,100,000	1,100,000
Water Street Generator											150,000	150,000
28th Ave. NW Lift Station Property Acquisition											100,000	100,000
Miller and Central Lift Station Upgrade											750,000	750,000
Miller and Ann Generator											60,000	60,000
Water St Lift Station Force Mains Upgrade											900,000	900,000
Old Port 2 Lift Station Upgrade											600,000	600,000
Roosevelt and Yew LS Upgrade											600,000	600,000
Old Port 1 Lift Station Upgrade											600,000	600,000
Jasper Lift Station Upgrade											130,000	130,000
AC Force Main Upgrades, Phase 1	900,000										900,000	900,000
Rossmoor Lift Station Upgrade		500,000									500,000	500,000
East Bay Marina Lift Station Upgrade				750,000							750,000	750,000
AC Force Main Upgrades, Phase 2											900,000	900,000
Water Street Lift Station Upgrade						900,000					900,000	900,000
9808 - Sewer System Planning												
Sewer System Televising and Condition Rating Program	21,000	21,000	21,000	21,000	21,000	21,000	21,000	21,000	21,000	21,000	420,000	420,000
9808 - Sewer System Planning												
Sewer System Planning											1,500,000	1,500,000
Boulevard Sewer Extension at Morse Merryman RAB				750,000							1,500,000	1,500,000
Future Sewer Extension at Roundabout TBD											1,500,000	1,500,000
9810 - Pipe Capacity Upgrades												
None											0	0
9813 - Onsite Sewage System Conversions												
Annual Sewer Extensions	150,000	150,000	150,000	150,000	150,000	150,000	150,000	150,000	150,000	150,000	3,000,000	3,000,000
Neighborhood Sewer Program											3,500,000	3,500,000
9903 - Infrastructure Pre-Design												
Pre-Design	37,200	37,200	37,200	37,200	37,200	37,200	37,200	37,200	37,200	37,200	744,000	744,000
Totals												
Check sum=												
Total for Each Year =	\$ 1,583,700	\$ 1,383,700	\$ 1,083,700	\$ 2,183,700	\$ 583,700	\$ 2,793,700	\$ 2,783,700	\$ 2,583,700	\$ 3,083,700	\$ 683,700	\$ 34,034,000	\$ 34,034,000



Paying for the Plan

Chapter 11

This chapter describes the current finances of the Utility as well as summarizes the financial policies and funding needed to implement the Plan. The detailed financial report by the City's financial consultant, Financial Consulting Solutions Group (FCSG), is presented in Appendix K.

The Wastewater Utility finances the infrastructure improvements and planning and program implementation services described in the Plan. Finances are managed separately for operations and capital improvements. Most revenue is from monthly rates charged to customers and general facilities charges (GFCs) charged for new sewer connections.

11.1 Revenue and Expenses

Revenue primarily comes from monthly rates and is used to fund staffing and administrative expenses, capital projects, taxes, and depreciation and amortization of capital assets. Rate revenue has increased from \$10.96 million in 2005 to a projected \$16.28 million in 2013. About two-thirds of this revenue is the rate charged by the LOTT Clean Water Alliance for wastewater treatment services and collected by the City through monthly charges (projected to be \$10.49 million in 2013). GFCs supplement the capital budget.

Figure 11.1 illustrates the amounts generated from Utility rates and GFCs in 2012, excluding revenues collected for LOTT.

For the 2012 Wastewater Utility budget, approximately 38 percent of the Utility's costs were attributable to capital projects and debt-service; the remaining 62 percent supported operations and administration expenses (see also Section 11.6 and Figure 11.2 below). The City's six-year Capital Facilities Plan (CFP) is updated each year by City Council. The CFP includes the capital projects identified in Chapter 10.

11.2 Assets and Liabilities

The Wastewater Utility maintains a balance sheet of current and long-term assets and liabilities. Between 2005 and 2012, total assets increased from \$28.05 million to \$49.55 million. Current and long-term liabilities increased from \$0.70 million to \$9.06 million. As of 2012, the City's long-term debt was \$7,775,406 from two bonds, a Public Works Trust Fund loan, and a State Revolving Fund loan.

The City's financial consultant, FCSG, reports that the Utility has generally realized positive net income and annual increases in net asset value over the past few years, exhibiting relatively stable financial performance. The Utility displays a strong, high quality balance sheet, with long-term debt as a percent of assets increasing from 1.3% to 13.2% over the comparative

period. As it is common for municipal utilities to have outstanding debt equal to 15% - 35% of the booked cost of fixed assets, the Utility still has significant long-term borrowing capacity that might be used to finance future capital improvements if and when needed and appropriate.

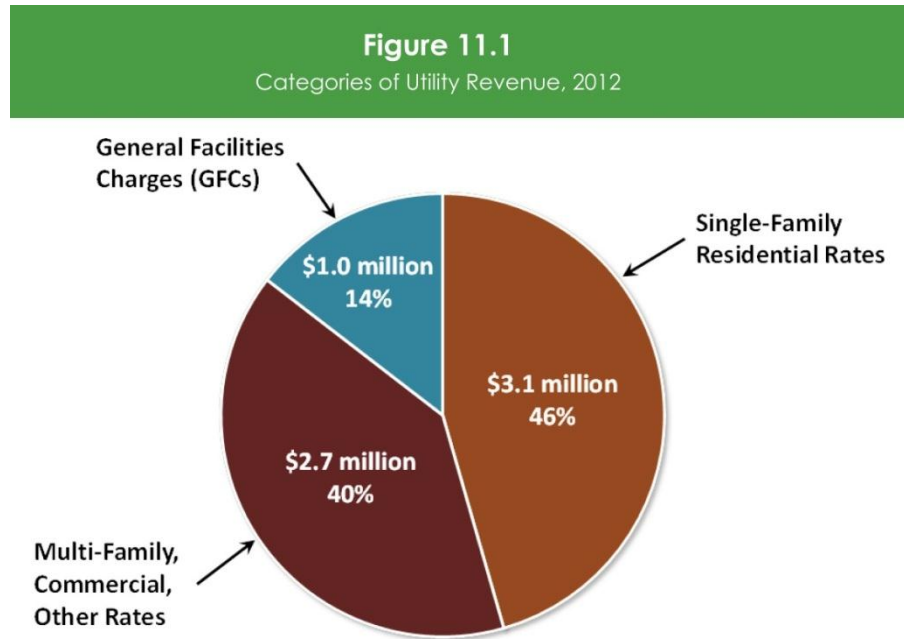

11.3 Rates and Rate Structure

The Utility currently has about 15,918 single and multi-family residential accounts (about 60% are single family residential) and 1,563 commercial and public sector accounts. The Utility's rate structure for all customers is based on equivalent residential units (ERUs). The ERU is based on the wastewater generated from residential and commercial sources. See section 2.3, Wastewater Flows, in Chapter 2 for an explanation of how the ERU is calculated.

A rate increase of 5 percent (\$0.58/month per ERU) in 2006 helped fund improved program management capability. The 2013 Wastewater Utility rate is \$18.54 per ERU per month. Gravity sewer, STEP system and community onsite system customers pay the same monthly rate. In addition, the City collects monthly rates of \$33.99 per ERU, which is paid to the LOTT Clean Water Alliance for wastewater treatment services.

The Utility also collects general facility charges (GFCs) from new developments. These charges are one-time fees that recover a proportionate share of the costs associated with existing and planned Utility infrastructure from newcomers to the City's wastewater system. Its purpose is to promote equity between existing and future customers. The GFC establishes a pro rata share of capitalized system costs attributable to new development, and imposes that cost as a condition of service. While revenue generated by GFCs varies appreciably from year to year, annual revenues averaged approximately \$793,000 over the past five years.

11.4 Financial Policies

As an enterprise fund, the Utility is fully self-sufficient, relying solely on its own revenues for financial viability. The consultant's analysis of the Utility's ability to fund the Plan is based on a set of fiscal policies that define the City's minimum financial criteria. These fiscal policies relate to cash management, capital funding strategy, financial performance and rate equity.

Cash Management

The City's policy is to maintain working capital and other reserves consistent with possible fluctuation in revenues and expenditures. Historically, the Wastewater Utility's standard is to maintain a minimum operating fund balance equal to 10 percent of annual operating expenses (excluding payments to LOTT as a "pass-through" of revenue derived from LOTT's monthly rate). In addition, a capital contingency reserve equal to 5 percent of active capital appropriations is maintained in case of capital cost overruns or acceleration of capital expenditures.

It is worth noting that the anticipated change to volume-based rates for residential customers will increase the volatility of Utility revenues. This volatility is limited by the fact that the proposed structure is a tiered flat-rate structure based on water usage - the primary revenue risk is that customers that are near the usage threshold of a defined tier would use less water and fall into a lower rate tier. The financial analysis prepared by FCSG suggests that the existing operating fund balance will be adequate to cover some fluctuation in revenue levels over the next several years. Depending on the revenue impacts that the Utility experiences following the implementation of the volume-based structure, it may wish to consider increasing its minimum reserve balances to address future volatility.

Capital Funding Strategy

The City has two basic policies to provide ongoing capital funding resources:

- To require an equitable financial contribution from all new development; this requirement is met through the GFC. GFC revenues are used first to pay current Utility debt service payments, and second as a source of cash funding for future capital projects.
- To require existing ratepayers to support the City's full cost of providing service, including annual depreciation expense on Utility assets. Though depreciation is not a cash expense per se, the City uses depreciation expense as a basis for funding capital re-investment in the system. To avoid charging customers for the future replacement of assets that they are concurrently paying for through the debt service component of rates, the City's capital re-investment policy determines annual funding levels by deducting current debt principal payments from depreciation expense in the useful life of the infrastructure. This approach does not ensure full cash funding of system replacements, but is a common way to equitably charge current customers for use and decline of the system. It provides a major source of capital re-investment, which can be augmented with use of debt financing.

Financial Performance

These policies include the requirement to maintain a balanced budget, to meet minimum reserve requirements and to set rates to ensure payment of annual debt service for revenue bonds.

11.5 Paying for the Plan

Implementation of the Plan will decrease the average annual CFP funding from approximately \$4.5 million to \$1.5 million. Capital expenditures will total \$9.0 million between 2014 and 2019. Debt financing of a portion of these costs is not anticipated.

The financial analysis established a hierarchy of capital funding:

- First using available cash and investment resources; existing capital fund balances are used to directly fund project costs.
- Second, use utility equity resources - ongoing revenue from GFCs to directly fund project costs.

The following rates will fund Plan implementation:

- Monthly City Wastewater Utility Rates: Annual rate revenue increases of 4 percent from 2014 - 2016, and 3 percent from 2017 - 2018. Two volume-based rate structure alternatives have been developed for consideration in 2014:

Table 11.1

Potential Wastewater Utility Rates with Tiered Structure

Alternative A	2013	2014	2015	2016	2017	2018
Tier 1 (0 – 2 ccf per Month)	\$18.54	\$13.06	\$13.58	\$14.13	\$14.55	\$14.99
Tier 2 (> 2 ccf per Month)	\$18.54	\$19.59	\$20.37	\$21.19	\$21.82	\$22.48
Alternative B	2013	2014	2015	2016	2017	2018
Tier 1 (0 – 2 ccf per Month)	\$18.54	\$13.53	\$14.07	\$14.63	\$15.07	\$15.53
Tier 2 (2 – 4 ccf per Month)	\$18.54	\$17.65	\$18.36	\$19.09	\$19.66	\$20.25
Tier 3 (> 4 ccf per Month)	\$18.54	\$20.29	\$21.10	\$21.95	\$22.60	\$23.28

- Customers using 2 ccf or less per month (about 18% of the total single-family customer base) will actually see a reduction in their monthly bill under both alternatives. Depending on the alternative, their bill will decrease by \$3.01 - \$3.55 (16 - 19 percent) by 2018.
- Customers that use more than 2 ccf but not more than 4 ccf per month (about 25% of the total single-family customer base) will see a cumulative increase of \$3.94 (21 percent) in their monthly bill under Alternative A, averaging \$0.79 (4 percent) per year through 2018.

Under Alternative B, these customers will see a cumulative increase of \$1.71 (9 percent) in their monthly bill by 2018, which averages to an increase of \$0.34 (2 percent) per year.

- Customers that use more than 4 ccf per month (about 57% of the total single-family customer base) will see an increase under both alternatives. Depending on the alternative, their bill will increase by \$3.94 - \$4.74 (21 - 26 percent) by 2018, which averages to \$0.79 - \$0.95 (4 - 5 percent) per year during the planning period.
- Considering LOTT charges (which are expected to increase with inflation on the order of 2 - 3 percent per year), customers using 2 ccf or less will see an increase of less than 0.5 percent in their total wastewater bill by 2018; other customers will see an increase averaging 2 - 3 percent per year.
- Increased GFC. An increase of 4.5 percent from \$3,198.51 to \$3,342.00 per ERU, to reflect the current pro rata share of system costs.

11.6 Comparison of LOTT and Olympia's Cost Centers

Implementation of the Plan is reflected in three cost centers: (1) net operating expense, (2) debt service (bonds and loans), and (3) capital facilities plan expense. Figure 11.2 shows this cost breakdown for each entity, for the period 2013-2018.

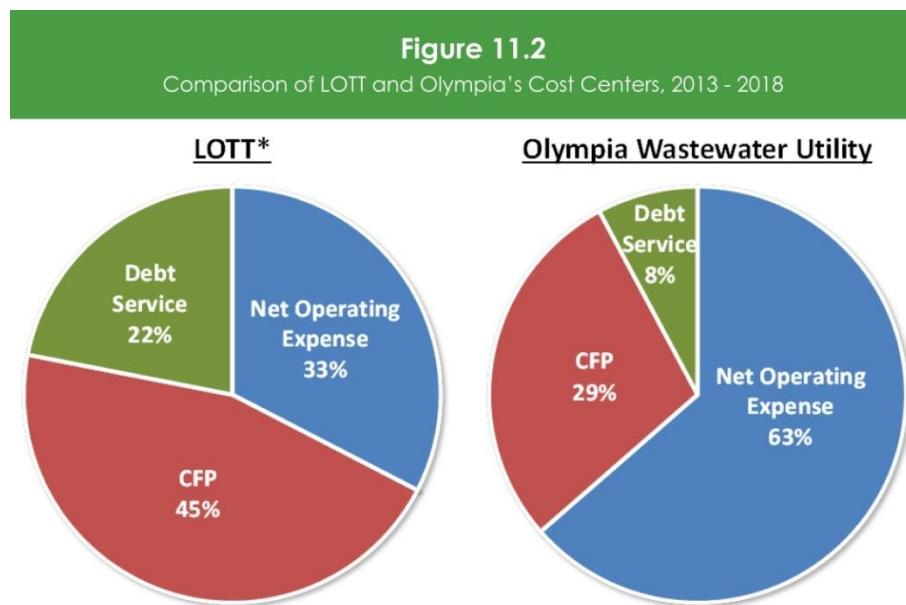

*Source: LOTT's 2013 Budget and Capital Improvement Plan, November 14, 2012.

The pie charts in Figure 11.2 indicate that LOTT's budget is capital project-intensive, while the City's Wastewater Utility budget is operations and maintenance-intensive. LOTT is responsible for funding the network of infrastructure that comprises the regional treatment and transmission system. The City's Wastewater Utility, by contrast, is relatively smaller in scale and funds a variety of annual operating costs including taxes, interfund transfers, and City overhead in addition to more labor-intensive functions such as field work and customer service.